

HIGHWAY CONSTRUCTION DETAILS 700 SERIES

VOLUME 1 GENERAL DETAILS



TRANSPORT & HIGHWAYS

ISSUE 3

FEBRUARY 2013

PRODUCED BY
DESIGN SERVICES
COMMUNITIES
SHIRE HALL
WARWICK
CV34 4RL

**HIGHWAY CONSTRUCTION DETAILS: 700 SERIES
VOLUME 1: GENERAL DETAILS**

CONTENTS

| NOTES FOR GUIDANCE | | |
|---------------------------------|--|---------------|
| | Description | Issued |
| | NOTES FOR GUIDANCE | MAY. 2010 |
| | NOTES FOR GUIDANCE ANNEX 1 | MAY. 2010 |
| HIGHWAY CROSS SECTIONS | | |
| Number | Description | Issued |
| A 701.1 | CUTTING & EMBANKMENT: SINGLE CARRIAGEWAY | MAY. 2010 |
| A 701.2 | CUTTING & EMBANKMENT: DUAL CARRIAGEWAY | MAY. 2010 |
| EDGE OF PAVEMENT DETAILS | | |
| Number | Description | Issued |
| B 701.1 | CARRIAGEWAYS WITH CONCRETE KERBING | MAY. 2010 |
| B 701.2 | CARRIAGEWAYS WITHOUT CONCRETE KERBING | MAY. 2010 |
| B 701.3 | PAVING ON ROUNDABOUT ISLANDS | OCT. 2010 |
| B 702.1 | KERBS, EDGING & CHANNELS | MAY. 2010 |
| B 703.1 | PRECAST CONCRETE COMBINED DRAINAGE & KERB BLOCKS: TYPICAL CROSS SECTIONS | MAY. 2010 |
| B 703.2 | PRECAST CONCRETE COMBINED DRAINAGE & KERB BLOCKS: LOW POINT END STOP & OUTFALL DETAILS | OCT. 2010 |
| B 703.3 | PRECAST CONCRETE COMBINED DRAINAGE & KERB BLOCKS: MISCELLANEOUS ITEMS | MAY. 2010 |
| B 704.1 | FOOTWAY & CYCLEWAY CONSTRUCTION | FEB. 2013 |
| B 704.2 | ACCESS CONSTRUCTION | OCT. 2010 |
| B 704.3 | BLOCK PAVING | MAY. 2010 |
| B 704.4 | BUS BOARDING POINT (QUALITY BUS CORRIDOR) WITH KASSEL KERBS | MAY. 2010 |
| B 705.1 | STRIP WIDENING & LONGITUDINAL JOINTING DETAILS | MAY. 2010 |
| B 705.2 | OVERLAY & TRANSVERSE JOINTING DETAILS | OCT. 2010 |
| DRAINAGE | | |
| Number | Description | Issued |
| F 701.1 | SURFACE WATER DRAINS: BEDDING & TRENCH DETAILS | MAY. 2010 |
| F 702.1 | FILTER DRAINS: BEDDING & TRENCH DETAILS SHEET 1 | MAY. 2010 |
| F 702.2 | FILTER DRAINS: BEDDING & TRENCH DETAILS SHEET 2 | MAY. 2010 |
| F 703.1 | PRECAST CONCRETE CATCHPITS: TYPES 71 & 72 | OCT. 2010 |
| F 703.2 | BRICK CATCHPIT: TYPE 73 | MAY. 2010 |
| F 704.1 | GULLIES: TYPES 1, 2A & 2B | MAY. 2010 |
| F 704.2 | GULLY CONNECTIONS & RODDING EYES | MAY. 2010 |
| F 705.1 | HEADWALLS: TYPES 1, 2 & 3 | MAY. 2010 |
| F 705.2 | HEADWALLS: TYPES 4 & 5 & DITCH LINING DETAIL | MAY. 2010 |
| F 706.1 | CONNECTION OF PERMANENTLY SEVERED LAND DRAINS | MAY. 2010 |
| F 707.1 | CONCRETE PIPE SADDLES | MAY. 2010 |

| FENCES, STILES AND GATES | | |
|---------------------------------|---|---------------|
| Number | Description | Issued |
| H 701.1 | BOUNDARY HEDGE | MAY. 2010 |
| H 702.1 | FENCING: TIMBER POST & RAIL | MAY. 2010 |
| H 703.1 | TIMBER FIELD GATES: TYPES 1, 2 & 3 | MAY. 2010 |
| UNDERGROUND CABLE DUCTS | | |
| Number | Description | Issued |
| I 701.1 | NEW SERVICE DUCTS & PROTECTION OF EXISTING SERVICES | MAY. 2010 |
| I 702.1 | JUNCTION BOX FOR SERVICE DUCTS | MAY. 2010 |
| MISCELLANEOUS | | |
| Number | Description | Issued |
| K 701.1 | TRENCH REINSTATEMENT IN CARRIAGEWAYS & PAVED AREAS | MAY. 2010 |
| K 702.1 | PEDESTRIAN GUARDRAILS | MAY. 2010 |
| K 703.1 | STANDARD ILLUMINATED REFUGE & PEDESTRIAN REFUGE | OCT. 2010 |
| K 703.2 | REFUGE & PEDESTRIAN REFUGE WITH FLEXIBLE SIGNAGE | OCT. 2010 |
| K 703.3 | REFUGE & PEDESTRIAN REFUGE WITH FLEXIBLE SIGNAGE & SOLAR POWERED SIGN | OCT. 2010 |
| K 703.4 | REFUGE & PEDESTRIAN REFUGE WITH FLEXIBLE SIGNAGE & BEACON | OCT. 2010 |
| K 703.5 | REFUGE DETAIL WITH NAL SOCKET | MAY. 2010 |
| K 703.6 | SOLAR AND UNLIT BOLLARDS | MAY. 2010 |
| K 703.7 | ILLUMINATED BOLLARDS MAINS POWERED | |
| K 704.1 | TRAFFIC SIGNS: FABRICATION & MOUNTING DETAILS | MAY. 2010 |
| K 705.1 | SIGN BOARD DETAILS: TYPES 1, 2, 3 & 4 | MAY. 2010 |
| K 705.2 | SIGN BOARD DETAILS: TYPE 5 | MAY. 2010 |
| K 706.1 | TRAFFIC SIGNAL CONTROLLER CABINET | MAY. 2010 |

**HIGHWAY CONSTRUCTION DETAILS: 700 SERIES
VOLUME 1: GENERAL DETAILS**

NOTES FOR GUIDANCE

| INTRODUCTION | |
|---------------------|--|
| GENERAL | |
| 1. | These notes apply to all Design Offices preparing schemes for Warwickshire County Council. They refer to the Highway Construction Details: 700 Series (HCD 700s) listed on the preceding contents page. |
| 2. | Designers shall use the HCD 700s instead of any similarly titled drawings or details issued by the Highways Agency (HA). The HA's Highway Construction Details (HCDs) are contained in the Manual of Contract Documents for Highway Works: Volume 3. |
| 3. | The HA's HCDs have generally been prepared for use on Motorways and Trunk Roads. Experience has shown that for County Roads there is a need to: <ul style="list-style-type: none"> 3.1 modify some of the HCDs to suit local conditions; and 3.2 produce details where none exist. <p>The HCD 700s and associated Notes for Guidance reflect these needs.</p> |
| 4. | In some cases, the Notes for Guidance listed below refer to numbered appendices such as Appendix 5/1. These numbered appendices relate to those included in the modified and extended Specification, which forms part of the County Council's standard contract document for highway construction works. |
| 5. | Companies tendering for County Council construction contracts will be issued with either the complete set of HCD 700s, or a set of those HCD 700 details that are relevant to the particular contract. All relevant HCD 700s will be listed in Appendix 0/4 of the modified and extended Specification. |
| 6. | From time to time, the HCD 700s and associated Notes for Guidance may be updated. At such times, the issue date and issue status will be amended accordingly. |
| 7. | Complete volumes of the HCD 700s may be sent to contractors or developers in the form of paper copies. Once sent, these paper copies will become uncontrolled. County Council staff sending out such copies must make recipients aware that the HCD 700s may be updated and reissued periodically. Recipients must also be made aware that it is their responsibility to ensure that they are working to the most up-to-date issue. This principle does not apply where paper copies are despatched to tenderers as part of a set of contract documents. |
| 8. | Designers should note that the HCD 700s represent the preferred requirements of the County Council. Nevertheless, in certain circumstances, variations may be necessary. In such circumstances, the variations shall be made clear on either the scheme specific construction drawings or the numbered appendices of the modified and extended Specification. Neither the HCD 700s nor the HCDs shall be altered in any way. |

| | 9. | Designers wishing to apply any variation to the HCD 700s on County Council construction projects must first agree the variation with Transport for Warwickshire's Design Services. Designers proposing to apply the HCD 700s on construction projects where the County Council is not the client must first agree to do so with the client concerned. |
|---------------------------------|---|---|
| | 10. | Any comments, queries or suggestions for improvement relating to the HCD 700s should be addressed to: <p>The Group Managers Transport for Warwickshire Design Services Environment & Economy Directorate PO Box 43 Shire Hall Warwick CV34 4SX</p> |
| HIGHWAY CROSS SECTIONS | | |
| A 701.1 | CUTTING & EMBANKMENT: SINGLE CARRIAGEWAY | |
| | 1. | Refer to B 701.1 and B 701.2 for edge details. |
| | 2. | Lighting columns are usually positioned 2.0m back from the kerb face. This may be varied but if so, the new position must be stated in the contract documents. County Highways' Street Lighting section must approve in advance any variation to the usual position of lighting columns. |
| | 3. | Where possible, verges shall be 3.5m wide (or 4.5m wide where the provision of highway features and other services require it). Verges may be reduced to a width below 3.5m where circumstances necessitate it. In such cases the actual verge width shall be stated in the contract documents. |
| A 701.2 | CUTTING & EMBANKMENT: DUAL CARRIAGEWAY | |
| | 1. | Refer to the notes for A 701.1. |
| EDGE OF PAVEMENT DETAILS | | |
| B 701.1 | CARRIAGEWAYS WITH CONCRETE KERBING | |
| | 1. | Refer to F 702.1, F 702.2 and Appendix 5/1 for filter drain details. |
| B 701.2 | CARRIAGEWAYS WITHOUT CONCRETE KERBING | |
| | 1. | Refer to the notes for B 701.1. |
| B 701.3 | PAVING ON ROUNDABOUT ISLANDS | |
| | 1. | Kerb types shall be stated in the contract documents, either in a schedule or on the scheme specific drawings. |

| EDGE OF PAVEMENT DETAILS (cont'd) | | |
|--|---|--|
| B 702.1 | KERBS, EDGING & CHANNELS | |
| | 1. | Refer to the notes for B 701.3. |
| B 703.1 | PRECAST CONCRETE COMBINED DRAINAGE & KERB BLOCKS: TYPICAL CROSS SECTIONS | |
| | 1. | Schedules for precast concrete combined drainage and kerb blocks must be included in both Appendix 5/1 and Appendix 11/1. |
| B 704.2 | ACCESS CONSTRUCTION | |
| | 1. | Type 1 Access Construction is intended for residential use. Type 2 Access Construction is intended for industrial use. |
| B 704.3 | BLOCK PAVING | |
| | 1. | Block paving details shall be included in Appendix 11/1. |
| DRAINAGE | | |
| F 701.1 | SURFACE WATER DRAINS: BEDDING & TRENCH DETAILS | |
| | 1. | The details of permitted alternatives are shown in Notes for Guidance: Annex 1, Table 1. Generally, three types of pipe material (vitrified clay, concrete and certain approved polymer materials) are permitted. Only pipes manufactured from the polymer materials specified in S.H.W. Table 5/1 will be permitted, unless they hold a current British Board of Agrément Roads and Bridges Certificate (or equivalent) stating that they are a suitable alternative for the 'usage' specified in S.H.W. Table 5/1. |
| | 2. | Table 1 states the minimum cover requirement for each pipe group. Design engineers should examine the particular circumstances for each pipe length to determine whether or not the pipe group recommended by the table is appropriate. For example, if a pipe has a depth of cover less than 0.9m, but is located in soft ground so far from the carriageway that it is very unlikely to be trafficked; a concrete surround to the pipe may not be necessary. |
| | 3. | It should be noted that bedding (including laying and any pipe surround) comprises all operations up to an including 0.3m above the pipe soffit. Backfilling comprises all operations from this point up to ground level, formation level or sub-formation level, whichever applies. |
| | 4. | If sulphate-resisting cement needs to be used in any concrete pipe surround, it must be specified in Appendix 26/1. |
| | 5. | It should be noted that all pipes are designed for the final serviceable condition. Pipes are not designed to take into account loadings imposed by construction traffic. |

| | 6. | If surface water drains are to be adopted by the Sewer Authority, the specifications of that authority take precedence over the specifications provided in these details. |
|---------------------------------|---|--|
| | 7. | Bedding and trench details for the drains included in M.C.D. Vol. 3 have now been incorporated into this system. |
| F 702.0 F 702.1 | FILTER DRAINS: BEDDING & TRENCH DETAILS | |
| | 1. | The details of permitted alternatives are shown in Notes for Guidance: Annex 1, Table 2. Refer to the notes for F 701.1. |
| | 2. | Group F7 drains alone shall only be used to drain formation/sub-formation where there is either no embankment, or where there is an embankment, but its height is negligible. Group F7 drains must not be used for the purpose of controlling the water table level. Where there is an embankment of a significant height, Group F7 drains must be accompanied by a suitable filter drain at the foot of the embankment. |
| F 707.1 | CONCRETE PIPE SADDLES | |
| | 1. | If surface water drains are to be adopted by the Sewer Authority, the Authority's specification for pipe connections takes precedence over the specification provided in this detail. |
| FENCES, STILES AND GATES | | |
| H 701.1 | BOUNDARY HEDGE | |
| | 1. | Plant species in rural Warwickshire shall be chosen from those listed for hedges in that part of the county. The list of plant species can be found in the appropriate volume of 'Warwickshire Landscapes Guidelines'. |
| H 703.1 | TIMBER FIELD GATES: TYPES 1, 2 & 3 | |
| | 1. | Gates shall comply with the requirements of S.H.W. Series 300. Additional requirements shall be specified in Appendix 1/15 and/or Appendix 3/1. |
| UNDERGROUND CABLE DUCTS | | |
| I 701.1 | NEW SERVICE DUCTS & PROTECTION OF EXISTING SERVICES | |
| | 1. | The details of permitted duct alternatives are shown in Notes for Guidance: Annex 1, Table 3. Only two types of duct pipe material (vitrified clay and PVC-U) are permitted, and these shall comply with the requirements of S.H.W. Table 5/2. |
| MISCELLANEOUS | | |
| K 701.1 | TRENCH REINSTATEMENT IN CARRIAGEWAYS & PAVED AREAS | |
| | 1. | Permitted materials shall be stated in Appendix 7/1. Any alterations to the depths of construction shown, shall be stated in Appendix 7/2. |

| MISCELLANEOUS (cont'd) | | |
|-------------------------------|--|--|
| K 702.1 | PEDESTRIAN GUARDRAILS | |
| | 1. | Any special requirements shall be stated in Appendix 4/2. |
| | 2. | High visibility pedestrian guardrail panels shall be provided at pedestrian crossing points. |
| K 703.1 | STANDARD ILLUMINATED REFUGE & PEDESTRIAN REFUGE | |
| | 1. | Lighting details, including electrical work shall be stated in Appendix 14/2 and Appendix 14/4. There are three alternatives to the Standard Illuminated Refuge & Pedestrian Refuge, which are shown on details K 703.2, K 703.3 and K703.4. Wherever a refuge is required, designers should seek advice from the Environment & Economy Directorate's Traffic Group on which refuge detail to specify. |

**HIGHWAY CONSTRUCTION DETAILS: 700 SERIES
VOLUME 1: GENERAL DETAILS**

NOTES FOR GUIDANCE ANNEX 1

TABLE 1: SPECIFICATION FOR SURFACE WATER DRAINS

| PIPE GROUP | DEPTH OF COVER | PIPE MATERIAL | | | | | |
|------------------|----------------|------------------|-------------------------|---------------|-------------------------|---------------------------|-------------------------|
| | | VITRIFIED CLAY | | CONCRETE | | APPROVED POLYMER MATERIAL | |
| | | PIPE STANDARD | BEDDING & TRENCH DETAIL | PIPE STANDARD | BEDDING & TRENCH DETAIL | PIPE STANDARD | BEDDING & TRENCH DETAIL |
| S2 | 0.6m - 0.9m | refer to note 1. | Z | L | Z | refer to note 2. | Y |
| S3 | 0.9m – 5.0m | refer to note 1. | S | M | S | refer to note 2. | S |
| S7 (below c/way) | 0.6m - 0.9m | refer to note 1. | Z1 | M | Z1 | refer to note 2. | Y1 |
| S8 (below c/way) | 0.9m – 5.0m | refer to note 1. | S1 | M | S1 | refer to note 2. | S1 |

TABLE 2: SPECIFICATION FOR FILTER DRAINS

| PIPE GROUP | DEPTH OF COVER | PIPE MATERIAL | | | | | |
|------------|------------------|----------------|-------------------------|----------------|-------------------------|---------------------------|-------------------------|
| | | VITRIFIED CLAY | | CONCRETE | | APPROVED POLYMER MATERIAL | |
| | | PIPE STANDARD | BEDDING & TRENCH DETAIL | PIPE STANDARD | BEDDING & TRENCH DETAIL | PIPE STANDARD | BEDDING & TRENCH DETAIL |
| F2 | 0.9m – 2.0m | ES | G | L | G | refer to note 2. | J |
| F3 | 0.9m – 2.0m | ES | L | L | L | refer to note 2. | L |
| F4 | 0.9m – 2.0m | ES | H1 | L | H1 | refer to note 2. | I |
| F5 | 0.9m – 2.0m | ES | M | L | M | refer to note 2. | M |
| F6 | 0.9m – 2.0m | ES | K | L | K | refer to note 2. | K |
| F7 | refer to note 3. | not applicable | not applicable | not applicable | not applicable | refer to note 2. | not applicable |
| F8 | refer to note 3. | ES | Q | L | Q | refer to note 2. | Q |
| F9A | 0.6m | not applicable | not applicable | not applicable | not applicable | refer to note 2. | not applicable |
| F9B | 0.6m | not applicable | not applicable | not applicable | not applicable | refer to note 2. | not applicable |

NOTES

| | |
|----|---|
| 1. | Where the nominal diameter (DN) = 150mm, the pipe crushing strength shall be 22KN/m. Where DN ≥ 225mm, the pipe standard shall be Class 120. |
| 2. | Approved polymer materials shall be those listed in S.H.W. Table 5/1. Alternative polymer materials may be permitted, provided that they hold a current British Board of Agrément Roads and Bridges Certificate (or equivalent) stating that they are a suitable alternative for the 'usage' specified in S.H.W. Table 5/1. |
| 3. | The depth of cover on Group F7 drains shall be 0.3m plus the thickness of lower sub-base layer if specified. The depth of cover on Group F8 drains shall be 0.6m, or the external pipe diameter + 0.05m + the thickness of lower sub-base layer (if specified), whichever is the greater. |
| 4. | Where PVC-U (ultra-rib twin wall) pipes are to be used, the short-term ring stiffness shall be ≥ 8.0KN/m ² . The fifty-year stiffness shall be ≥ 3.0KN/m ² . |

**HIGHWAY CONSTRUCTION DETAILS: 700 SERIES
VOLUME 1: GENERAL DETAILS**

NOTES FOR GUIDANCE ANNEX 1

TABLE 3: SPECIFICATION FOR NEW SERVICE DUCTS

| DUCT GROUP | DEPTH OF COVER | DUCT PIPE MATERIAL | | | |
|------------|--------------------------|--------------------|-------------------------|--------------------|-------------------------|
| | | VITRIFIED CLAY | | PVC-U | |
| | | DUCT PIPE STANDARD | BEDDING & TRENCH DETAIL | DUCT PIPE STANDARD | BEDDING & TRENCH DETAIL |
| D1 | 0.90m min. (below c/way) | ES | D1 | refer to note 1. | D1 |
| D2 | 0.75m min. (below verge) | ES | D2 | refer to note 1. | D2 |

NOTES

1. The duct pipe standard for PVC-U duct pipes shall be in accordance with S.H.W. Table 5/2.

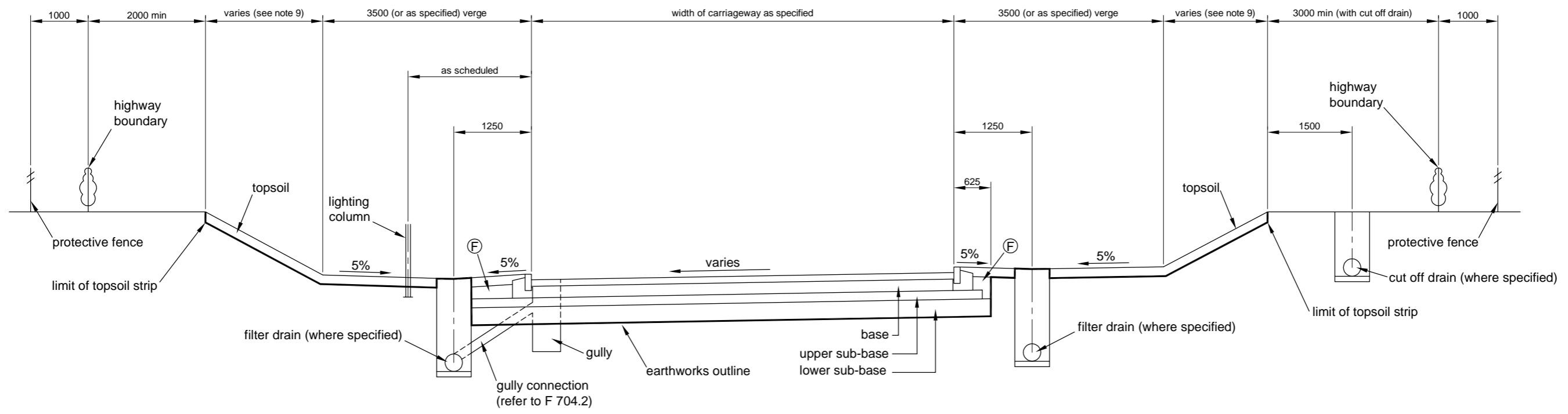

TYPICAL SECTION - CUTTING

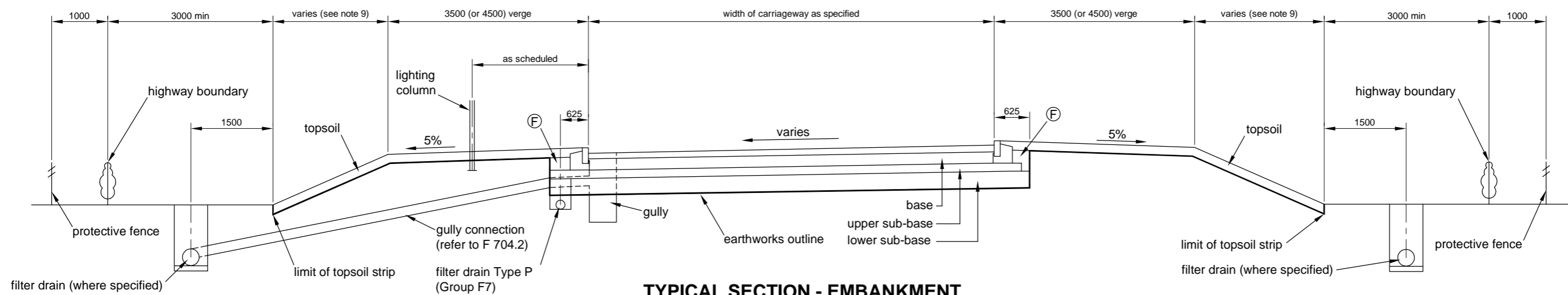

TYPICAL SECTION - EMBANKMENT

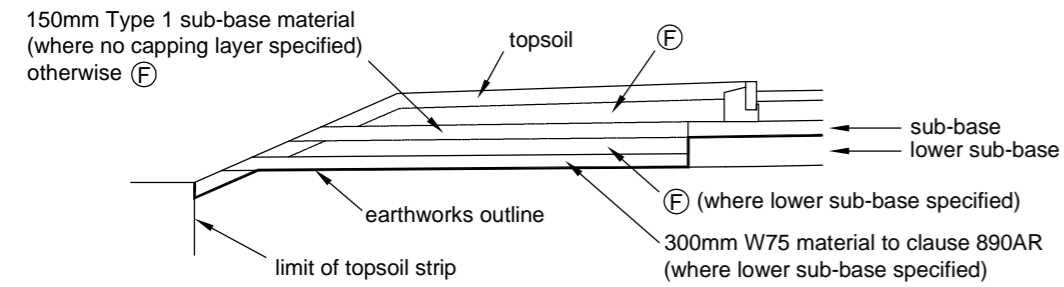

DETAIL WITHOUT FILTER DRAIN

NOTES

1. All dimensions are in millimetres unless stated otherwise.
2. Any scheme specific cross section layouts shall take precedence over this detail.
3. On balanced carriageways, the edge detail shall be the same on both sides and match the detail for the low side of carriageway. Refer to B 701.1 for edge details.
4. Depth of topsoil shall be 150mm unless stated otherwise.
5. Verges may be widened to 4.5m to accommodate footways. Refer to B 704.1 for footway details.
6. F = Fill material on sub-base material and base.
7. The position of lighting columns may vary where footways are required.
8. Refer to F 702.1 and F 702.2 for filter drain details.
9. Cutting and embankment slopes shall be 1:2 unless otherwise specified on scheme specific drawings.
10. Lower sub-base is W75 or W150 sub-base to clause 890AR.



HIGHWAY CONSTRUCTION DETAILS

TITLE 1
HIGHWAY CROSS SECTIONS

TITLE 2
CUTTING & EMBANKMENT: SINGLE CARRIAGEWAY

| | | | | |
|-----------------|----------|---|-------------------------------------|---------------------|
| PREVIOUS ISSUES | | ALL DIMENSIONS IN MILLIMETRES UNLESS STATED OTHERWISE | ORIGINAL DRAWING SIZE 420mm x 297mm | |
| ISSUE | DATE | | DRN | RJB |
| 1 | FEB 2005 | NOT TO SCALE | | CHKD CS |
| | | DRG NO. | A 701.1 | ISSUE STATUS 2 |
| | | | | ISSUE DATE MAY 2010 |

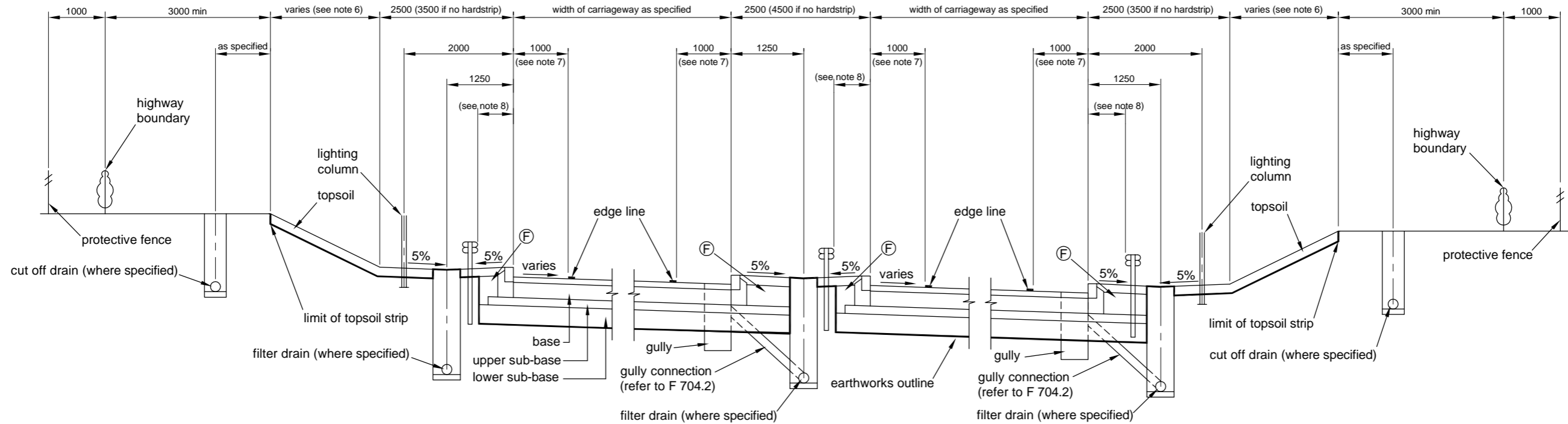

TYPICAL SECTION - CUTTING

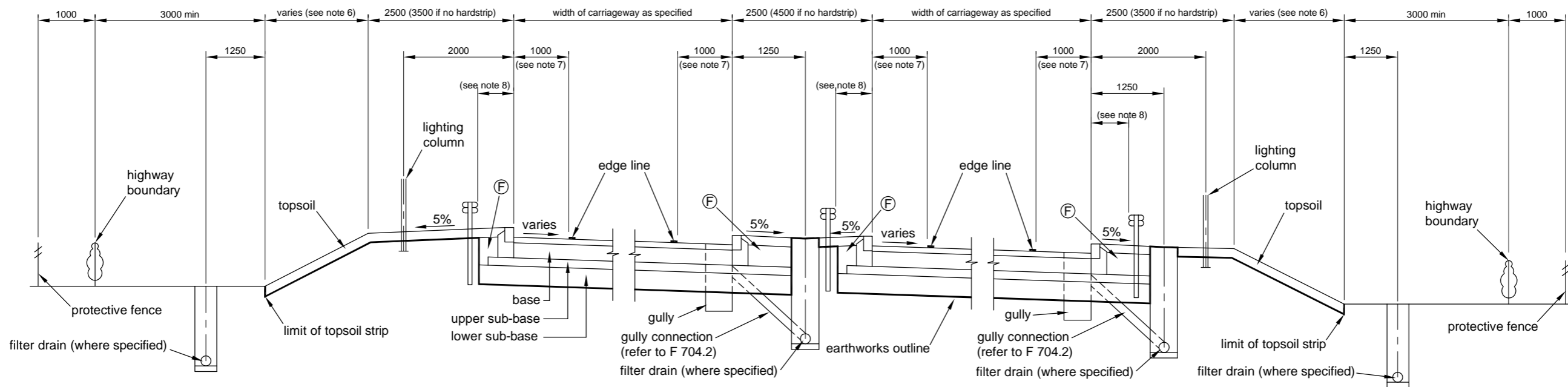

TYPICAL SECTION - EMBANKMENT

NOTES

1. All dimensions are in millimetres unless stated otherwise.
2. On balanced carriageways, the edge detail shall be the same on both sides and match the detail for the low side of carriageway. Refer to B 701.1 for edge details.
3. Depth of topsoil shall be 150mm unless stated otherwise.
4. (F) = Fill material on sub-base material and base.
5. Refer to F 702.1 and F 702.2 for filter drain details.
6. Cutting and embankment slopes shall be 1:2 unless otherwise specified on scheme specific drawings.
7. The 1000mm hardstrip dimension shall be measured from the edge of carriageway (kerb face) to the carriageway-side edge of the edge line.
8. Dimension as specified on the road restraint system HCDs.
9. Lower sub-base is W75 or W150 sub-base to clause 890AR.



**HIGHWAY
CONSTRUCTION
DETAILS**

TITLE 1
HIGHWAY CROSS SECTIONS

TITLE 2
**CUTTING & EMBANKMENT:
DUAL CARRIAGEWAY**

| PREVIOUS ISSUES | | ALL DIMENSIONS IN MILLIMETRES UNLESS STATED OTHERWISE | ORIGINAL DRAWING SIZE 420mm x 297mm | |
|-----------------|----------|---|-------------------------------------|------|
| ISSUE | DATE | | DRN | CHKD |
| 1 | FEB 2005 | NOT TO SCALE | RJB | CS |
| DRG NO. A 701.2 | | ISSUE STATUS 2 | ISSUE DATE MAY 2010 | |

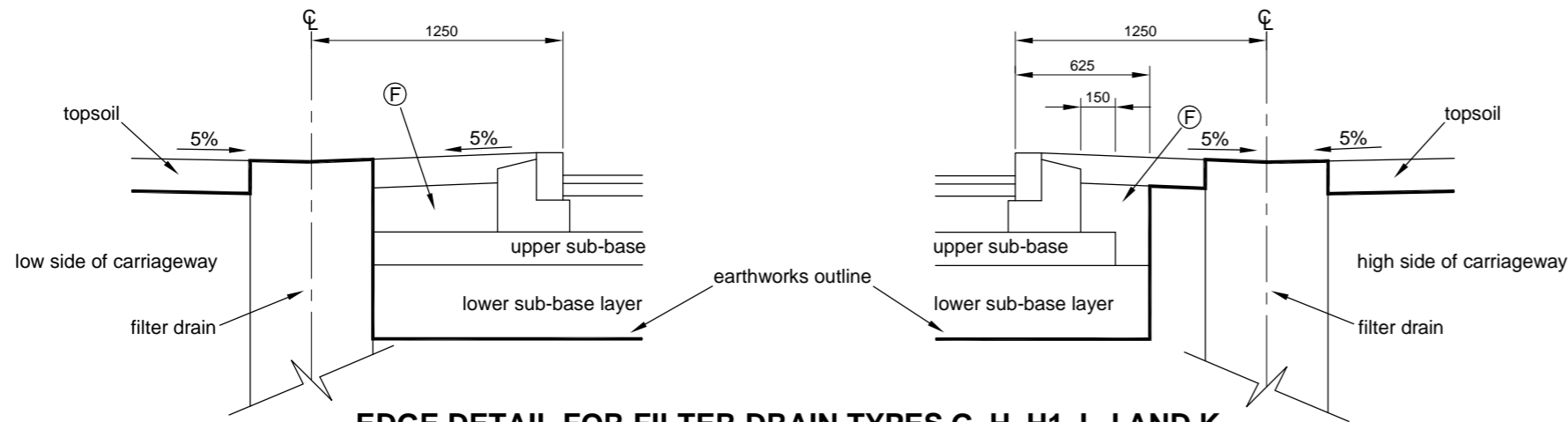

EDGE DETAIL FOR FILTER DRAIN TYPES G, H, H1, I, J AND K

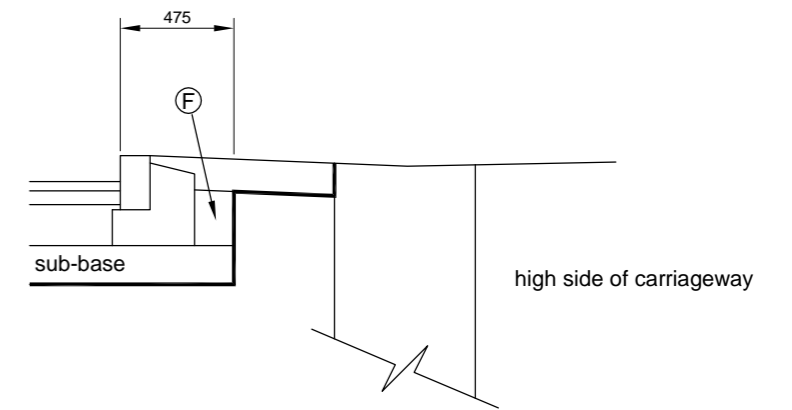

EARTHWORKS OUTLINE AND (F) WHERE NO LOWER SUB-BASE LAYER SPECIFIED

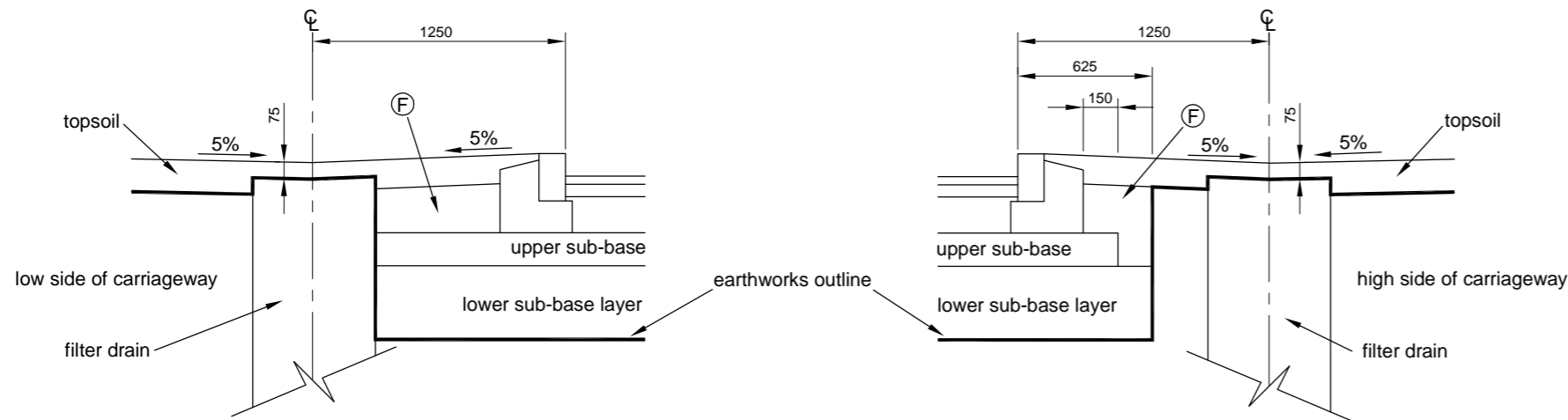

EDGE DETAIL FOR FILTER DRAIN TYPES L AND M

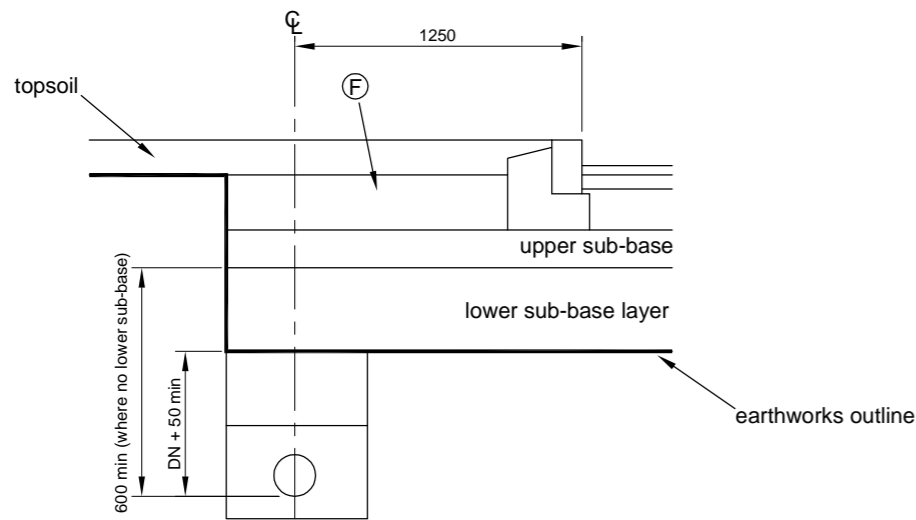

EDGE DETAIL FOR FILTER DRAIN TYPE Q (GROUP F8)

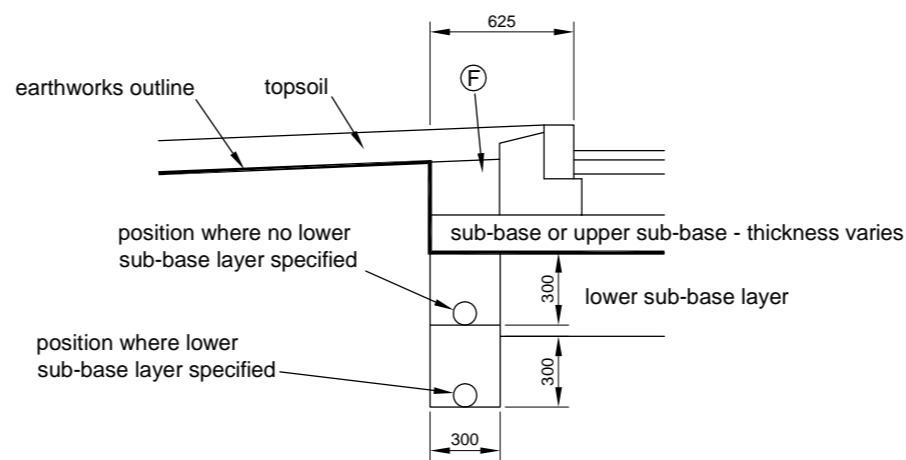

EDGE DETAIL FOR FILTER DRAIN TYPE P (GROUP F7)

NOTES

1. All dimensions are in millimetres unless stated otherwise.
2. Depth of topsoil shall be 150mm unless stated otherwise.
3. (F) = Fill material on sub-base material and base (roadbase).
4. Refer to F 701.1 for surface water drain details.
5. Refer to F 702.1 and F 702.2 for filter drain details.
6. Refer to Appendix 5/1 for pipe and bedding alternatives.
7. DN denotes nominal diameter of pipe.
8. Lower sub-base is W75 or W150 sub-base to clause 890AR.



**HIGHWAY
CONSTRUCTION
DETAILS**

TITLE 1

**EDGE OF PAVEMENT
DETAILS**

TITLE 2

**CARRIAGEWAYS WITH
CONCRETE KERBING**

| PREVIOUS ISSUES | | ALL DIMENSIONS IN MILLIMETRES UNLESS STATED OTHERWISE | ORIGINAL DRAWING SIZE 420mm x 297mm | |
|-----------------|----------|---|-------------------------------------|-----------------|
| ISSUE | DATE | | DRN | RJB |
| 1 | FEB 2005 | NOT TO SCALE | | CHKD CS |
| DRG NO. | | B 701.1 | ISSUE STATUS | 2 |
| | | | ISSUE DATE | MAY 2010 |

0mm 50mm 100mm 150mm 200mm

This plot was produced from a digital source so may not be at true scale. It is the recipient's responsibility to confirm its accuracy.

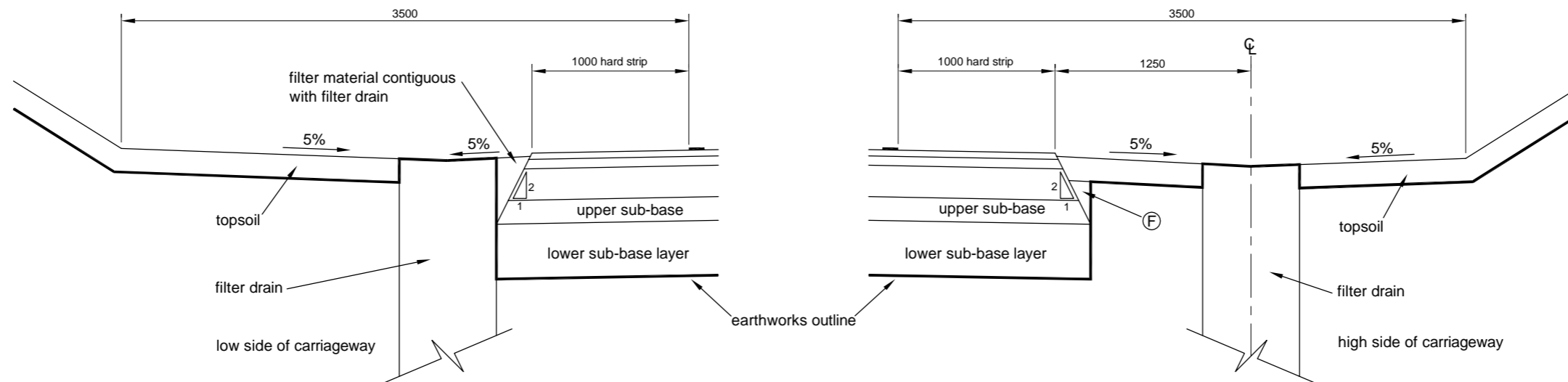

EDGE DETAIL FOR FILTER DRAINS IN CUTTING

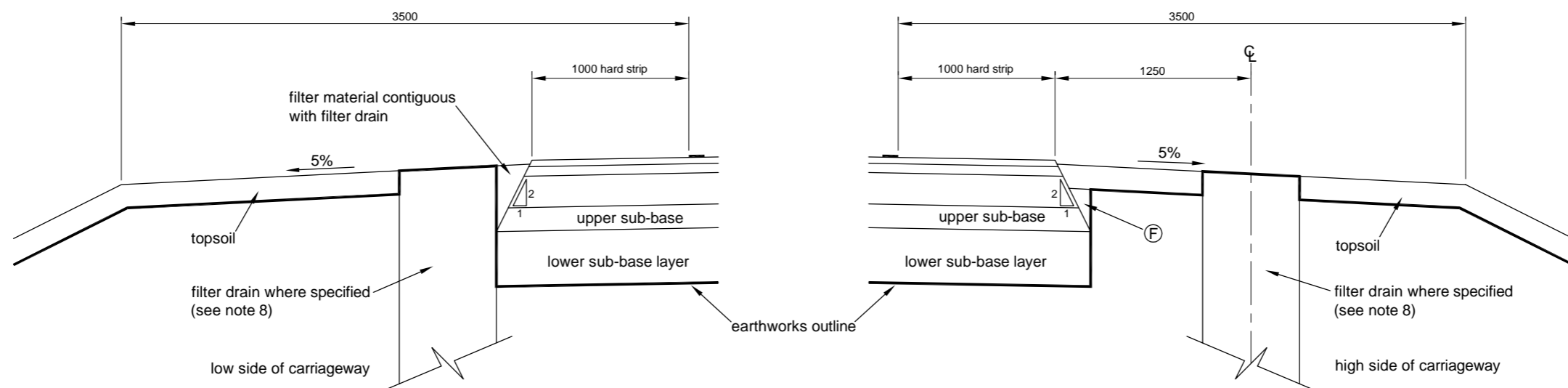

EDGE DETAIL FOR FILTER DRAINS ON EMBANKMENT

NOTES

1. All dimensions are in millimetres unless stated otherwise.
2. Depth of topsoil shall be 150mm unless stated otherwise.
3. (F) = Fill material on sub-base material and base.
4. Refer to A 701.1 and A 701.2 for cross section details beyond the back of verge.
5. Refer to A 701.1 for details of embankments without filter drains.
6. Refer to F 702.1 and F 702.2 for filter drain details.
7. Refer to Appendix 5/1 for pipe and bedding alternatives.
8. Filter drains shall only be provided on embankment verges where the pipes can be located within the existing ground beneath the embankment. In other cases, filter drains shall be located at the foot of the embankment. Refer to A 701.1 and A 701.2 for details.
9. Lower sub-base is W75 or W150 sub-base to clause 890AR.



**HIGHWAY
CONSTRUCTION
DETAILS**

TITLE 1
**EDGE OF PAVEMENT
DETAILS**

TITLE 2
**CARRIAGEWAYS WITHOUT
CONCRETE KERBING**

| PREVIOUS ISSUES | | ALL DIMENSIONS IN MILLIMETRES UNLESS STATED OTHERWISE | ORIGINAL DRAWING SIZE 420mm x 297mm | |
|-----------------|----------|---|-------------------------------------|----------------------------|
| ISSUE | DATE | | DRN | CHKD |
| 1 | FEB 2005 | NOT TO SCALE | RJB | CS |
| | | DRG NO. B 701.2 | ISSUE STATUS 2 | ISSUE DATE MAY 2010 |

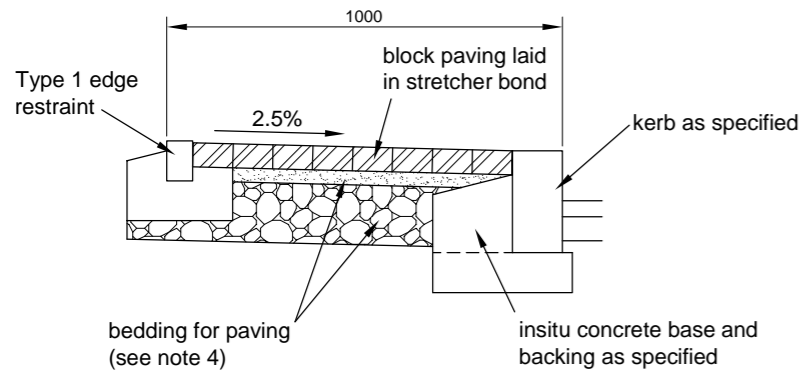

TYPE 1 ROUNDABOUT ISLAND

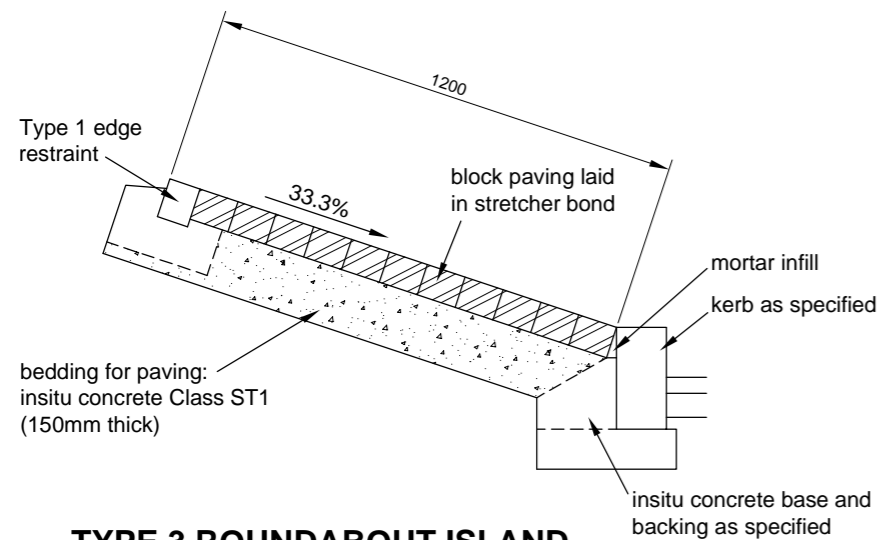

**TYPE 3 ROUNDABOUT ISLAND
(WITH CHEVRON BLOCK PAVING)**

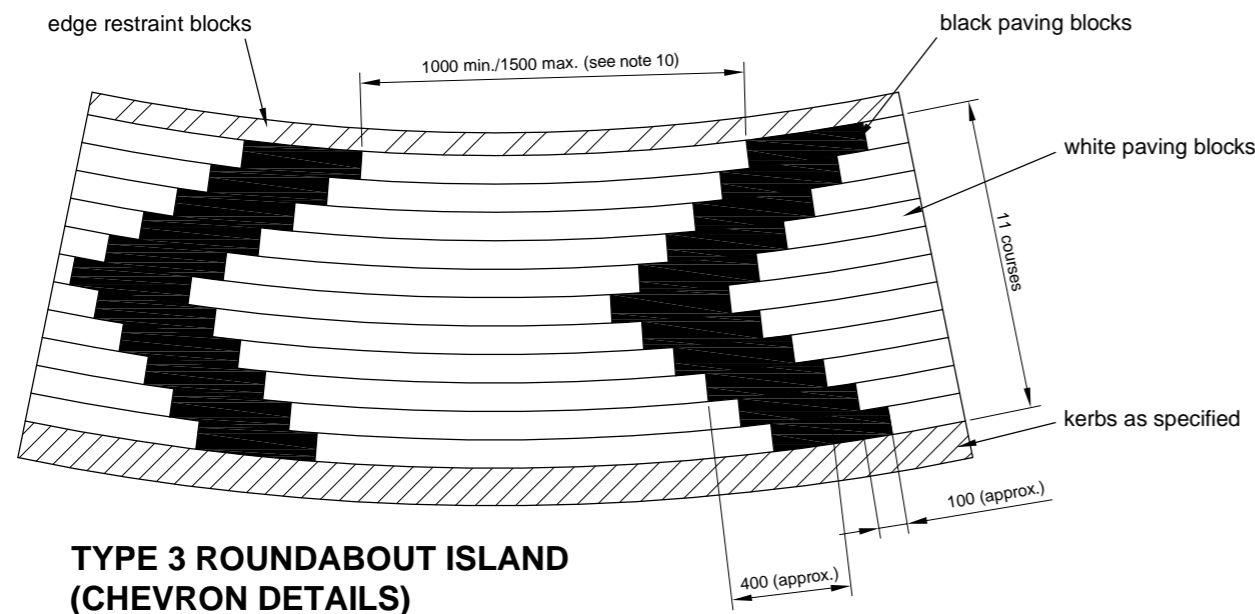

**TYPE 3 ROUNDABOUT ISLAND
(CHEVRON DETAILS)**

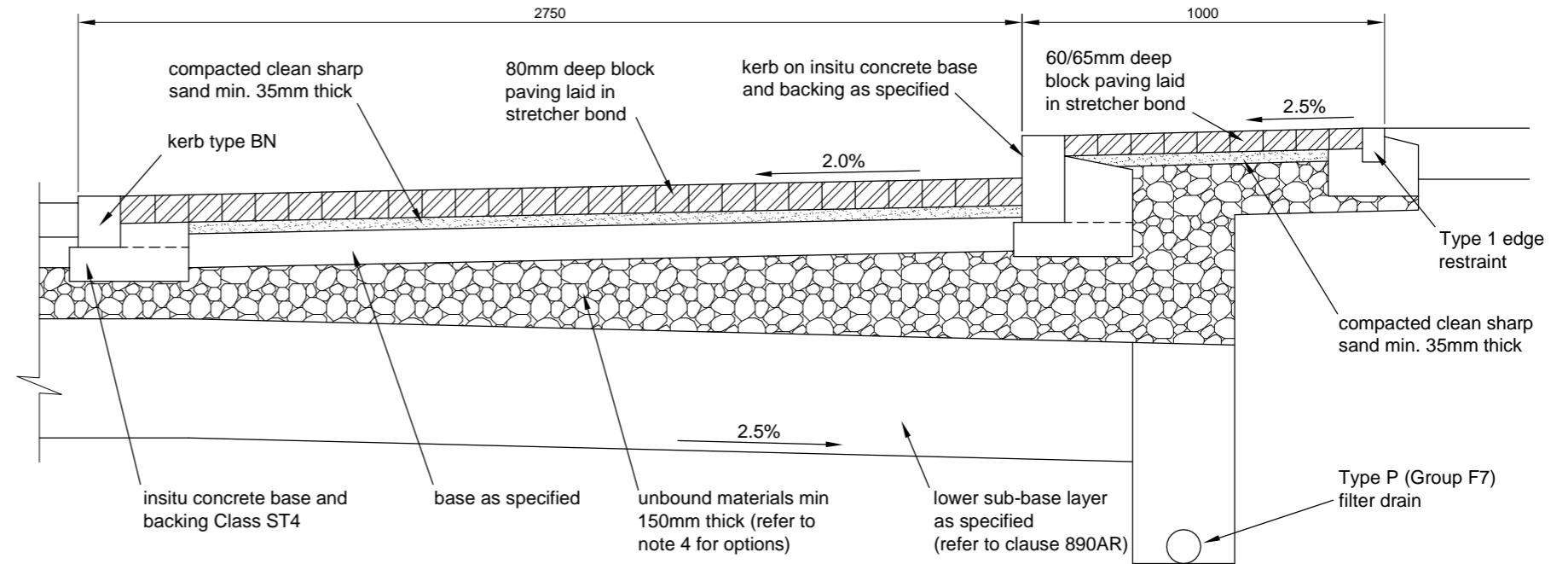

**TYPE 2 ROUNDABOUT ISLAND
(INCLUDING OVER-RUN AREA)**

NOTES

1. All dimensions are in millimetres unless stated otherwise.
2. Blocks, and the laying of blocks shall comply with S.H.W. Clause 1107.
3. Block dimensions shall be 200mm x 100mm x 60/65mm for Type 1 roundabout islands, and 200mm x 100mm x 80mm for Type 2 and 3 roundabout islands.
4. Block paving for Type 1 roundabout islands shall be bedded on compacted clean sharp sand 35mm thick underlaid with Type 1 Unbound Mixtures to S.H.W Clause 803, Type 2 Unbound Mixtures (if they contain at least 80% bituminous planings) to S.H.W Clause 804 or Type 3 (open graded) Unbound Mixtures to S.H.W Clause 805, 150mm thick.
5. Block paving for Type 3 roundabout islands shall be laid while the concrete bedding remains plastic (max. 6 hrs after batching).
6. 'Black' paving blocks shall have a black resin bonded finish. 'White' paving blocks shall have a white resin bonded reflective finish with applied solid glass beads.
7. Block paving shall be supported (on edges other than the kerbside edge) by edge restraint Types 1 or 2 (as shown on B 704.3), or by the edging for bituminous paving shown on B 702.1.
8. Refer to Appendix 11/1 for block paving details including edge restraint details.
9. Where blocks are laid in stretcher bond on curves, cut blocks shall be inserted where necessary so that joints on adjacent rows are no closer together than one quarter of a block length.
10. On Type 3 roundabout islands, chevrons shall be spaced equally. The number of chevrons will depend on the size of the roundabout, but the spacing between chevrons shall be no less than 1000mm and no greater than 1500mm.
11. Mortar shall comply with S.H.W. Clause 2402 designation (i).



HIGHWAY
CONSTRUCTION
DETAILS

TITLE 1

EDGE OF PAVEMENT
DETAILS

TITLE 2

PAVING ON
ROUNDABOUT ISLANDS

PREVIOUS ISSUES
ISSUE DATE

| | |
|---|----------|
| 1 | FEB 2005 |
| 2 | MAY 2010 |

ALL DIMENSIONS IN
MILLIMETRES UNLESS
STATED OTHERWISE

NOT TO SCALE
DRG NO.

ORIGINAL DRAWING
SIZE 420mm x 297mm

DRN RJB
ISSUE STATUS 3

CHKD CS
ISSUE DATE OCT 2010

B 701.3

3

OCT 2010

0mm 50mm 100mm 150mm 200mm

This plot was produced from a digital source so may not be at true scale. It is the recipient's responsibility to confirm its accuracy.

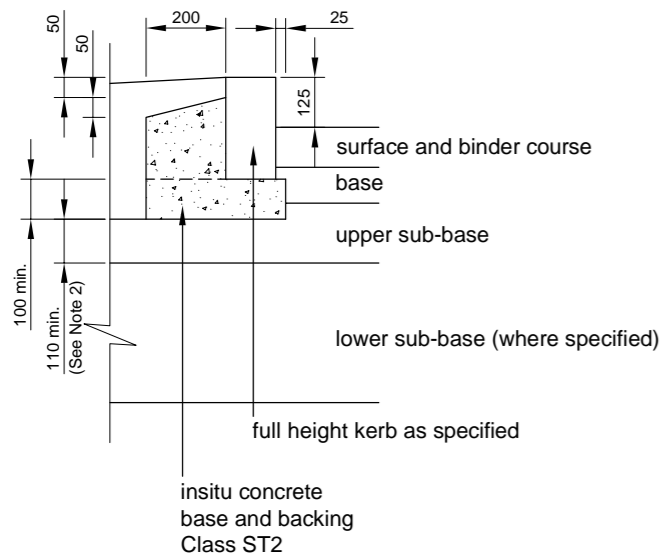

**KERBING DETAIL:
FULL HEIGHT KERBS**

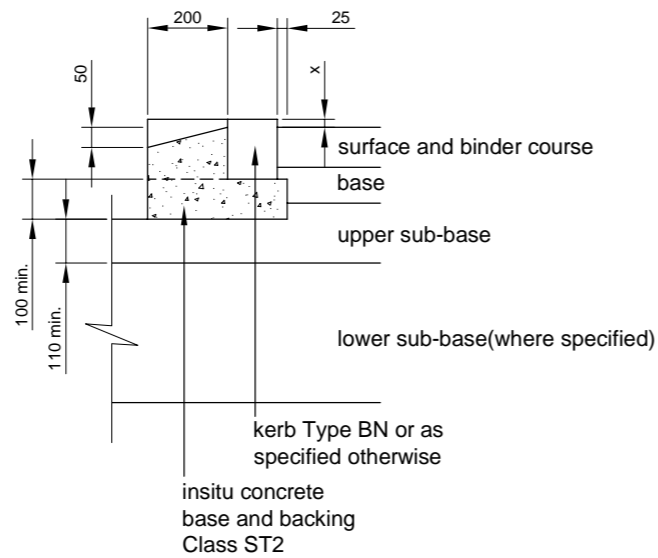

**KERBING DETAIL:
DROPPED KERBS**

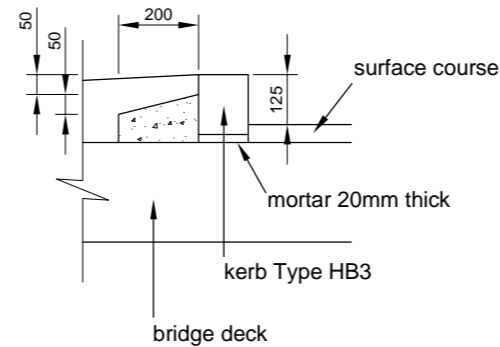

**KERBING DETAIL:
KERBS OVER BRIDGE DECKS**

NOTES

1. All linear dimensions are in millimetres unless stated otherwise. All angular dimensions are in degrees.
2. The kerb base shall sit directly on sub-base at either its design level or lower. The minimum depth of kerb base shall be 100mm and the minimum thickness of sub-base below kerb base shall be 110mm or 150mm where no lower sub-base is specified.
3. All vertical faces on kerb base and backing shall be formed with shuttering.
4. Kerbs shall be backed up while the kerb base remains plastic (max. 6hrs after batching).
5. Mortar shall comply with S.H.W. Clause 2404 designation (i).
6. Refer to Appendix 11/1 or scheme specific drawings for the kerbing schedule.
7. Kerb reference numbers are defined in BS EN 1340:2003.
8. Quadrants shall be specified by type, section radius and depth (eg. QHB 305/255).
9. Dimension 'x' on the Dropped Kerb detail shall be 25mm generally, and 6mm or less on pedestrian and cycle crossings.
10. For kerblines radii not exceeding 12m, appropriate curved kerbs shall be used.
11. For kerblines radii exceeding 12m but not exceeding 20m, 610mm long straight kerbs shall be used.
12. Bond coat to clause 920 shall be applied to the carriageway surface in accordance with BS 434: Part 2 prior to the laying of extruded asphalt kerbing.
13. Refer to H.C.D.s F 15 and F 16 for Channel Detail Types 'A' to 'F'.

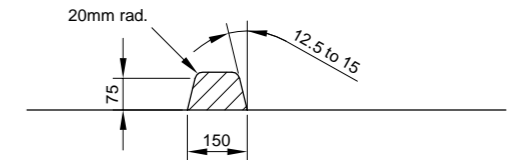

**KERBING DETAIL:
EXTRUDED ASPHALT KERBS**

| KERB TYPE | DESCRIPTION | DIMENSIONS |
|-----------|------------------------------------|------------|
| SP | 45° splayed 125mm x 255mm SP | |
| HB2 | half battered 125mm x 255mm HB2 | |
| HB3 | half battered 125mm x 150mm HB3 | |
| BN | bullnosed 125mm x 150mm BN | |

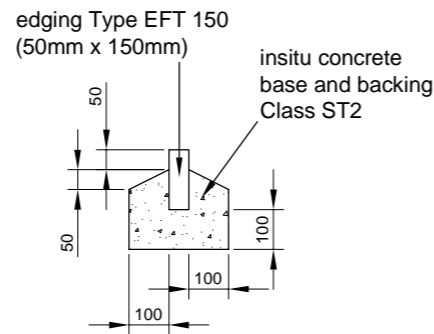

EDGING DETAIL

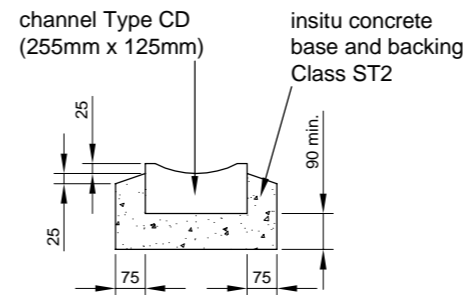

**CHANNEL DETAIL:
TYPE G**

| SPECIAL KERBS | |
|---|---|
| DROPPER KERBS:- | |
| HB2 → BN = DL1 (125mm x 255mm/150mm left hand DL1) | HB2 → SP = TL (125mm x 255mm left hand TL) |
| BN → HB2 = DR1 (125mm x 255mm/150mm right hand DR1) | SP → HB2 = TR (125mm x 255mm right hand TR) |
| QUADRANTS: | |
| BN → SP = DR2 (125mm x 255mm/150mm right hand DR2) | QSP/QHB = (455mm/305mm x 255mm QSP/QHB) |

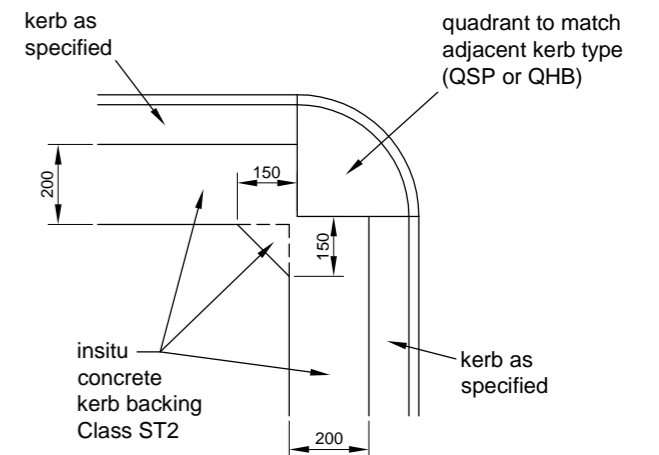

QUADRANT DETAIL



HIGHWAY
CONSTRUCTION
DETAILS

TITLE 1
EDGE OF PAVEMENT
DETAILS

TITLE 2
KERBS, EDGINGS & CHANNELS

| PREVIOUS ISSUES | | ALL DIMENSIONS IN MILLIMETRES UNLESS STATED OTHERWISE | ORIGINAL DRAWING SIZE 420mm x 297mm | |
|-----------------|----------|---|-------------------------------------|-----|
| ISSUE | DATE | | DRN | RJB |
| 1 | FEB 2005 | NOT TO SCALE | DRN | RJB |
| DRG NO. B 702.1 | | ISSUE STATUS 2 | CHKD CS | |
| | | ISSUE DATE MAY 2010 | | |

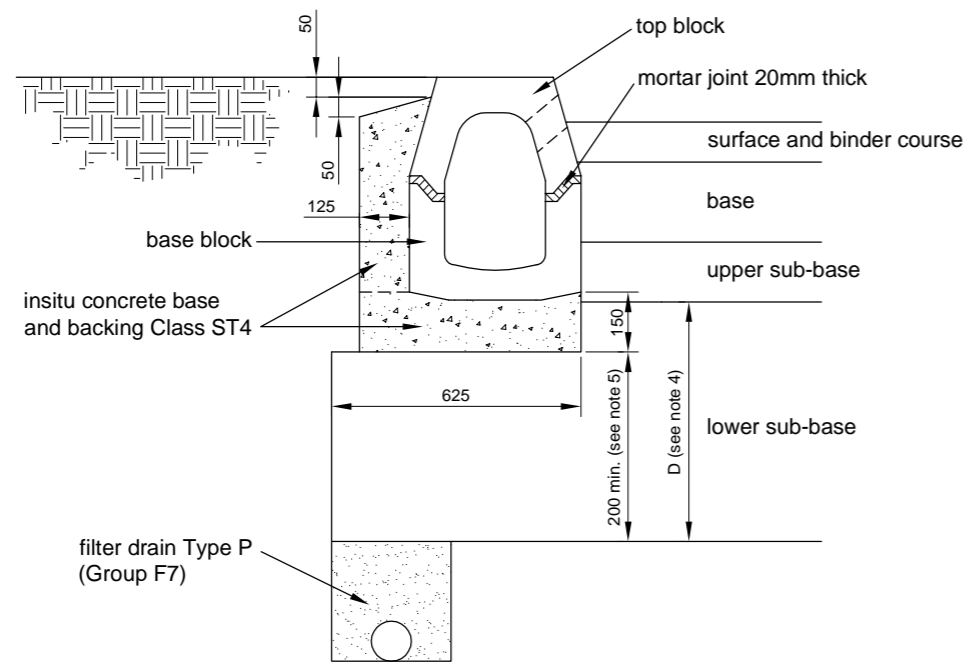

EDGE DETAIL WITH LOWER SUB-BASE LAYER

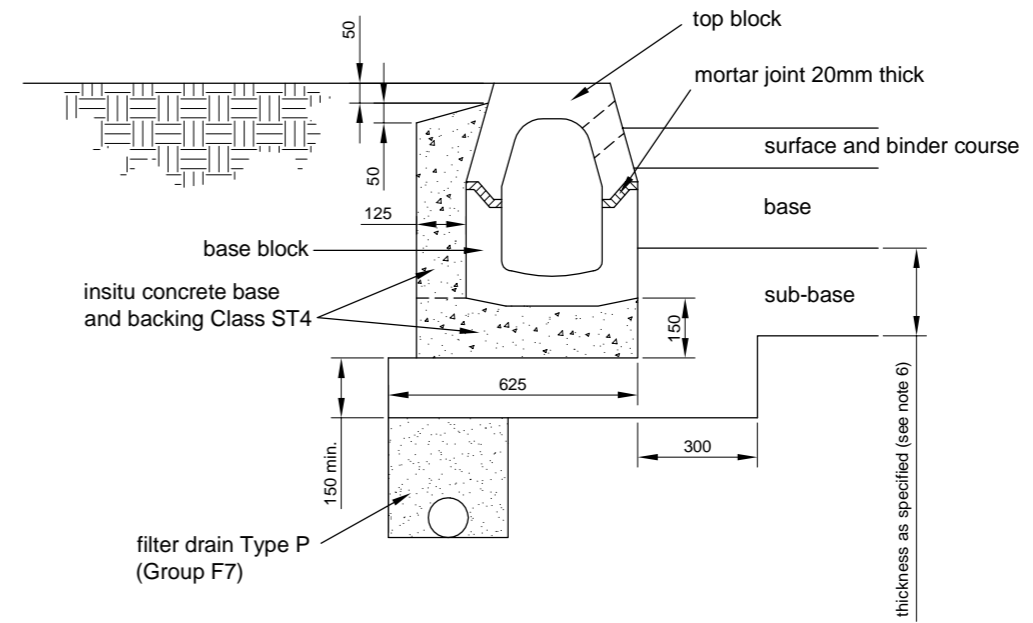

EDGE DETAIL WITHOUT LOWER SUB-BASE LAYER

NOTES

1. All dimensions are in millimetres unless stated otherwise.
2. Precast concrete combined drainage and kerb blocks shall comply with S.H.W. Clauses 516 and 1101.
3. Mortar shall comply with S.H.W. Clause 2404 designation (i).
4. Lower sub-base thickness will vary according to the CBR of sub-formation. Dimension 'D' shall be 600mm where the CBR is less than or equal to 2, otherwise 'D' shall be 350mm.
5. Where the thickness of base is less than 180mm, the thickness of the insitu concrete bed for the base block shall be reduced accordingly to maintain a minimum capping layer thickness of 200mm beneath. The thickness of insitu concrete bed shall be at least 100mm.
6. Where no lower sub-base is specified, the depth of sub-base shall be increased beneath the base block and up to a point 300mm in from the carriageway side face of the base block. The minimum thickness of sub-base below the insitu concrete bed for the base block shall be 150mm.
7. Exposed joints shall be filled with joint filler in accordance with S.H.W. Clauses 1016 and 1017.
8. The dimension between the carriageway side face of the base block and the vergeside edge of the Type P filter drain shall be 625mm.
9. Refer to Appendices 5/1 and 11/1 for the schedule of precast concrete combined drainage and kerb blocks.

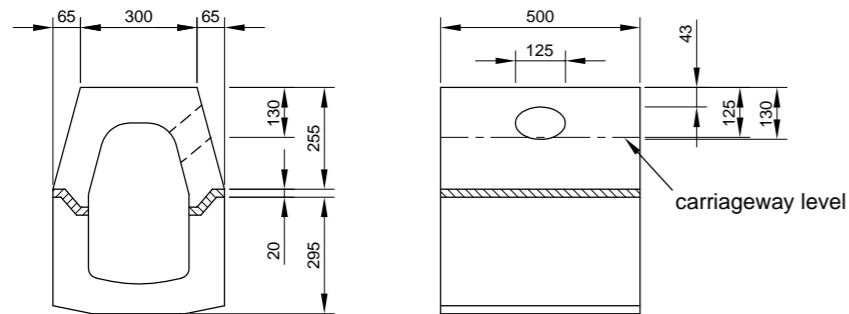

TOP AND BASE BLOCK DIMENSION DETAILS

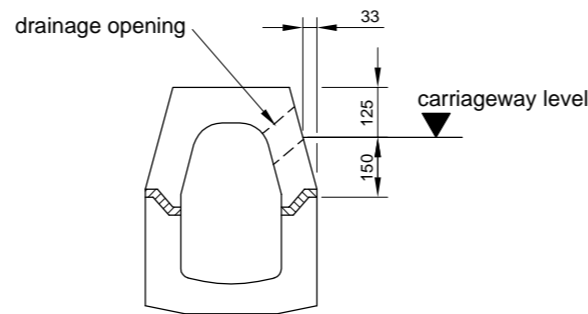

BASE BLOCK SETTING OUT DETAILS



HIGHWAY CONSTRUCTION DETAILS

TITLE 1
EDGE OF PAVEMENT DETAILS

TITLE 2
PRECAST CONCRETE COMBINED DRAINAGE & KERB BLOCKS: TYPICAL CROSS SECTIONS

| PREVIOUS ISSUES | | ALL DIMENSIONS IN MILLIMETRES UNLESS STATED OTHERWISE | ORIGINAL DRAWING SIZE 420mm x 297mm | |
|-----------------|----------|---|-------------------------------------|---------------------|
| ISSUE | DATE | | DRN | RJB |
| 1 | FEB 2005 | NOT TO SCALE | DRN | RJB |
| | | DRG NO. | B 703.1 | ISSUE STATUS 2 |
| | | | | ISSUE DATE MAY 2010 |

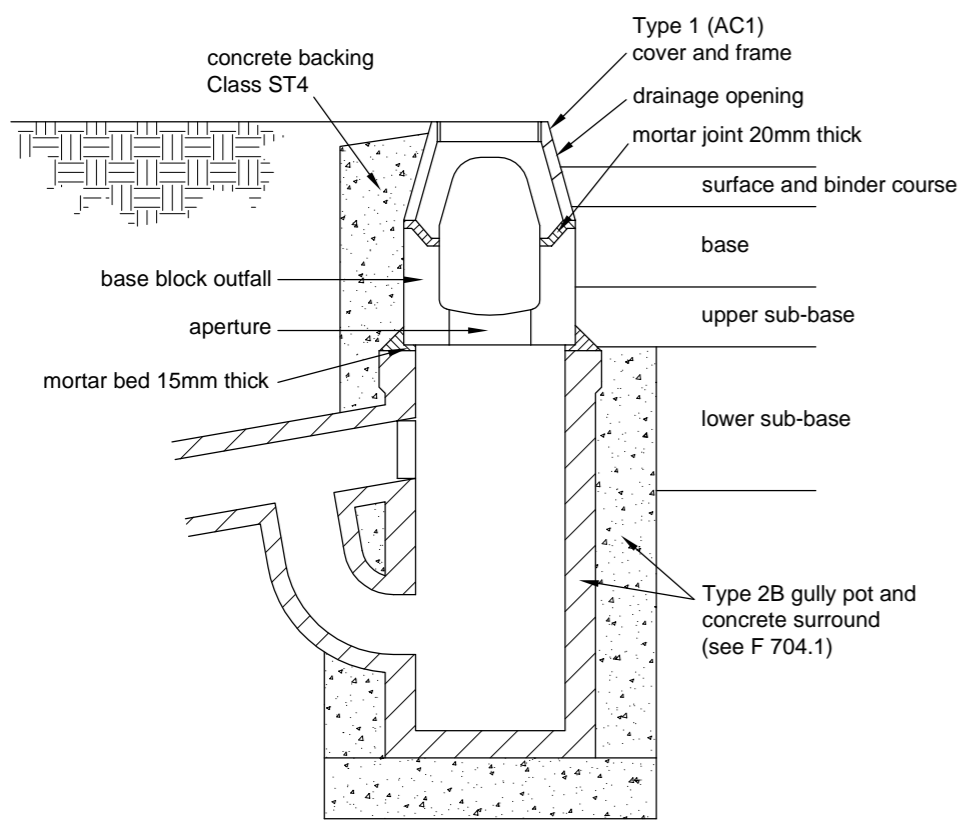

SECTION X-X

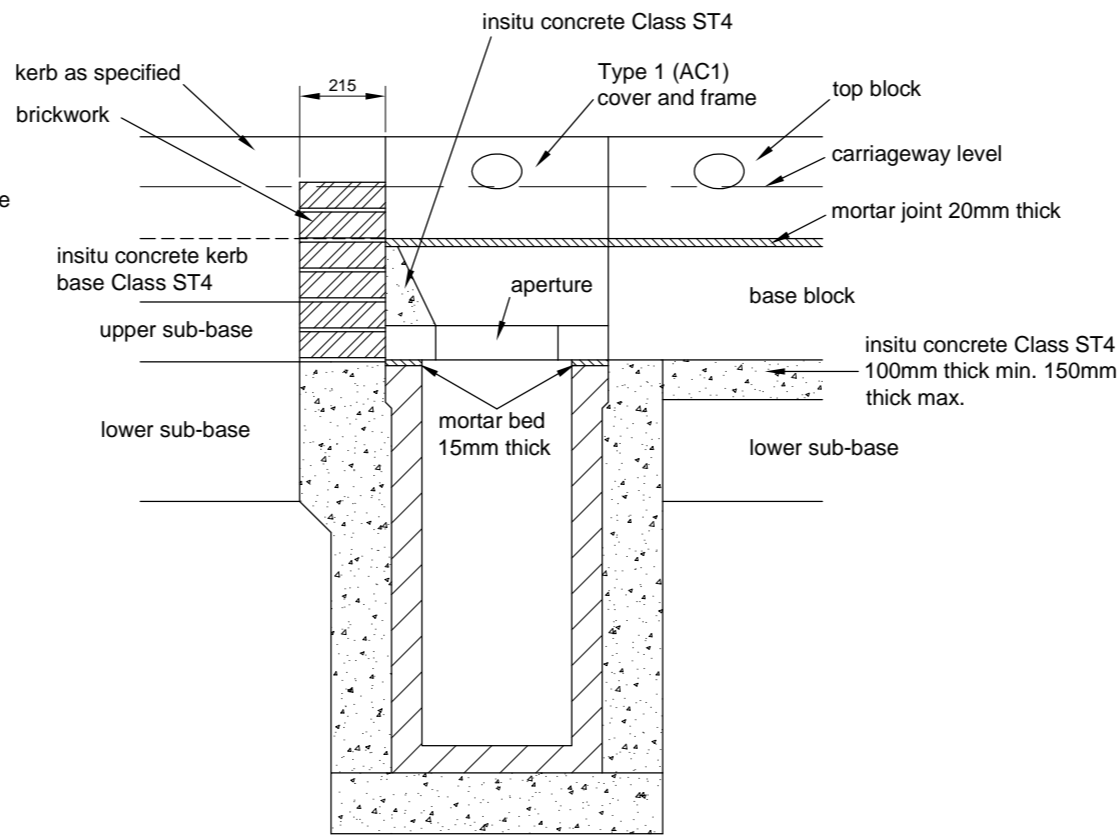

SECTION Y-Y

NOTES

1. All dimensions are in millimetres unless stated otherwise.
2. Brickwork shall be English bond and comprise Class B clay engineering bricks to BS 3921, bedded on mortar. Brickwork shall comply with S.H.W. Clauses 2406 and 2412.
3. Mortar shall comply with S.H.W. Clause 2404 designation (i).
4. Refer to F 704.1 for gully details.
5. Precast concrete combined drainage and kerb blocks shall comply with S.H.W. Clauses 516 and 1101.
6. Gullies and Type AC1 access covers shall be installed at 30m intervals unless specified otherwise on the scheme specific contract drawings.

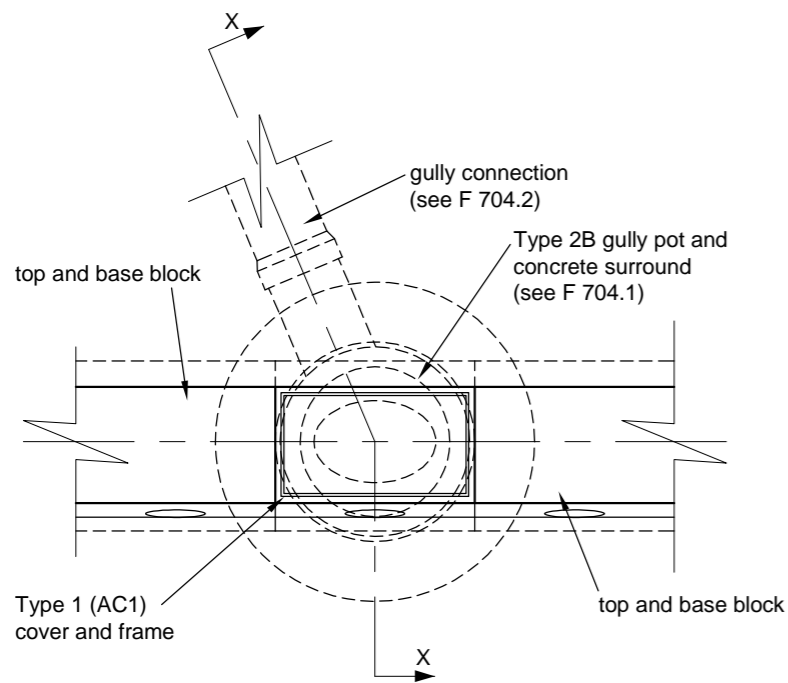

PLAN (INTERMEDIATE OUTFALL)

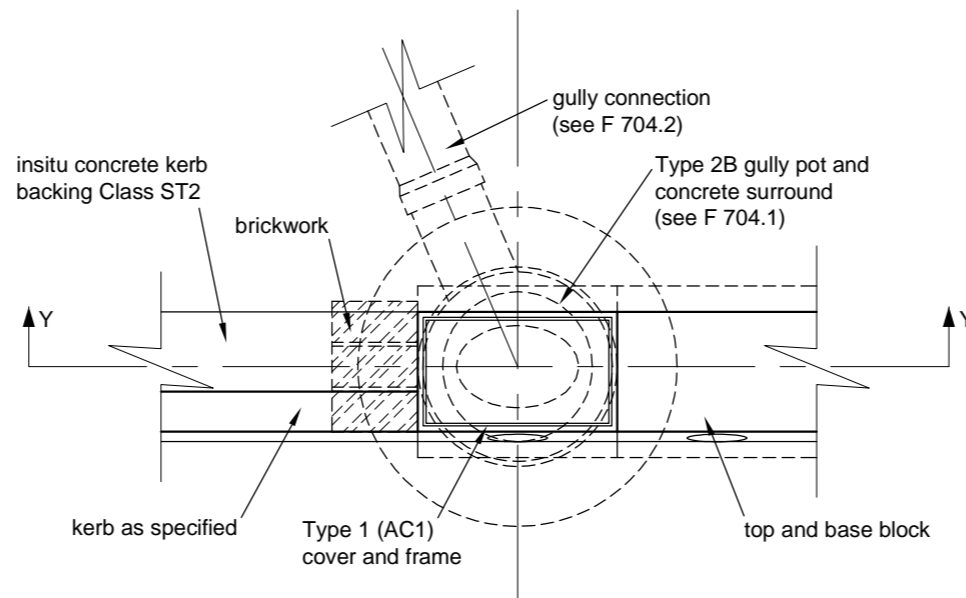

PLAN (END STOP AND OUTFALL TYPE ES01)

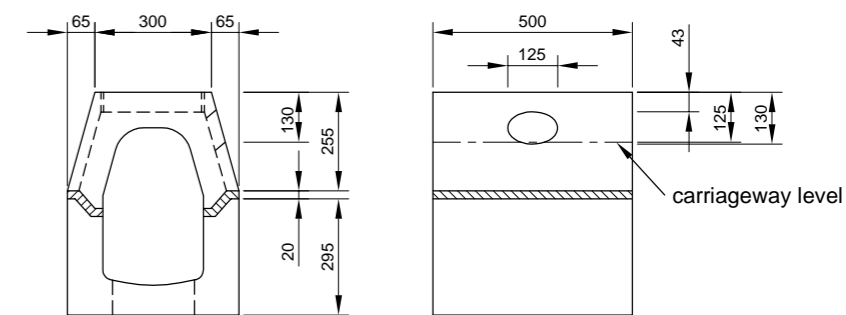

ACCESS COVER AND BASE BLOCK OUTFALL DIMENSION DETAILS



HIGHWAY CONSTRUCTION DETAILS

TITLE 1
EDGE OF PAVEMENT DETAILS

TITLE 2
PRECAST CONCRETE COMBINED DRAINAGE & KERB BLOCKS: LOW POINT END STOP & OUTFALL DETAILS

| PREVIOUS ISSUES | | ALL DIMENSIONS IN MILLIMETRES UNLESS STATED OTHERWISE | ORIGINAL DRAWING SIZE 420mm x 297mm | |
|-----------------|----------|---|-------------------------------------|----------------------------|
| ISSUE | DATE | | DRN | RJB |
| 1 | FEB 2005 | NOT TO SCALE | | CHKD CS |
| 2 | MAY 2010 | DRG NO. | B 703.2 | ISSUE STATUS 3 |
| | | | | ISSUE DATE OCT 2010 |

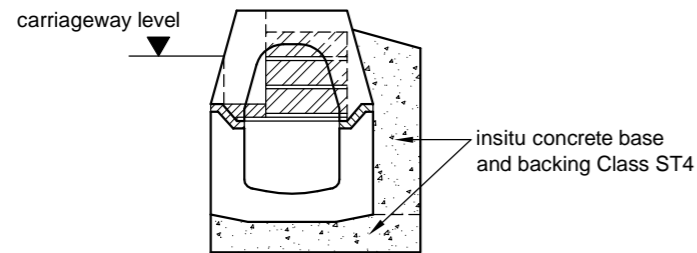

SECTION A-A

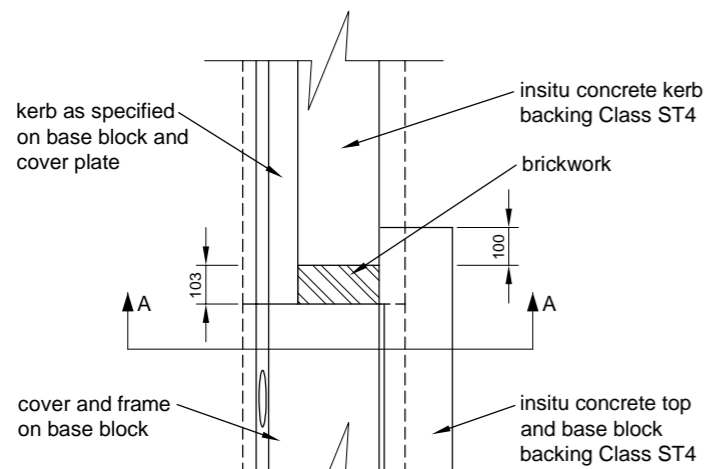

PLAN

END STOP AT BASE BLOCK WITH COVER PLATE (TYPE ESCP)

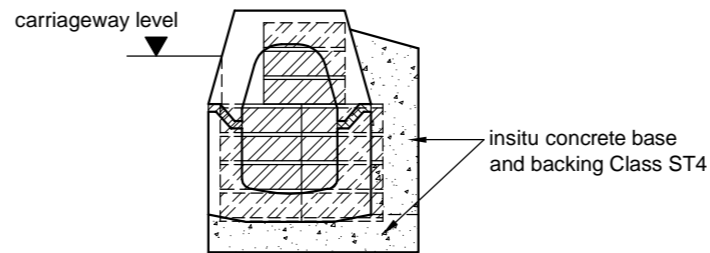

SECTION B-B

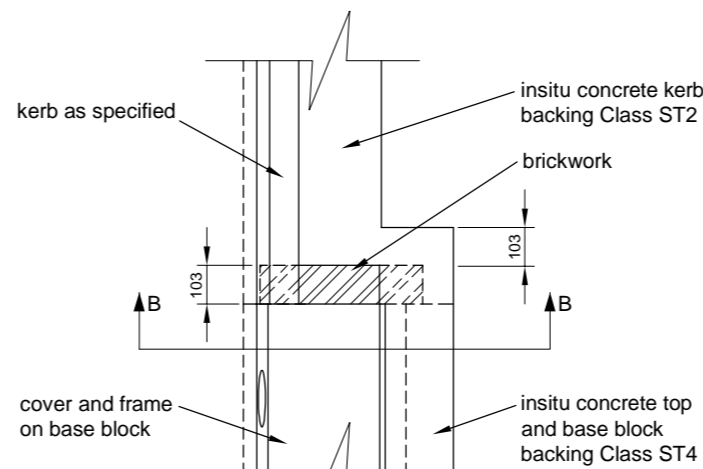

PLAN

HIGH POINT END STOP (TYPE ESHP)

NOTES

1. All dimensions are in millimetres unless stated otherwise.
2. Precast concrete combined drainage and kerb blocks shall comply with S.H.W. Clauses 516 and 1101.
3. Brickwork shall be English bond and comprise Class B clay engineering bricks to BS 3921, bedded on mortar. Brickwork shall comply with S.H.W. Clauses 2406 and 2412.
4. Mortar shall comply with S.H.W. Clause 2404 designation (i).
5. Exposed joints shall be filled with joint filler in accordance with S.H.W. Clauses 1016 and 1017.
6. Type ESCP End Stops shall be provided at the transition from top and base block to base block with cover plate and kerb.
7. Type ESHP End Stops shall be provided at the high point transition from top and base block to specified kerbing.
8. Cover plates shall be joined with cover plate jointing tape min. 50mm wide.
9. Refer to Appendices 5/1 and 11/1 for the schedule of precast concrete combined drainage and kerb blocks.
10. Dimension insitu concrete base for combined drainage and kerb block in accordance with B703.1.

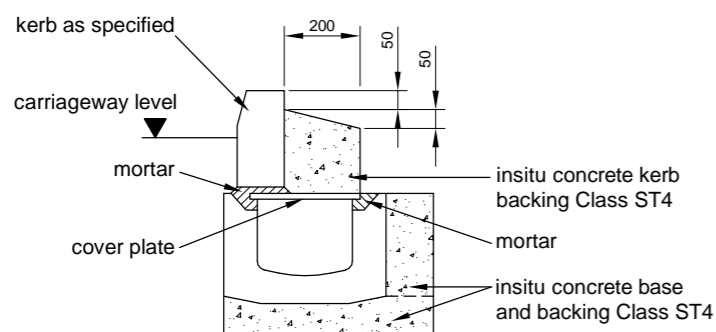

KERB ON BASE BLOCK AND COVER PLATE



HIGHWAY CONSTRUCTION DETAILS

TITLE 1
EDGE OF PAVEMENT DETAILS

TITLE 2
PRECAST CONCRETE COMBINED DRAINAGE & KERB BLOCKS: MISCELLANEOUS ITEMS

| PREVIOUS ISSUES | | ALL DIMENSIONS IN MILLIMETRES UNLESS STATED OTHERWISE | ORIGINAL DRAWING SIZE 420mm x 297mm | |
|-----------------|----------|---|-------------------------------------|----------------|
| ISSUE | DATE | | DRN | RJB |
| 1 | FEB 2005 | NOT TO SCALE | DRN | RJB |
| | | DRG NO. B 703.3 | ISSUE STATUS 2 | CHKD CS |
| | | ISSUE DATE MAY 2010 | | |

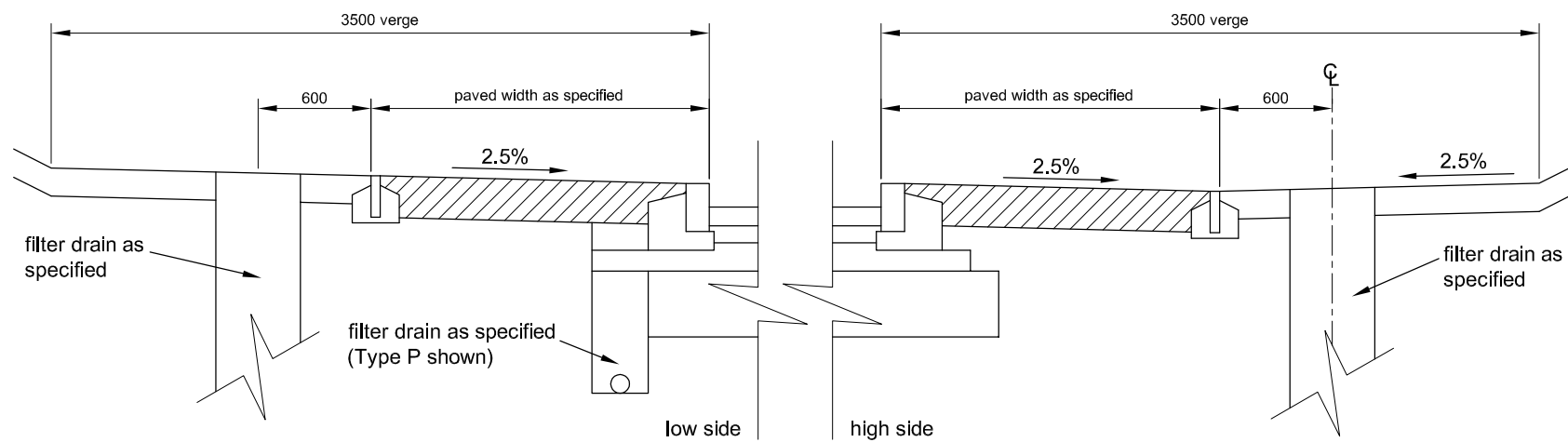

PAVED AREA ADJACENT TO CARRIAGEWAY IN CUTTING

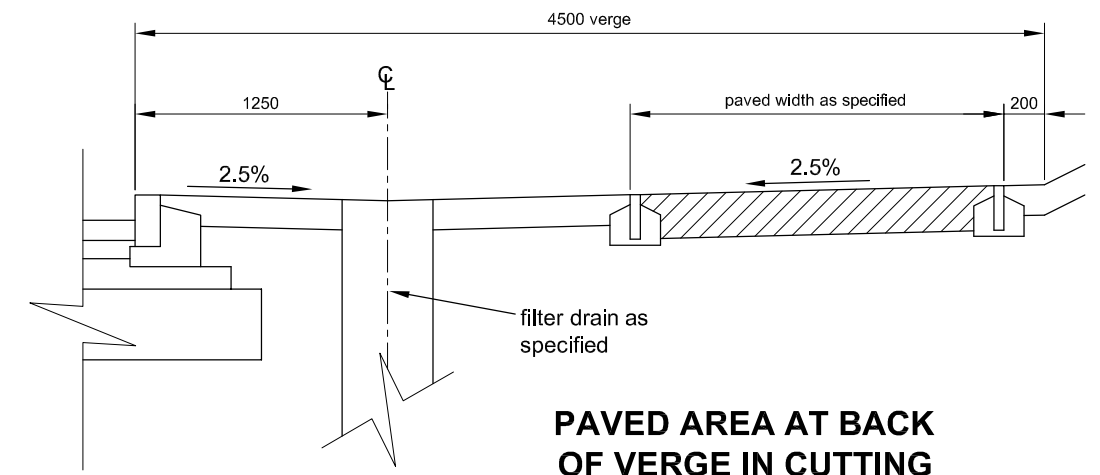

PAVED AREA AT BACK OF VERGE IN CUTTING

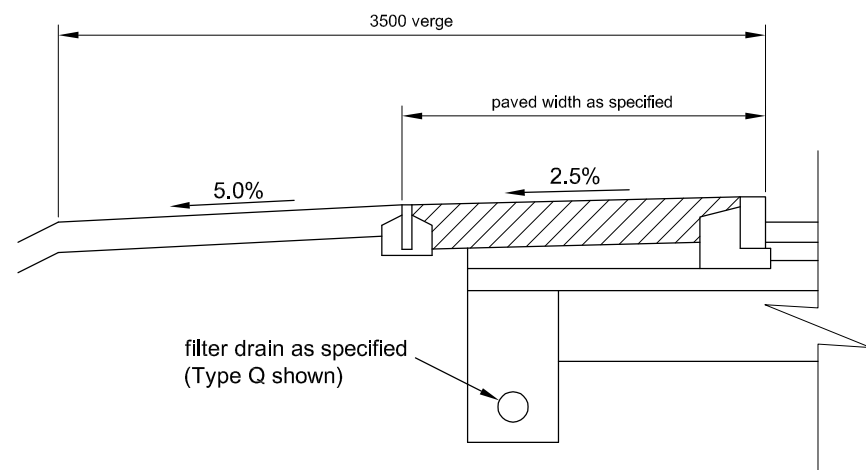

PAVED AREA ADJACENT TO CARRIAGEWAY ON EMBANKMENT

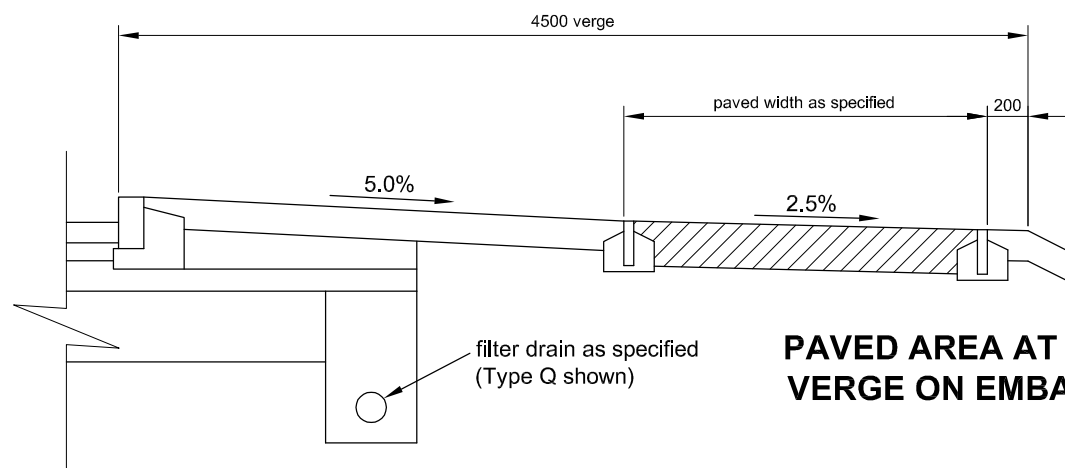

PAVED AREA AT BACK OF VERGE ON EMBANKMENT

NOTES

- All dimensions are in millimetres unless stated otherwise.
- The material specifications for 55/6F surf, 45/6F surf and 45/10F surf are given in appendix 0/1 and Annex D of the County Council's Surfacing and Structural Maintenance Strategy. The material specification for 55/10F surf is given in PD 6691, Table C2A.
- Footways and cycleways crossing accesses shall be constructed in accordance with the relevant access construction requirements of B 704.2.
- Machine laying of bituminous layers is the default option. Permission to hand lay must be sought from the Overseeing Organisation. Except for circumstances where it is not possible, cycleways and combined footways/cycleways shall be machine laid.

KEY

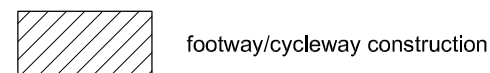

CONSTRUCTION FOR BITUMINOUS FOOTWAYS, CYCLEWAYS AND COMBINED FOOTWAYS/CYCLEWAYS

| Construction Type | Thickness | Specification | Notes |
|-------------------------------------|-----------|--|--|
| Type 1: (footways only) | 20mm | Surface Course: HRA 55/6F surf 100/150 (HRA 45/6F 160/220 if hand laid) | To be used on untrafficked footways only, where there is no risk of vehicle loading. The two bituminous layers may be replaced by a single 50mm layer of HRA 55/10F surf 100/150 Surface Course (HRA 45/10F 160/220 if hand laid) |
| | 50mm | Binder Course: AC20 dense bin 100/150 (160/220 binder may be used in winter when hand laying) | |
| | 100mm | Sub-base: Type 1 Unbound Mixtures to S.H.W Clause 803, Type 2 Unbound Mixtures (if they contain at least 80% bituminous planings) to S.H.W Clause 804 or Type 3 (open graded) Unbound Mixtures to S.H.W Clause 805 | |
| Type 2: (footways and cycleways) | 20mm | Surface Course: HRA 55/6F surf 100/150 (HRA 45/6F 160/220 if hand laid) | To be used on footways and cycleways trafficked only by light vehicles and where there is no risk of heavy vehicle loading. The two bituminous layers may be replaced by a single 50mm layer of HRA 55/10F surf 100/150 Surface Course (HRA 45/10F 160/220 if hand laid) |
| | 50mm | Binder Course: AC20 dense bin 100/150 (160/220 binder may be used in winter when hand laying) | |
| | 150mm | Sub-base: Type 1 Unbound Mixtures to S.H.W Clause 803, Type 2 Unbound Mixtures (if they contain at least 80% bituminous planings) to S.H.W Clause 804 or Type 3 (open graded) Unbound Mixtures to S.H.W Clause 805 | |
| Type 3: (footways and cycleways) | 20mm | Surface Course: HRA 55/6F surf 100/150 (HRA 45/6F 160/220 if hand laid) | To be used on footways and cycleways occasionally trafficked by heavy vehicles. The two bituminous layers may be replaced by a single 50mm layer of HRA 55/10F surf 100/150 Surface Course (HRA 45/10F 160/220 if hand laid) |
| | 50mm | Binder Course: AC20 dense bin 100/150 (160/220 binder may be used in winter when hand laying) | |
| | 225mm | Sub-base: Type 1 Unbound Mixtures to S.H.W Clause 803, Type 2 Unbound Mixtures (if they contain at least 80% bituminous planings) to S.H.W Clause 804 or Type 3 (open graded) Unbound Mixtures to S.H.W Clause 805 | |
| Type 4: (footways and cycleways) | 25mm | Surface Course: HRA 55/6F surf 100/150 (HRA 45/6F 160/220 if hand laid) | To be used on footways and cycleways frequently trafficked by heavy vehicles. |
| | 90mm | Base: AC28 dense base 100/150 (160/220 binder may be used in winter when hand laying) | |
| | 365mm | Sub-base: Type 1 Unbound Mixtures to S.H.W Clause 803, Type 2 Unbound Mixtures (if they contain at least 80% bituminous planings) to S.H.W Clause 804 or Type 3 (open graded) Unbound Mixtures to S.H.W Clause 805 | |



HIGHWAY CONSTRUCTION DETAILS

TITLE 1

EDGE OF PAVEMENT DETAILS

TITLE 2

FOOTWAY & CYCLEWAY CONSTRUCTION

| PREVIOUS ISSUES | | ALL DIMENSIONS IN MILLIMETRES UNLESS STATED OTHERWISE | ORIGINAL DRAWING SIZE 420mm x 297mm | |
|-----------------|----------|---|-------------------------------------|---------------------|
| ISSUE | DATE | | DRN | RJB |
| 1 | FEB 2005 | NOT TO SCALE | DRN | RJB |
| 2 | MAY 2010 | DRG NO. | B 704.1 | ISSUE STATUS 4 |
| 3 | OCT 2010 | | | ISSUE DATE FEB 2013 |

0mm | 50mm | 100mm | 150mm | 200mm

This plot was produced from a digital source so may not be at true scale. It is the recipient's responsibility to confirm its accuracy.

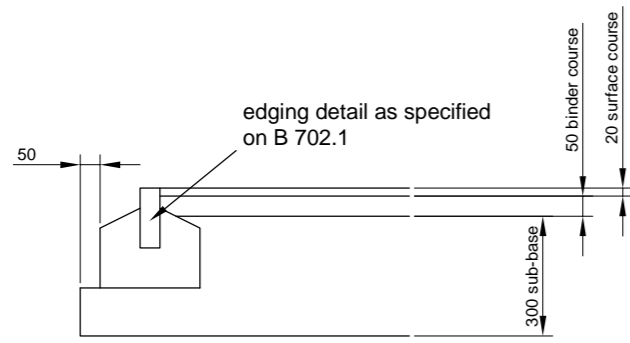

TYPE 1 ACCESS DETAIL

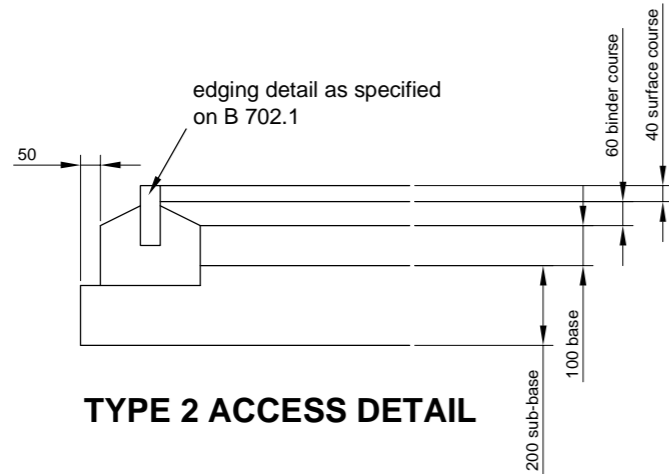

TYPE 2 ACCESS DETAIL

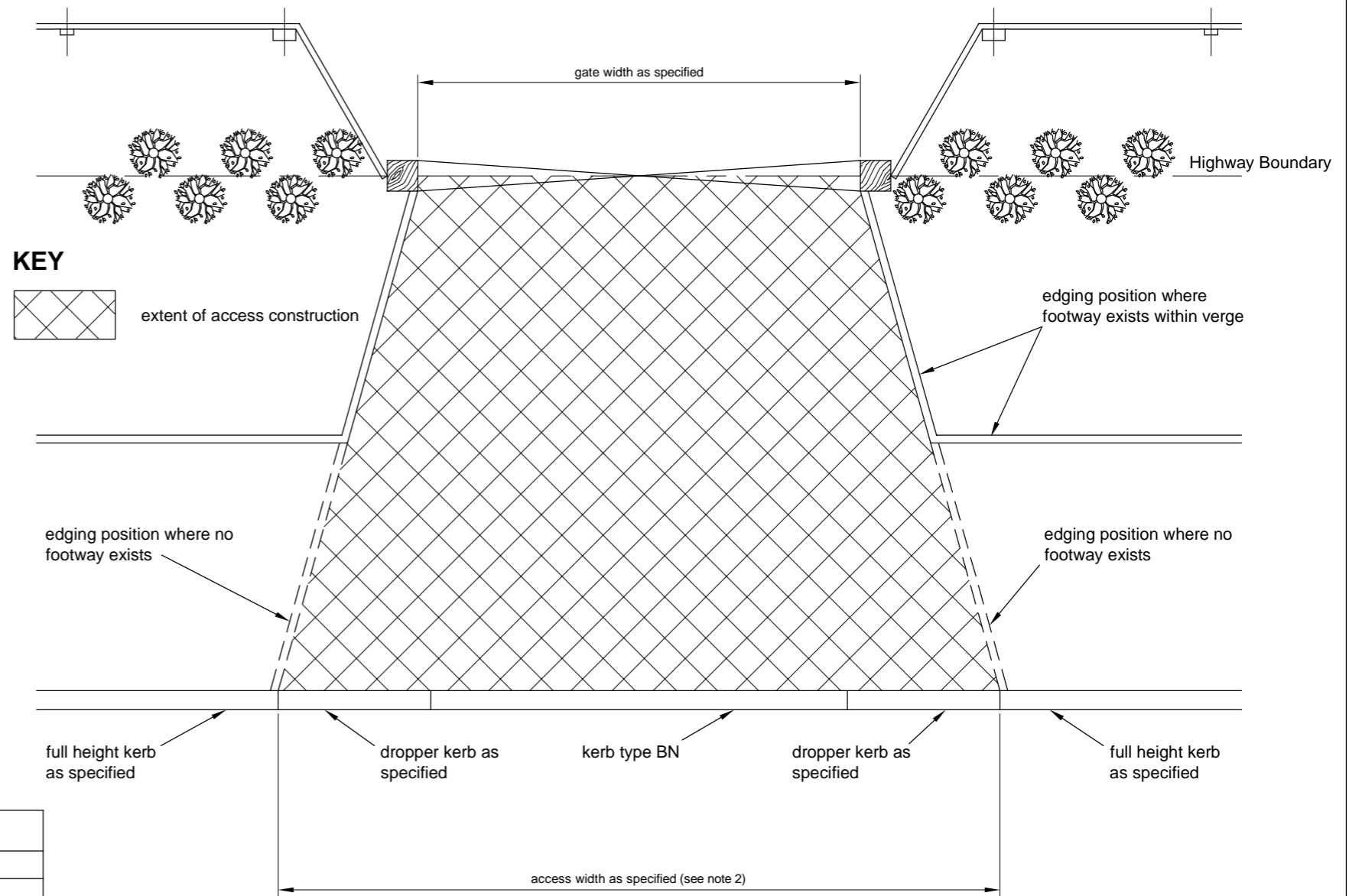

ACCESS LAYOUT

| ACCESS CONSTRUCTION | | | |
|---------------------|-----------|--|---|
| Construction Type | Thickness | Specification | Notes |
| Type 1 | 20mm | Surface Course: HRA 55/6F surf 100/150 (HRA 45/6F 160/220 if hand laid) | For residential use. The two bituminous layers may be replaced by a single 60mm layer of HRA 55/10F surf 100/150 Surface Course (HRA 45/10F 160/220 if hand laid) |
| | 50mm | Binder Course: AC20 dense bin 100/150 (160/220 binder may be used in winter when hand laying) | |
| | 300mm | Sub-base: Type 1 Unbound Mixtures to S.H.W Clause 803, Type 2 Unbound Mixtures (if they contain at least 80% bituminous planings) to S.H.W Clause 804 or Type 3 (open graded) Unbound Mixtures to S.H.W Clause 805 | |
| Type 2 | 40mm | Surface Course: HRA 55/6F surf 100/150 (HRA 45/6F 160/220 if hand laid) | For industrial use |
| | 60mm | Binder Course: AC20 dense bin 100/150 (160/220 binder may be used in winter when hand laying) | |
| | 100mm | Base: AC28 dense bin 100/150 (160/220 binder may be used in winter when hand laying) | |
| | 200mm | Sub-base: Type 1 Unbound Mixtures to S.H.W Clause 803, Type 2 Unbound Mixtures (if they contain at least 80% bituminous planings) to S.H.W Clause 804 or Type 3 (open graded) Unbound Mixtures to S.H.W Clause 805 | |

NOTES

- All dimensions are in millimetres unless stated otherwise.
- The access width dimension shall be such that it may be constructed using a whole number of uncut dropper and bull nose kerbs.
- The longitudinal vertical alignment of the access centreline shall be:
 - a straight upward or downward gradient where the slope between carriageway channel and foot of gate posts is 5% or less.
 - a straight upward or downward gradient at 5% between carriageway channel and a point 3m in from the kerb, followed by a steeper gradient (not exceeding 10%) to the foot of gate posts where the average slope exceeds 5%.
- Refer to Appendix 11/1 for edging upstand specification. If no upstand dimension is specified, the surface course shall be laid flush with the top of edging.
- Filter drains beneath access construction shall be Type Q (Group F8). Refer to F 702.2 for details.



HIGHWAY CONSTRUCTION DETAILS

TITLE 1

EDGE OF PAVEMENT DETAILS

TITLE 2

ACCESS CONSTRUCTION

| PREVIOUS ISSUES | | ALL DIMENSIONS IN MILLIMETRES UNLESS STATED OTHERWISE | ORIGINAL DRAWING SIZE 420mm x 297mm | |
|-----------------|----------|---|-------------------------------------|------------|
| ISSUE | DATE | | DRN | RJB |
| 1 | FEB 2005 | NOT TO SCALE | DRN | RJB |
| 2 | MAY 2010 | DRG NO. | B 704.2 | |
| | | ISSUE STATUS | 3 | ISSUE DATE |
| | | | | OCT 2010 |

0mm 50mm 100mm 150mm 200mm

This plot was produced from a digital source so may not be at true scale. It is the recipient's responsibility to confirm its accuracy.

LAYING PATTERNS

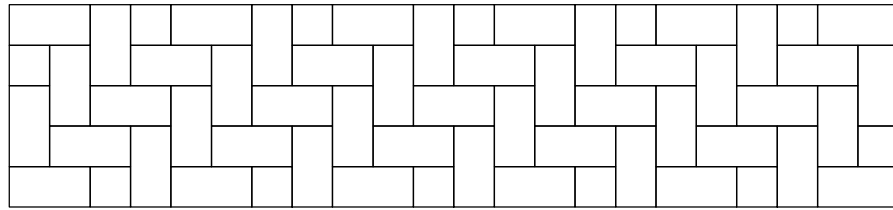

SQUARE HERRINGBONE

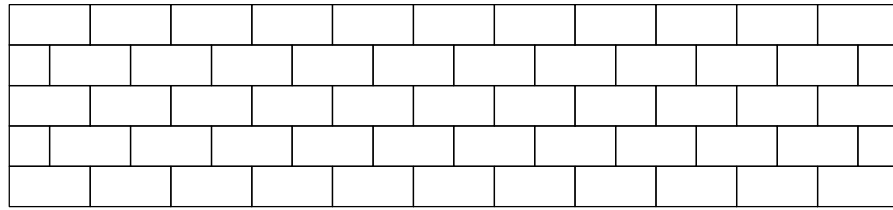

STRETCHER

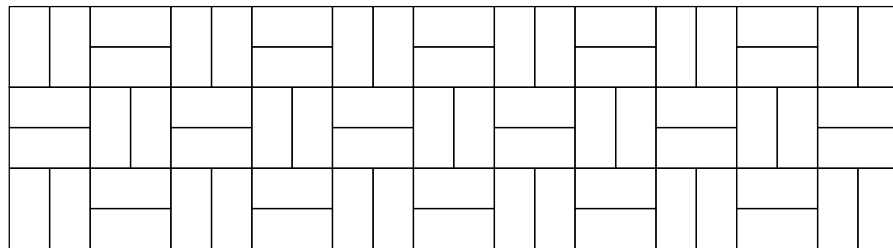

BASKET WEAVE

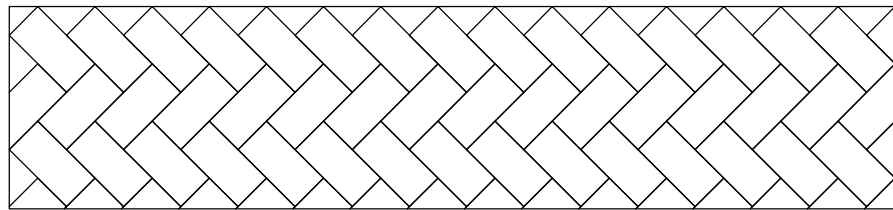

45° HERRINGBONE

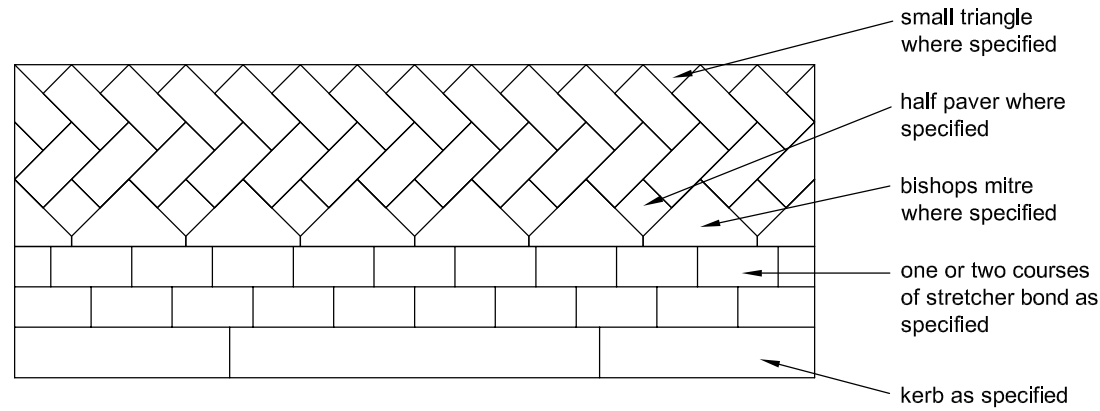

KERBSIDE EDGE DETAILS

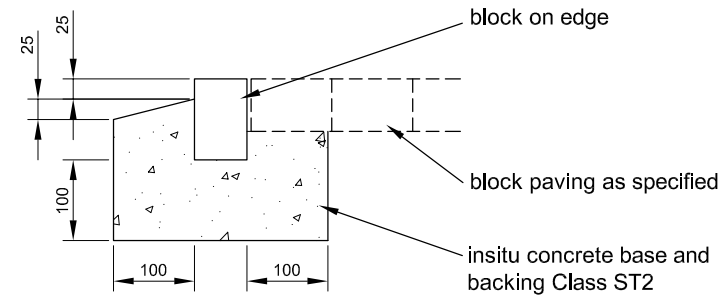

TYPE 1 EDGE RESTRAINT

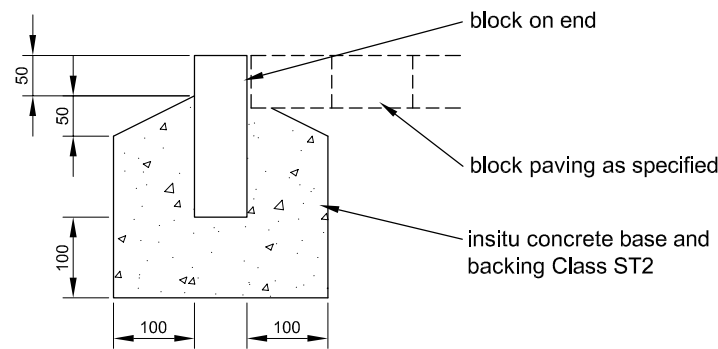

TYPE 2 EDGE RESTRAINT

NOTES

1. All dimensions are in millimetres unless stated otherwise.
2. Blocks, and the laying of blocks shall comply with S.H.W. Clause 1107.
3. Blocks dimensions shall be 200mm x 100mm x 80/65/60mm.
4. Block paving shall be bedded on compacted clean sharp sand 35mm thick underlaid with Type 1 Unbound Mixtures to S.H.W Clause 803, Type 2 Unbound Mixtures (if they contain at least 80% bituminous planings) to S.H.W Clause 804) or Type 3 (open graded) Unbound Mixtures to S.H.W Clause 805, 150mm thick.
5. Block paving shall be supported (on edges other than the kerbside edge) by edge restraint Type 1 or Type 2, or by the edging for bituminous paving shown on B 702.1.
6. Refer to Appendix 11/1 for block paving details including edge restraint details.
7. Where blocks are laid in stretcher bond on curves, cut blocks shall be inserted where necessary so that joints on adjacent rows are no closer together than one quarter of a block length.
8. Stretcher bond and basket weave shall not be used on areas subject to vehicular traffic.



**HIGHWAY
CONSTRUCTION
DETAILS**

TITLE 1

**EDGE OF PAVEMENT
DETAILS**

TITLE 2

BLOCK PAVING

| | | | | |
|-----------------|----------|---|-------------------------------------|---------------------|
| PREVIOUS ISSUES | | ALL DIMENSIONS IN MILLIMETRES UNLESS STATED OTHERWISE | ORIGINAL DRAWING SIZE 420mm x 297mm | |
| ISSUE | DATE | | DRN | RJB |
| 1 | FEB 2005 | NOT TO SCALE | | CHKD CS |
| | | DRG NO. | B 704.3 | ISSUE STATUS 2 |
| | | | | ISSUE DATE MAY 2010 |

0mm | 50mm | 100mm | 150mm | 200mm

This plot was produced from a digital source so may not be at true scale. It is the recipient's responsibility to confirm its accuracy.

NOTES

1. All dimensions are in millimetres unless stated otherwise.
2. Refer to B 702.1 for edge detail with HB2 type kerbs.
3. Where the footway width exceeds 4m, the maximum width of the boarding point shall be 3m. Where the footway width does not exceed 4m, the boarding point width shall be as the footway width. The back edge of the boarding point shall tie in with existing footway levels. Edging kerbs shall be laid along the back edge of the paving area unless the footway boundary is formed by a wall or other structure.
4. Paving flags shall be bedded on Type 1 Unbound Mixtures to S.H.W Clause 803, Type 2 Unbound Mixtures (if they contain at least 80% bituminous planings) to S.H.W Clause 8 or Type 3 (open graded) Unbound Mixtures to S.H.W Clause 805, 150mm thick (lower layer), and sand 35mm thick (top layer).
5. Road marking material shall be yellow thermoplastic screed with applied solid glass beads.
6. Damaged or excavated carriageway along the line of new kerbs shall be reinstated in accordance with the longitudinal jointing details shown on B 705.1.
7. The maximum length and width of the bus bay shall be 19m and 3m respectively.
8. Carriageway reinstatement shall be in accordance with the longitudinal construction joint detail shown on B705.1.
9. Sign to Diag. 974 to be erected on bus stop pole.

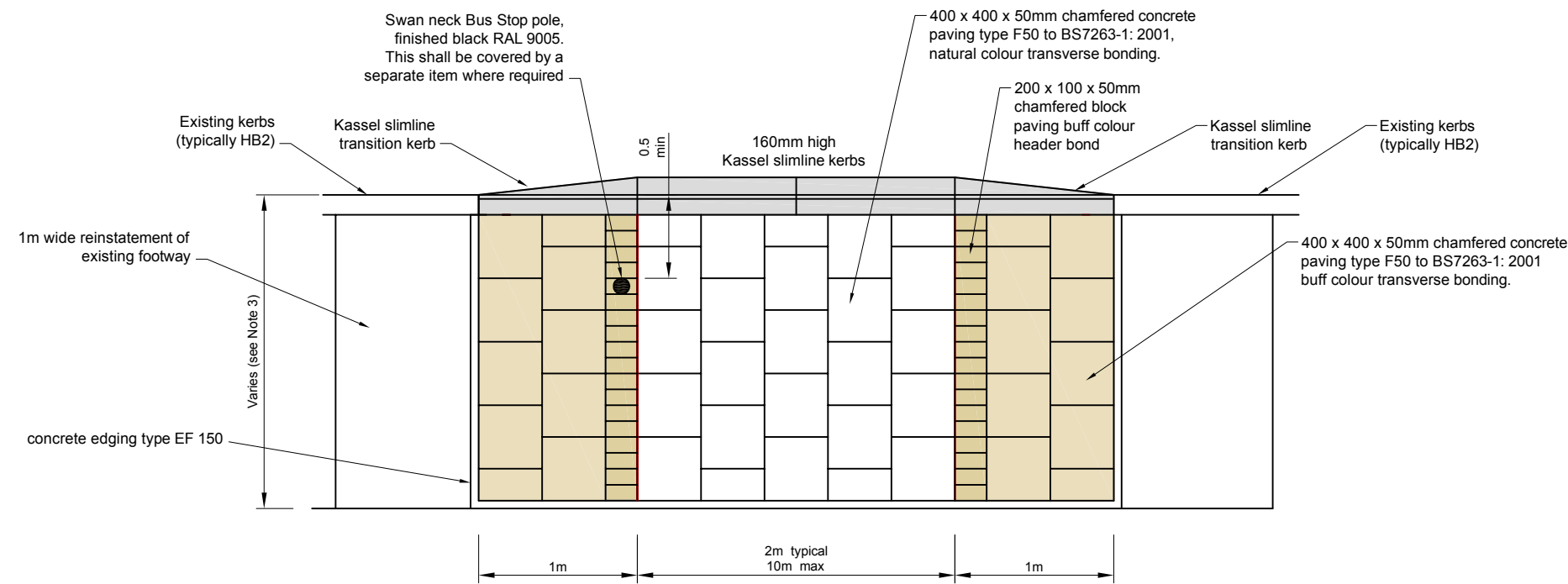

PAVING DETAIL FOR BOARDING POINT WITH "SLIMLINE KASSEL" KERBS

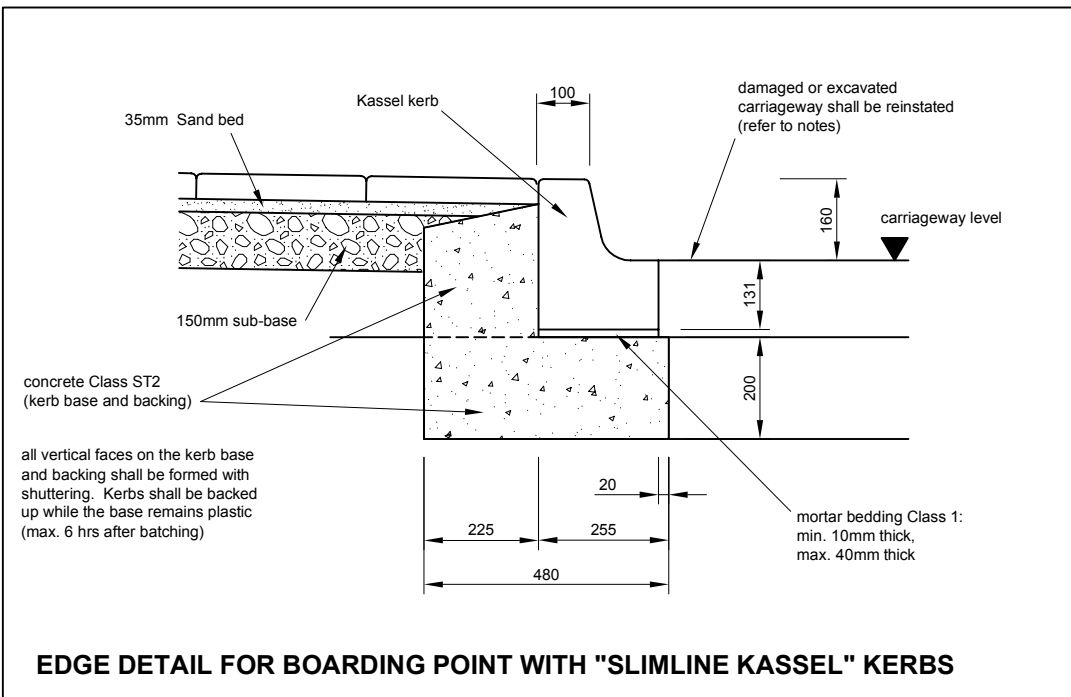

EDGE DETAIL FOR BOARDING POINT WITH "SLIMLINE KASSEL" KERBS

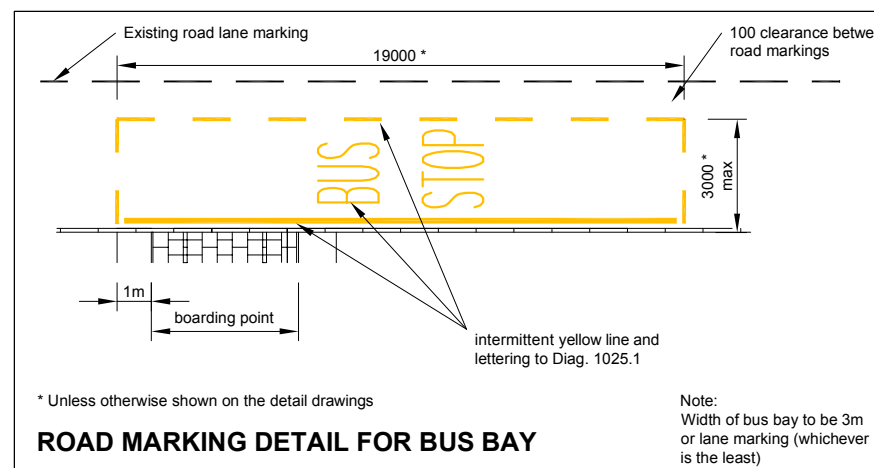

ROAD MARKING DETAIL FOR BUS BAY



**HIGHWAY
CONSTRUCTION
DETAILS**

TITLE 1
EDGE OF PAVEMENT DETAILS

TITLE 2
**BUS BOARDING POINT (QUALITY BUS CORRIDOR)
WITH KASSEL KERBS**

| PREVIOUS ISSUES | | ALL DIMENSIONS IN MILLIMETRES UNLESS STATED OTHERWISE | ORIGINAL DRAWING SIZE 420mm x 297mm | | | |
|-----------------|----------|---|-------------------------------------|------------|--------------|----|
| ISSUE | DATE | | DRN | RJB | CHKD | CS |
| 1 | FEB 2005 | NOT TO SCALE | | | | |
| 2 | MAY 2010 | DRG NO. | B 704.4 | | ISSUE STATUS | 3 |
| | | | | ISSUE DATE | JULY 2012 | |

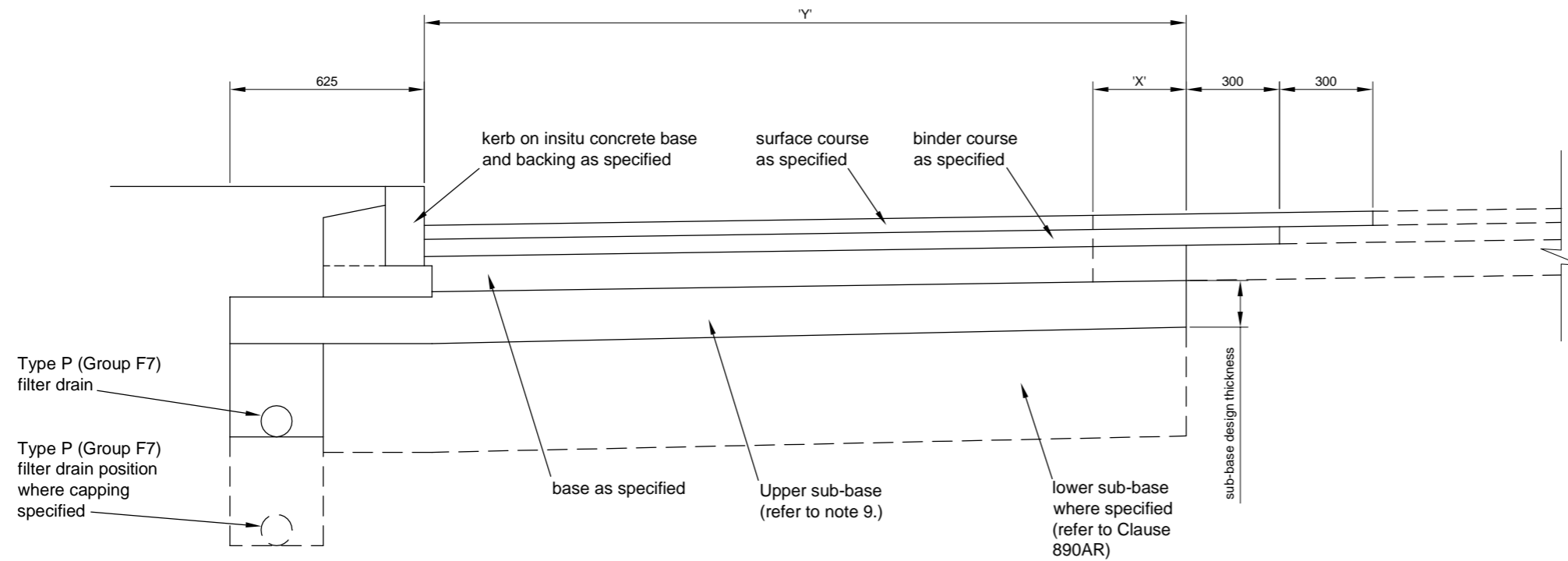

STRIP WIDENING SECTION THROUGH LOW SIDE OF CARRIAGEWAY

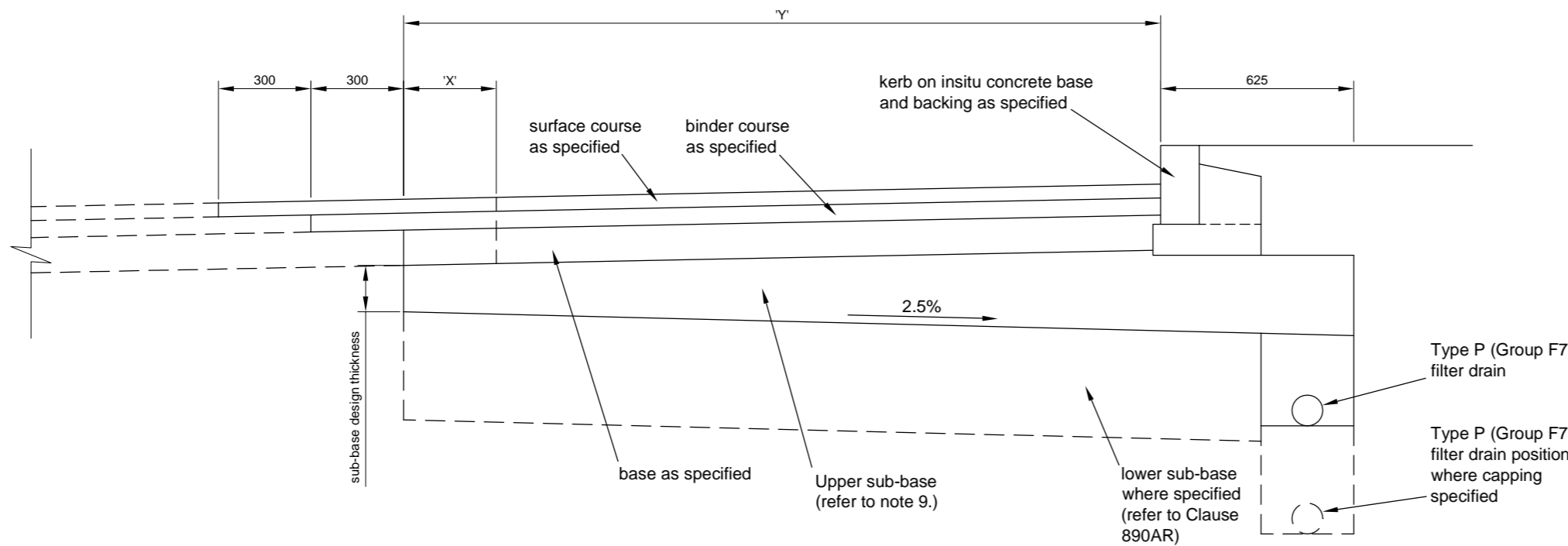

STRIP WIDENING SECTION THROUGH HIGH SIDE OF CARRIAGEWAY

NOTES

1. All dimensions are in millimetres unless stated otherwise.
2. 45/6, 45/10, and 55/10F Rolled Asphalt surface courses shall be as specified in the contract, or where no contract specification applies, in accordance with WCC's Surfacing and Structural Maintenance Strategy. All regulating material shall comply with S.H.W. Series 900.
3. Longitudinal joints in the surface course shall be saw cut.
4. Sub-base and granular fill material shall not be laid directly onto existing bituminous materials. Affected bituminous layers shall be excavated and the resultant void filled with the appropriate free draining granular material.
5. Bond coat to clause 920 shall be applied to all previously trafficked surfaces which are to be overlaid.
6. Dimension 'X' (the cut-back distance from the existing carriageway edge into existing carriageway material) shall be determined by the Overseeing Organisation following an inspection of the condition of existing carriageway materials. For the purpose of tender pricing, assume 500mm.
7. Dimension 'Y' (the width of new full construction) shall be determined in accordance with the principles outlined in note 6, but shall be no less than 375mm. Where narrow sections of widening occur to the extent that bituminous materials could not be adequately compacted, either cement bound material (approved in advance by the Overseeing Organisation) or in-situ concrete Class ST3 shall be used in lieu of bituminous binder course and/or base material.
8. Type P (Group F7) filter drains are shown for schematic purposes only. Refer to Appendix 5/1 and scheme specific drawings for filter drain details.
9. Upper sub-base shall be Type 1 Unbound Mixtures to S.H.W. Clause 803, Type 2 Unbound Mixtures (if they contain at least 80% bituminous planings) to S.H.W Clause 804 or Type 3 (open graded) Unbound Mixtures to S.H.W Clause 805.



HIGHWAY CONSTRUCTION DETAILS

TITLE 1
EDGE OF PAVEMENT DETAILS

TITLE 2
STRIP WIDENING & LONGITUDINAL JOINTING DETAILS

| PREVIOUS ISSUES | | ALL DIMENSIONS IN MILLIMETRES UNLESS STATED OTHERWISE | ORIGINAL DRAWING SIZE 420mm x 297mm | |
|-----------------|----------|---|-------------------------------------|---------------------|
| ISSUE | DATE | | DRN | RJB |
| 1 | FEB 2005 | NOT TO SCALE | | |
| | | DRG NO. | B 705.1 | ISSUE STATUS 2 |
| | | | | ISSUE DATE MAY 2010 |

0mm 50mm 100mm 150mm 200mm

This plot was produced from a digital source so may not be at true scale. It is the recipient's responsibility to confirm its accuracy.

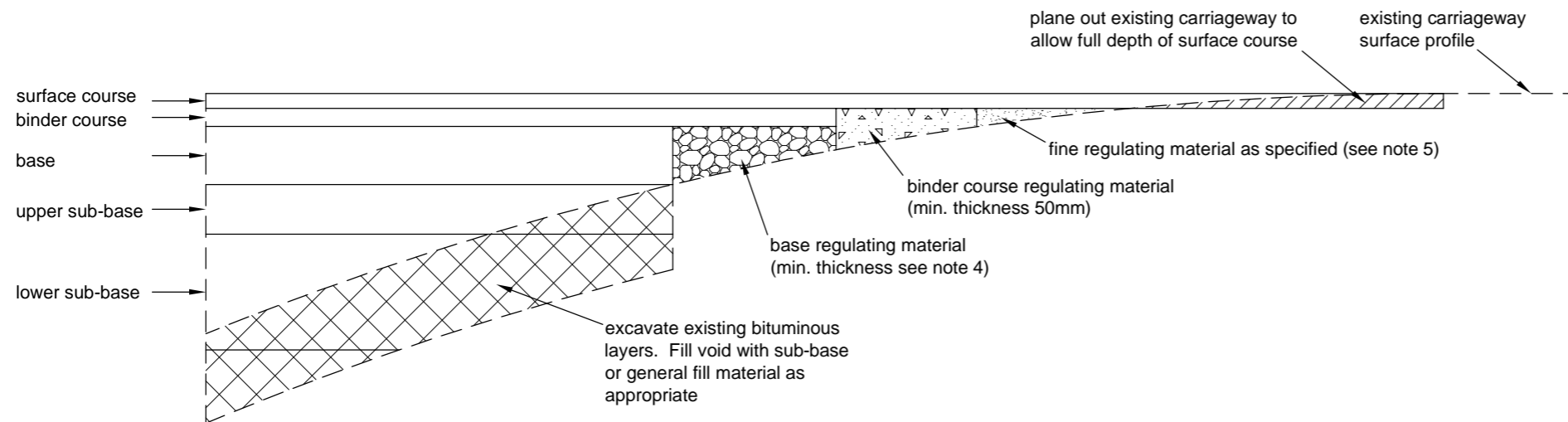

TYPICAL LONGITUDINAL SECTION THROUGH TRANSVERSE JOINT BETWEEN EXISTING CARRIAGEWAY AND NEW CARRIAGEWAY ON FILL

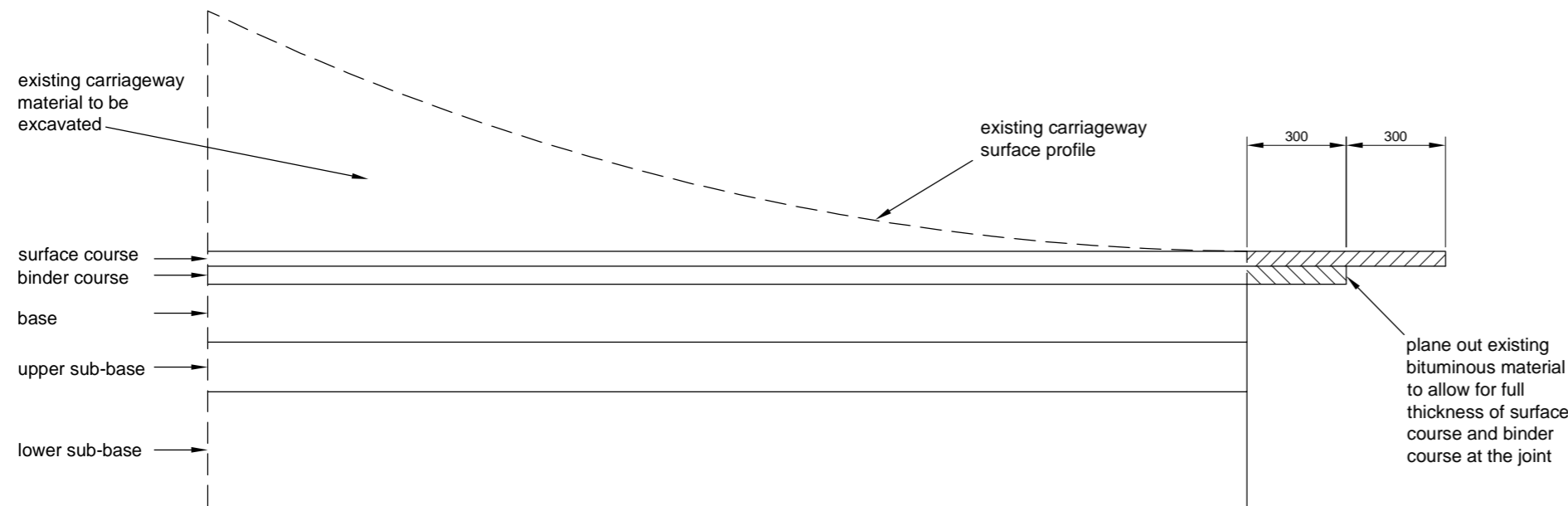

TYPICAL LONGITUDINAL SECTION THROUGH TRANSVERSE JOINT BETWEEN EXISTING CARRIAGEWAY AND NEW CARRIAGEWAY IN CUTTING

NOTES

1. All dimensions are in millimetres unless stated otherwise.
2. 45/6, 45/10, and 55/10F Rolled Asphalt surface courses shall be as specified in the contract, or where no contract specification applies, in accordance with WCC's Surfacing and Structural Maintenance Strategy. All regulating material shall comply with S.H.W. Series 900.
3. Transverse joints in the surface course shall be saw cut.
4. Where 28mm aggregate base is specified, the minimum thickness of base regulating material shall be 70mm. Where 40mm aggregate base is specified, the minimum thickness of base regulating material shall be 90mm.
5. The minimum thickness of fine regulating material shall be 20mm. The remaining void beneath the surface course shall be made up with surface course regulating material just prior to the laying of the full thickness surface course.
6. Sub-base and granular fill material shall not be laid directly onto existing bituminous materials. Affected bituminous layers shall be excavated and the resultant void filled with the appropriate unbound sub-base material.
7. Bond coat to clause 920 shall be applied to all previously trafficked surfaces which are to be overlaid.



HIGHWAY CONSTRUCTION DETAILS

TITLE 1
EDGE OF PAVEMENT DETAILS

TITLE 2
OVERLAY & TRANSVERSE JOINTING DETAILS

| PREVIOUS ISSUES | | ALL DIMENSIONS IN MILLIMETRES UNLESS STATED OTHERWISE | ORIGINAL DRAWING SIZE 420mm x 297mm | |
|-----------------|----------|---|-------------------------------------|---------------------|
| ISSUE | DATE | | DRN | CHKD |
| 1 | FEB 2005 | NOT TO SCALE | RJB | CS |
| 2 | MAY 2010 | DRG NO. | B 705.2 | ISSUE STATUS 3 |
| | | | | ISSUE DATE OCT 2010 |

0mm 50mm 100mm 150mm 200mm

This plot was produced from a digital source so may not be at true scale. It is the recipient's responsibility to confirm its accuracy.

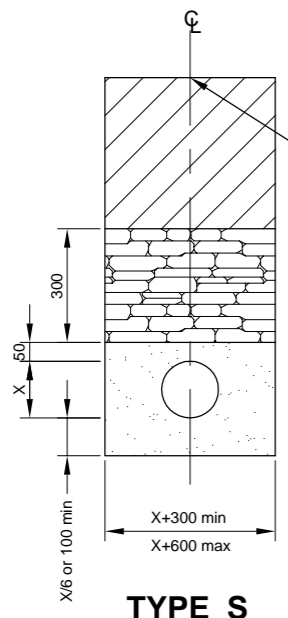

TYPE S

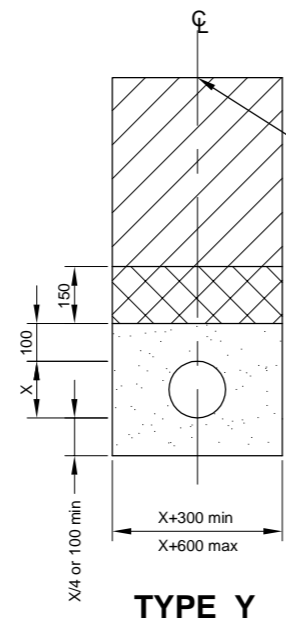

TYPE Y

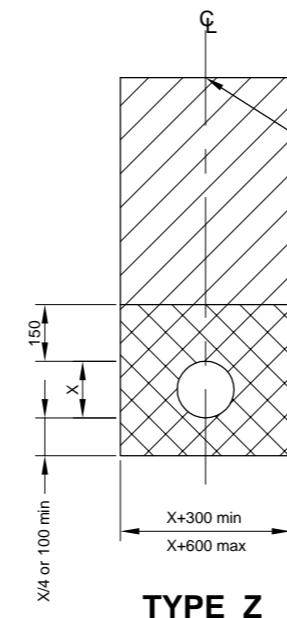

TYPE Z

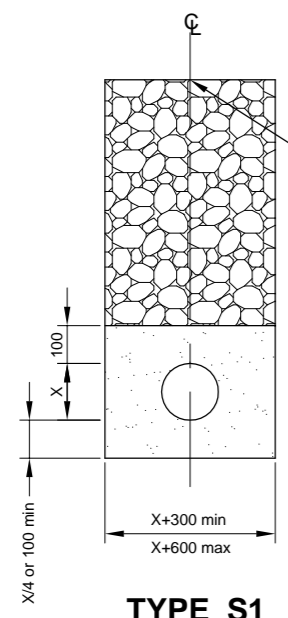

TYPE S1

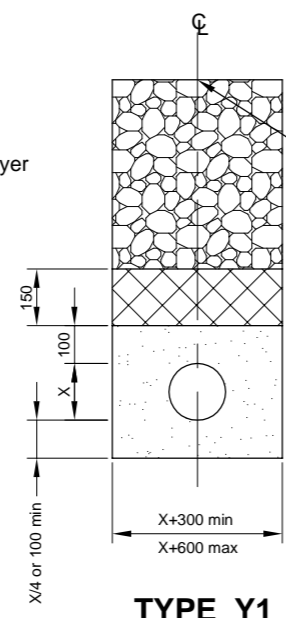

TYPE Y1

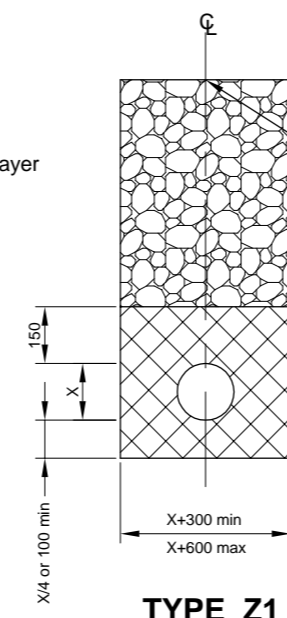





TYPE Z1

NOTES

1. All dimensions are in millimetres unless stated otherwise.
2. Refer to Appendix 5/1 for pipe and bedding alternatives.
3. Dimension 'X' denotes the external diameter of the pipe.
4. The joint detail for pipe surround on Type Z and Z1 drains is for flexible joints only.
5. For pipes with a nominal diameter below 450mm, the thickness of compressible joint filler board shall be 18mm. For pipes with a nominal diameter of 450mm or greater, but not exceeding 1200mm, the thickness of joint filler board shall be 36mm. For pipes exceeding 1200mm nominal diameter, the thickness of joint filler board shall be 54mm.

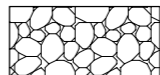
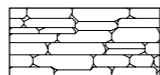
KEY

-  granular material to S.H.W. Clause 503.3(i)
-  concrete to S.H.W. Clause 503.3(iii)
-  granular material Type 1 sub-base to S.H.W. Clause 803 compacted in accordance with Clause 612, table 6/4 method 6
-  Class 8 material to S.H.W. Clause 503.3(iv)
-  general fill material to S.H.W. Clause 505.2

JOINT DETAIL FOR PIPE SURROUND ON TYPE Z AND Z1 DRAINS

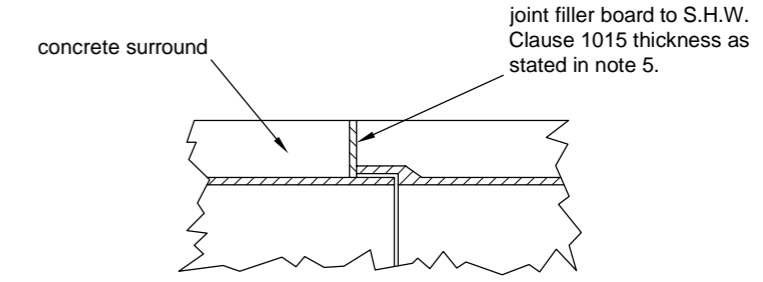

HIGHWAY CONSTRUCTION DETAILS

TITLE 1
DRAINAGE

TITLE 2
SURFACE WATER DRAINS: BEDDING & TRENCH DETAILS

| | | | | |
|-----------------|----------|---|-------------------------------------|------------|
| PREVIOUS ISSUES | | ALL DIMENSIONS IN MILLIMETRES UNLESS STATED OTHERWISE | ORIGINAL DRAWING SIZE 420mm x 297mm | |
| ISSUE | DATE | | DRN | RJB |
| 1 | FEB 2005 | NOT TO SCALE | CHKD | CS |
| DRG NO. F 701.1 | | ISSUE STATUS | 2 | ISSUE DATE |
| | | | | MAY 2010 |

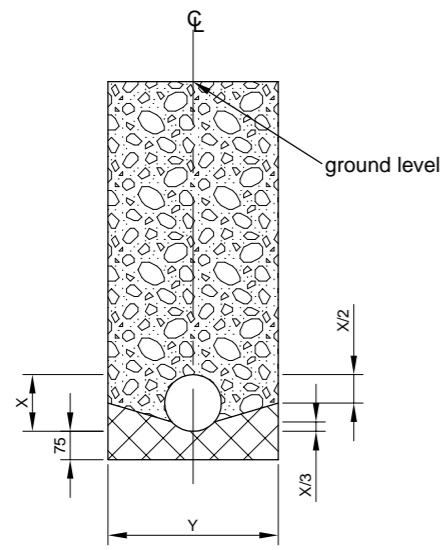

TYPE G

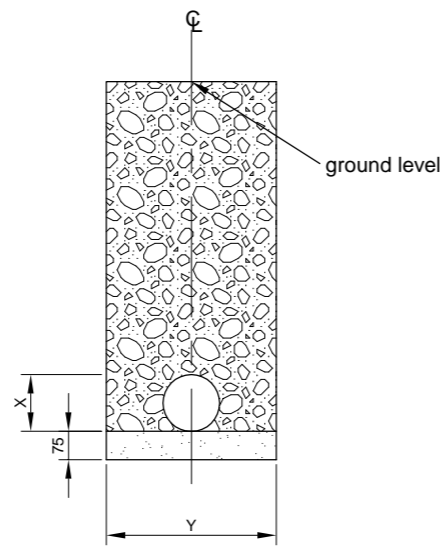

TYPE H

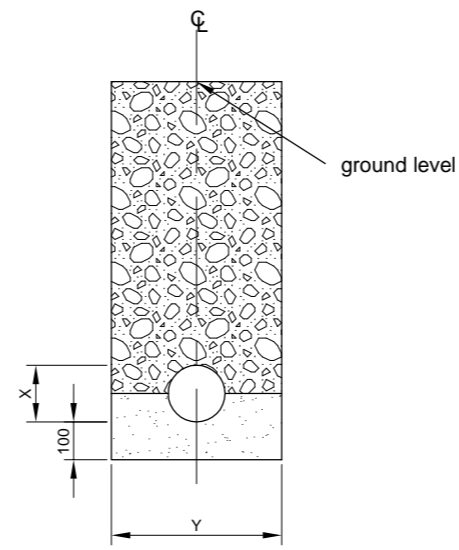

TYPE H1

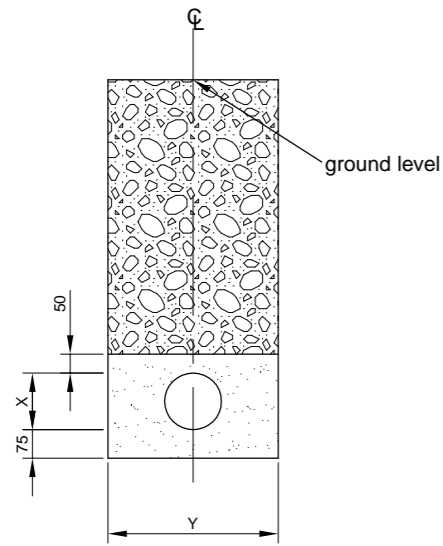

TYPE I

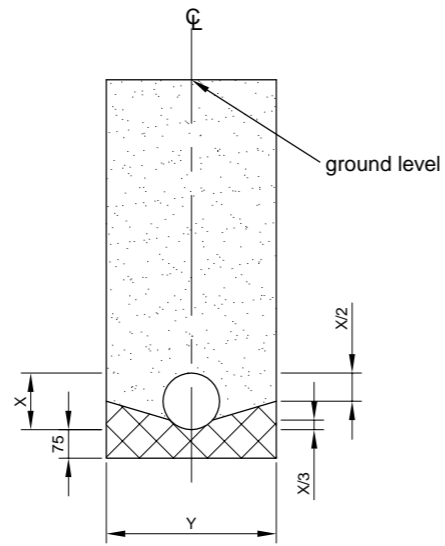

TYPE J

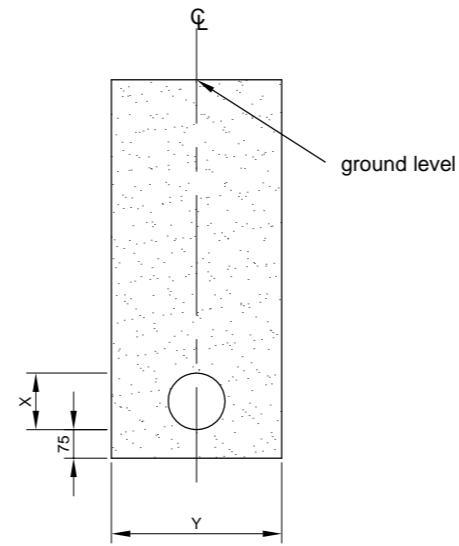

TYPE K

NOTES

1. All dimensions are in millimetres unless stated otherwise.
2. Refer to Appendix 5/1 for pipe and bedding alternatives.
3. Dimension 'X' denotes the external diameter of the pipe.
4. Pipes shall comply with the requirements for filter drain pipes in S.H.W. table 5/1.
5. Pipes shall be laid with the slots or perforations facing upwards.
6. Minimum drain width $Y = X+300$ for drains not exceeding 1.5m cover below finished ground level. $Y = X+450$ for drains exceeding 1.5m cover below finished ground level.

KEY

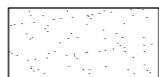
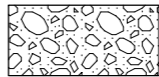
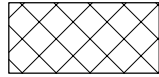
-  Type A or C filter material to S.H.W. Clause 505 or granular material to S.H.W. Clause 503.3(i)
-  Type B filter material to S.H.W. Clause 505.5 table 5/5
-  concrete to S.H.W. Clause 503.3(iii)



**HIGHWAY
CONSTRUCTION
DETAILS**

TITLE 1

DRAINAGE

TITLE 2

**FILTER DRAINS:
BEDDING & TRENCH DETAILS
SHEET 1**

| PREVIOUS ISSUES | | ALL DIMENSIONS IN MILLIMETRES UNLESS STATED OTHERWISE | ORIGINAL DRAWING SIZE 420mm x 297mm | |
|-----------------|----------|---|-------------------------------------|----------------------------|
| ISSUE | DATE | | DRN | CHKD |
| 1 | FEB 2005 | NOT TO SCALE | RJB | CS |
| | | DRG NO. F 702.1 | ISSUE STATUS 2 | ISSUE DATE MAY 2010 |

0mm 50mm 100mm 150mm 200mm

This plot was produced from a digital source so may not be at true scale. It is the recipient's responsibility to confirm its accuracy.

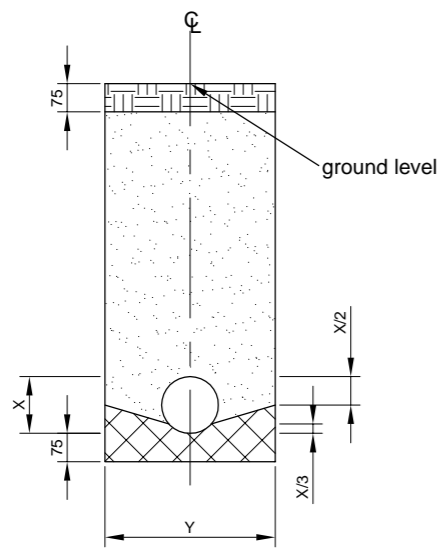

TYPE L

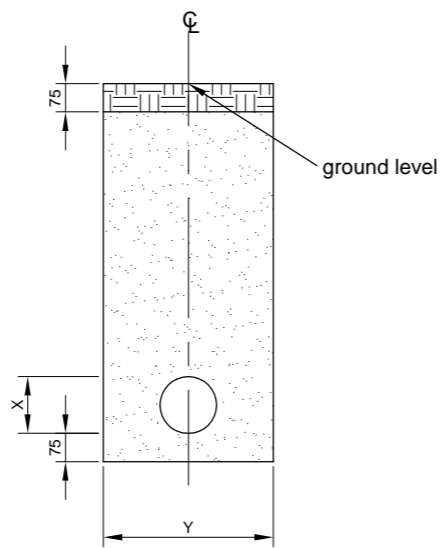

TYPE M

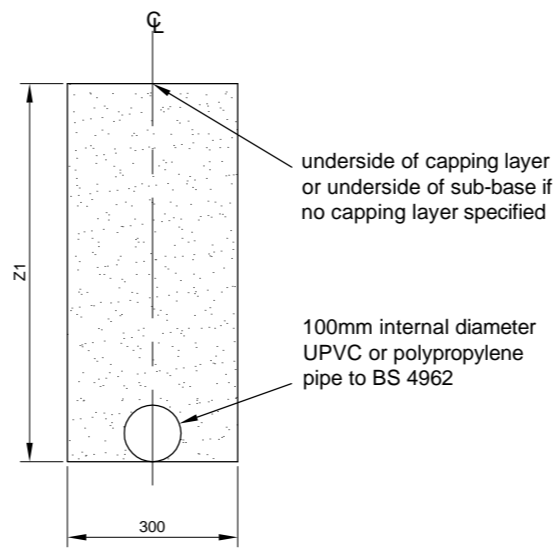

TYPE P (GROUP F7)

NOTES

1. All dimensions are in millimetres unless stated otherwise.
2. Refer to Appendix 5/1 for pipe and bedding alternatives.
3. Dimension 'X' denotes the external diameter of the pipe.
4. Pipes shall comply with the requirements for filter drain pipes in S.H.W. table 5/1.
5. Pipes shall be laid with the slots or perforations facing upwards.
6. Minimum drain width $Y = X+300$ for drains not exceeding 1.5m cover below finished ground level. $Y = X+450$ for drains exceeding 1.5m cover below finished ground level.
7. Depth of Type P filter drain $Z1 =$ capping layer thickness+300mm. Where no capping layer is specified $Z1 = 300$ mm.
8. Depth of Type Q filter drain $Z2 =$ capping layer thickness+(X+50)mm, or 600mm whichever is the greater. Where no capping layer is specified $Z2 = 600$ mm.
9. Group F9B filter drains are the same as Group F9A (shown), except that the filter material shall continue up to ground level.

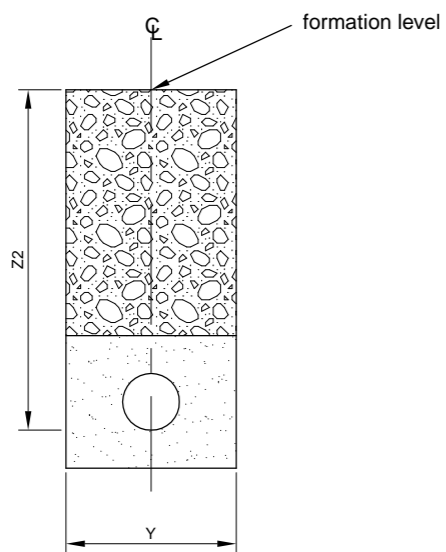

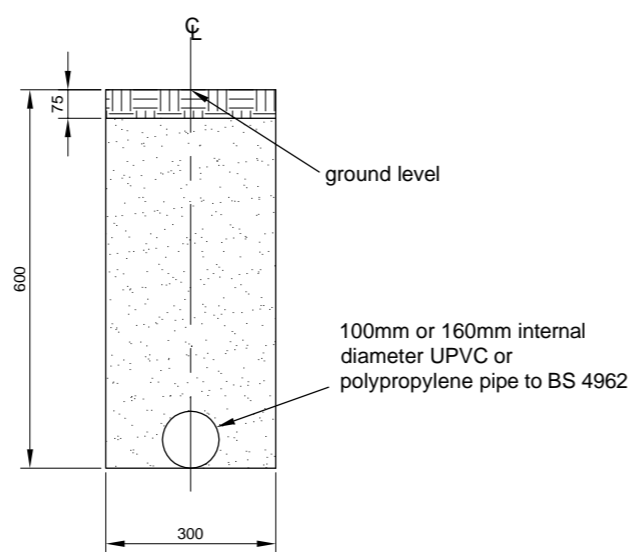

TYPE Q (GROUP F8)

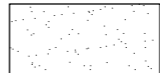
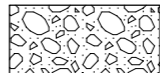

TYPE R (GROUP F9A/F9B)

KEY

-  Type A or C filter material to S.H.W. Clause 505 or granular material to S.H.W. Clause 503.3(i)
-  Type B filter material to S.H.W. Clause 505.5 table 5/5
-  concrete to S.H.W. Clause 503.3(iii)
-  turf or seeded topsoil in accordance with Appendix 5/1



**HIGHWAY
CONSTRUCTION
DETAILS**

TITLE 1
DRAINAGE

TITLE 2
**FILTER DRAINS:
BEDDING & TRENCH DETAILS
SHEET 2**

| PREVIOUS ISSUES | | ALL DIMENSIONS IN MILLIMETRES UNLESS STATED OTHERWISE | ORIGINAL DRAWING SIZE 420mm x 297mm | |
|-----------------|----------|---|-------------------------------------|----------------------------|
| ISSUE | DATE | | DRN | CHKD |
| 1 | FEB 2005 | NOT TO SCALE | RJB | CS |
| | | DRG NO. F 702.2 | ISSUE STATUS 1 | ISSUE DATE MAY 2010 |

0mm 50mm 100mm 150mm 200mm

This plot was produced from a digital source so may not be at true scale. It is the recipient's responsibility to confirm its accuracy.

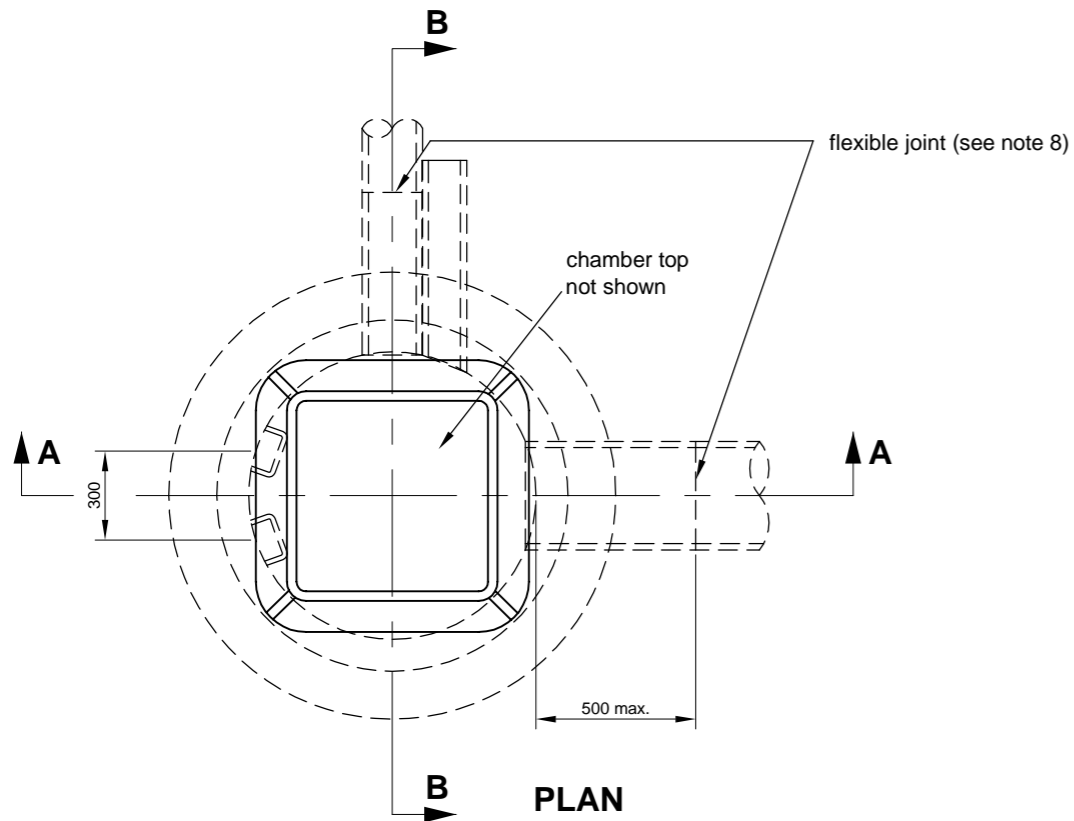
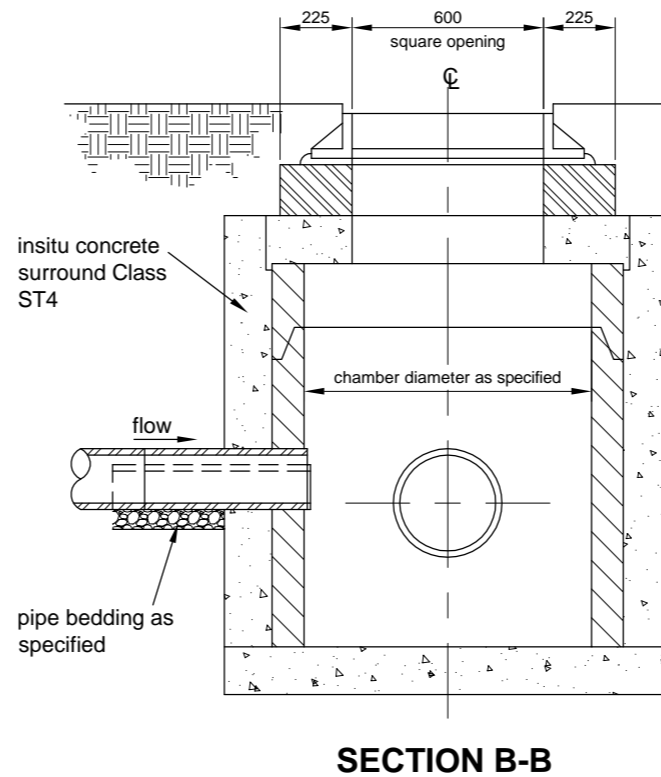
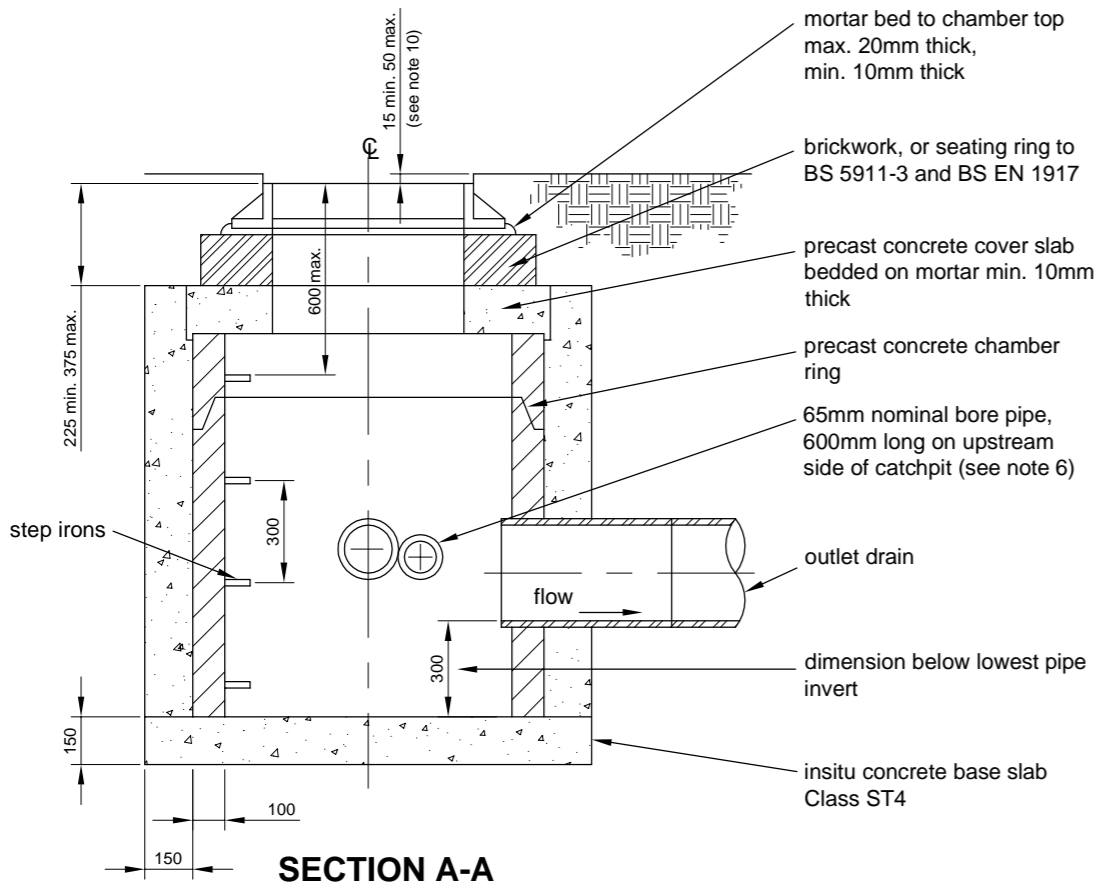

NOTES

- All dimensions are in millimetres unless stated otherwise.
- Precast concrete shall comply with the requirements of BS 5911-3 and BS EN 1917.
- Refer to the scheme specific drawings, Appendix 5/1 and the drainage schedule for invert level, cover level and branch connection details.
- Mortar shall be designation (i) to S.H.W. Clause 2404.
- Pipes shall be grouted into catchpits with mortar.
- 65mm diameter pipes 600mm long shall be built into catchpits to drain the sump of trenches on upstream connections. Pipes shall be positioned above any concrete filter drain beds.
- Both chamber top and step irons shall be positioned so that access will allow persons to face oncoming traffic.
- Flexible joints adjacent to pipe connections shall comply with S.H.W. Clause 507.15.
- Precast concrete catchpit rings shall be of a type manufactured to comprise sulphate resisting cement to BS 4027: 1996.
- The chamber top shall be set as dimensioned below the adjacent:
 - hard shoulder or hardstrip (for verges or central reserves on carriageways without concrete kerbing; and
 - finished ground level in all other off carriageway locations.
 Where catchpits are to be constructed within the carriageway, the chamber top shall be set flush with the carriageway surface.
- Catchpits in new carriageway shall be raised to finished road level following completion of binder course laying and prior to commencement of surface course laying, as prescribed by BS 594987:2007 clause 6.9.
- Brickwork shall be English bond and comprise Class B clay engineering bricks to BS EN 722-3: 1998 and BS EN 722-7: 1998, bedded on mortar. Brickwork shall comply with S.H.W. Clauses 2406 and 2412.
- This detail applies only to those catchpits where the distance between cover level and catchpit invert level does not exceed 2.0m.
- Type 71 catchpits are as shown. Type 72 catchpits are as shown but without the 150mm in-situ concrete surround.

| Chamber Type | Chamber Diameter (mm) | Base Slab Diameter (mm) |
|--------------|-----------------------|-------------------------|
| 71A & 72A | 900 | 1400 |
| 71B & 72B | 1050 | 1550 |
| 71C & 72C | 1200 | 1700 |
| 71D & 72D | 1350 | 1850 |
| 71E & 72E | 1500 | 2000 |

| Chamber Type | Chamber Length (mm) | Chamber Depth (mm) |
|--------------|---------------------|--------------------|
| 73A | 900 | not exceeding 1500 |
| 73B | 1200 | 1500 - 2500 |

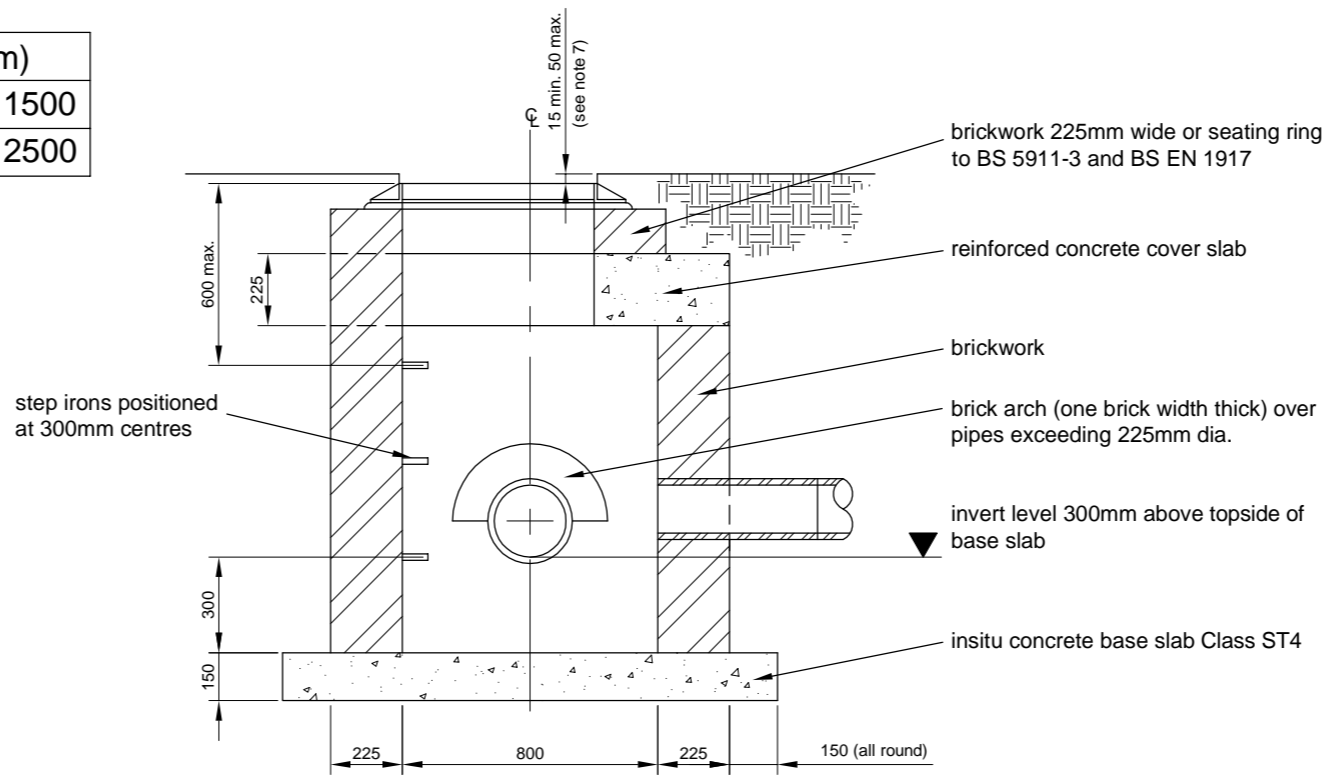

SECTION A-A

NOTES

- All dimensions are in millimetres unless stated otherwise.
- Refer to the scheme specific drawings, Appendix 5/1 and the drainage schedule for invert level, cover level and branch connection details.
- Mortar shall be designation (i) to S.H.W. Clause 2404.
- Pipes shall be grouted into catchpits with mortar.
- Both chamber top and step irons shall be positioned so that access will allow persons to face oncoming traffic.
- Flexible joints adjacent to pipe connections shall comply with S.H.W. Clause 507.15.
- The chamber top shall be set as dimensioned below the adjacent:
 - hard shoulder or hardstrip (for verges or central reserves on carriageways without concrete kerbing; and
 - finished ground level in all other locations.
 Where catchpits are to be constructed within the carriageway, the chamber top shall be set flush with the carriageway surface.
- Catchpits in new carriageway shall be raised to finished road level following completion of binder course laying and prior to commencement of surface course laying, as prescribed by BS 4987: Part 2 Clause 5.8.
- Brickwork shall be English bond and comprise Class B clay engineering bricks to BS EN 771-1:2003, bedded on mortar. Brickwork shall comply with S.H.W. Clauses 2406 and 2412.
- This detail applies only to those catchpits where the distance between cover level and catchpit invert level does not exceed 2.0m.
- On reinforced concrete cover slabs:
 - reinforcement shall be positioned in the tension zone (bottom of slab) only;
 - concrete shall be grade 40/20, minimum cement content = 325kg/m³, maximum water/cement ratio = 0.5;
 - reinforcement cover shall be 45mm;
 - reinforcement steel bars shall be grade 460 to BS 4449:2005+A2:2009; and
 - reinforcement steel bars shall be hooked at the ends in accordance with BS 8666: 2005 and BS EN ISO 4066: 2000.

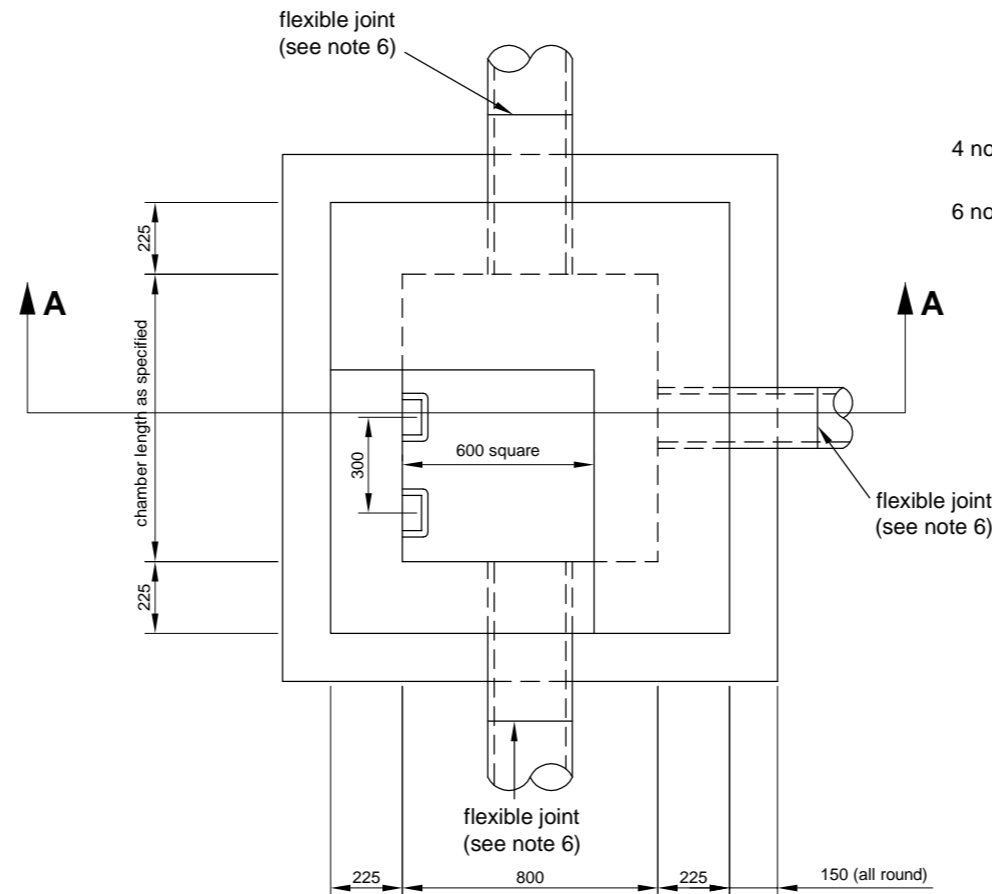

PLAN

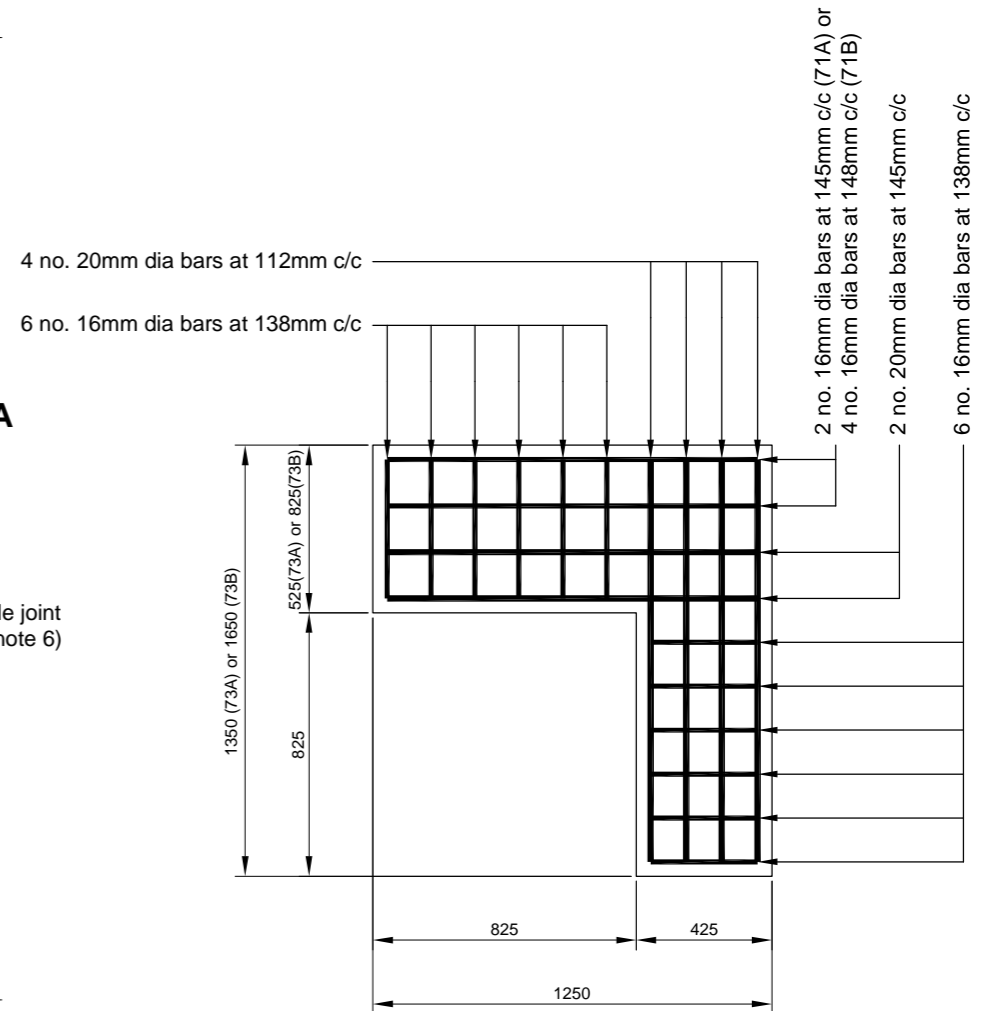

COVER SLAB AND REINFORCEMENT DETAIL

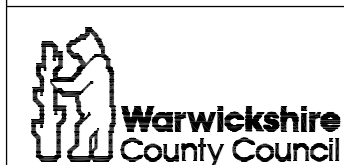

**HIGHWAY
CONSTRUCTION
DETAILS**

TITLE 1
DRAINAGE

TITLE 2
**BRICK CATCHPIT:
TYPE 73**

| PREVIOUS ISSUES | | ALL DIMENSIONS IN MILLIMETRES UNLESS STATED OTHERWISE | ORIGINAL DRAWING SIZE 420mm x 297mm | |
|-----------------|----------|---|-------------------------------------|---------|
| ISSUE | DATE | | DRN | RJB |
| 1 | FEB 2005 | NOT TO SCALE | | CHKD CS |
| DRG NO. F 703.2 | | ISSUE STATUS 2 | ISSUE DATE MAY 2010 | |

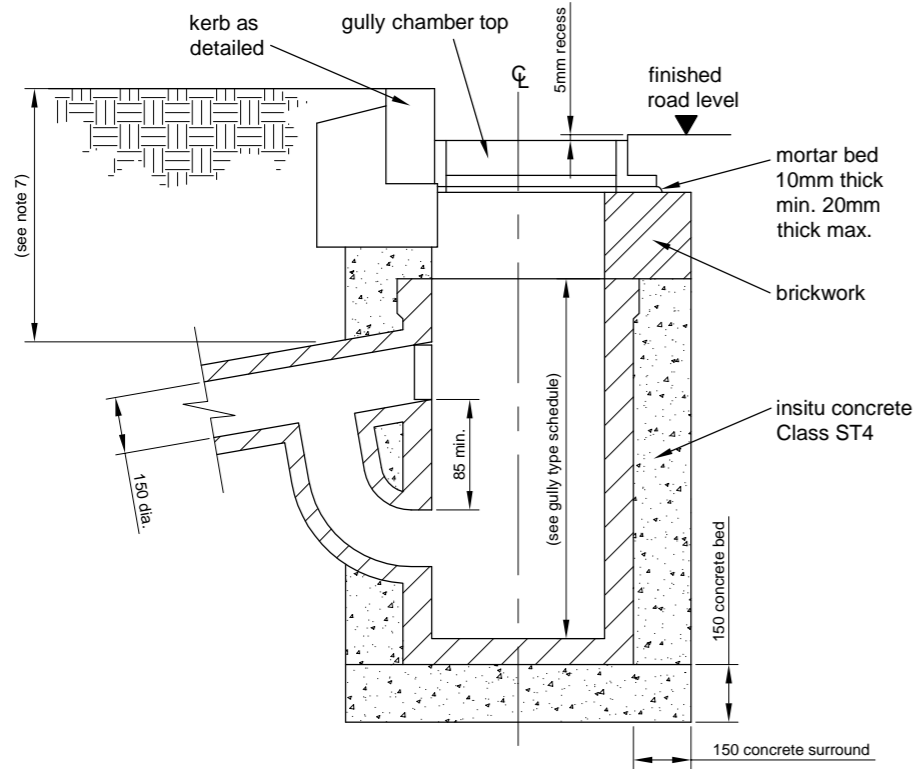

PRE-CAST CONCRETE CHANNEL GULLY

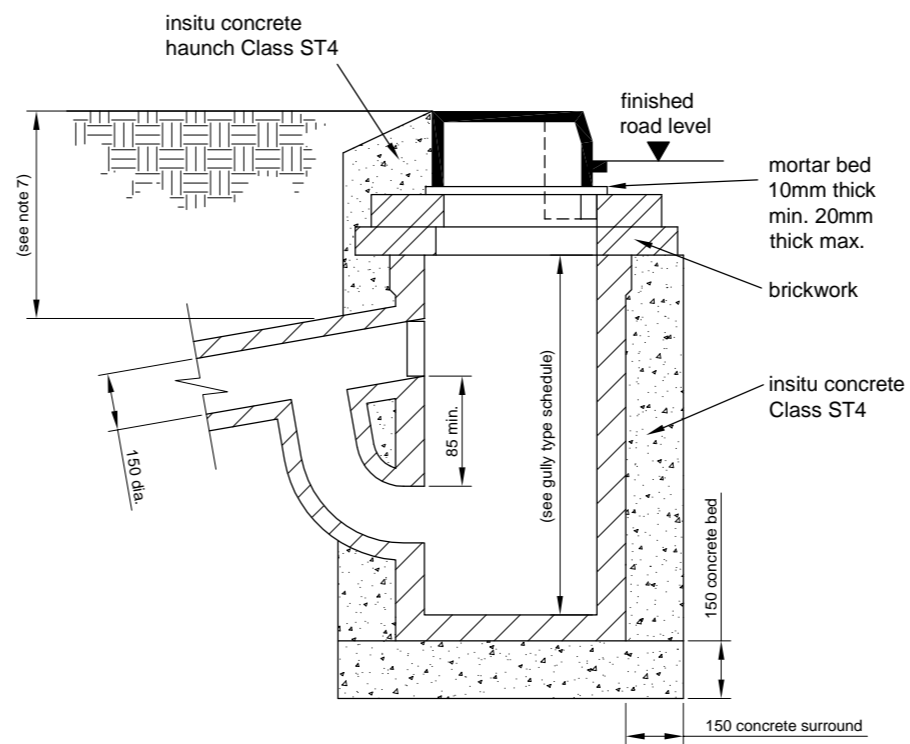

PRE-CAST CONCRETE KERB INLET GULLY

NOTES

1. All dimensions are in millimetres unless stated otherwise.
2. Channel gully chamber top shall be grade D400 (BS EN 124). Kerb inlet gully chamber top shall be grade GK-165 unless otherwise specified in the contract documents.
3. Precast concrete gullies shall comply with BS 5911: 2002/2004.
4. Channel gullies shall be raised to finished road level following completion of binder course laying and prior to commencement of surface course laying, as prescribed by BS 594987:2007 clause 6.9.
5. Brickwork shall be English bond and comprise Class B clay engineering bricks to BS EN 771-1:2003, bedded on mortar. Brickwork shall comply with S.H.W. Clauses 2406 and 2412. Brickwork may require corbelling depending on the type of pot and frame.
6. Mortar shall comply with S.H.W. Clause 2404 designation (i).
7. The minimum depth from the top of kerb (on channel gullies) or over level (on kerb inlet gullies) to the soffit level of the gully outlet shall be 750mm when the connecting pipe is below carriageway (or hardshoulder), and 600mm elsewhere.
8. The stoppers on trapped insitu cast gullies shall comply with the requirements of BS 5911: 2002/2004
9. Gully connections under carriageway shall comply with the requirements of either Pipe Group S7 or S8 depending on depth of cover. Gully connections within 4m of the carriageway shall comply with the requirements of Pipe Group S2. Gully connections in all other locations shall comply with the requirements of Pipe Group S3. Refer to Notes for Guidance Annex 1, or Appendix 5/1 for pipe group details.
10. Refer to the schedule below for gully types.
11. Plastic gullies with insitu-cast concrete surrounds may be used for channel gullies (as shown), or for kerb inlet gullies.

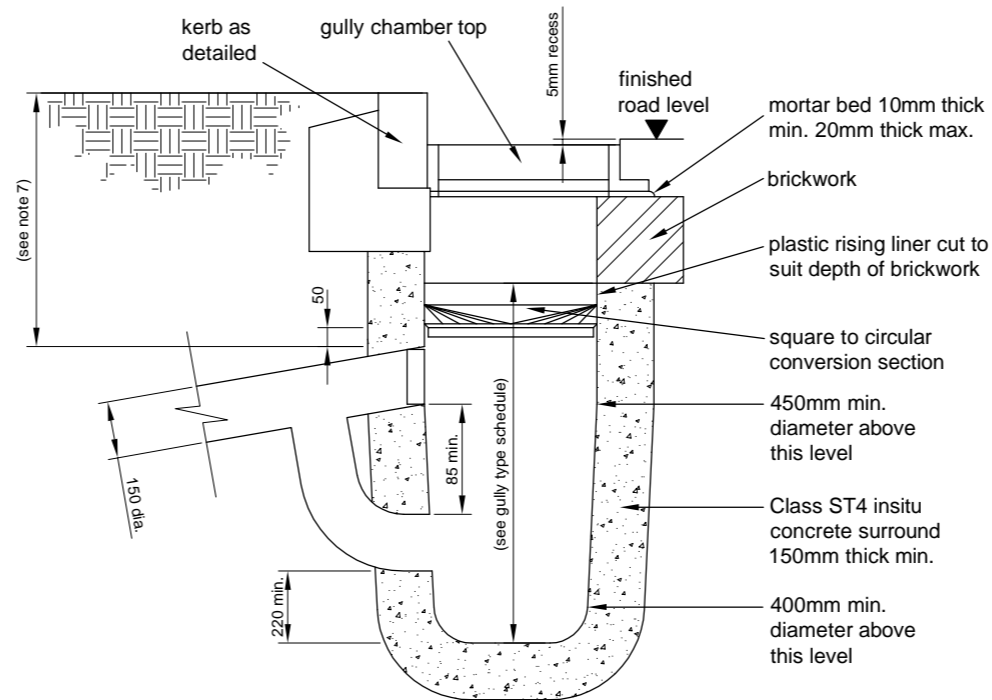
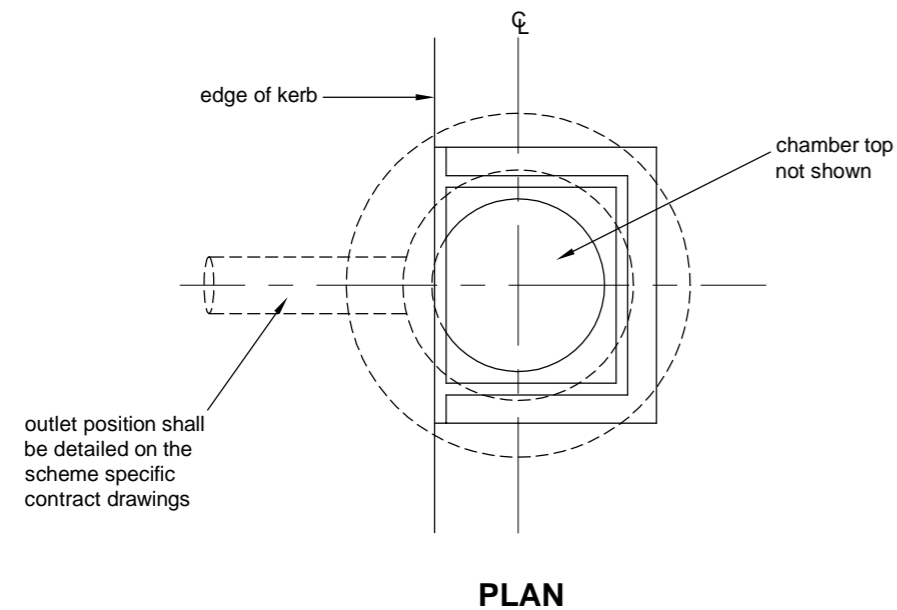

PLASTIC GULLY WITH INSITU-CAST CONCRETE SURROUND

| GULLY TYPE | 1 | 2A | 2B |
|-------------------------|-----|-----|-----|
| INTERNAL DIAMETER (mm) | 450 | 375 | 375 |
| DEPTH OF GULLY POT (mm) | 900 | 750 | 900 |



HIGHWAY CONSTRUCTION DETAILS

TITLE 1
DRAINAGE

TITLE 2
GULLIES: TYPES 1, 2A, & 2B

| PREVIOUS ISSUES | | ALL DIMENSIONS IN MILLIMETRES UNLESS STATED OTHERWISE | ORIGINAL DRAWING SIZE 420mm x 297mm | |
|-----------------|----------|---|-------------------------------------|----------------|
| ISSUE | DATE | | DRN | RJB |
| 1 | FEB 2005 | NOT TO SCALE | DRN | RJB |
| | | DRG NO. F 704.1 | ISSUE STATUS 2 | CHKD CS |
| | | ISSUE DATE MAY 2010 | | |

0mm 50mm 100mm 150mm 200mm This plot was produced from a digital source so may not be at true scale. It is the recipient's responsibility to confirm its accuracy.

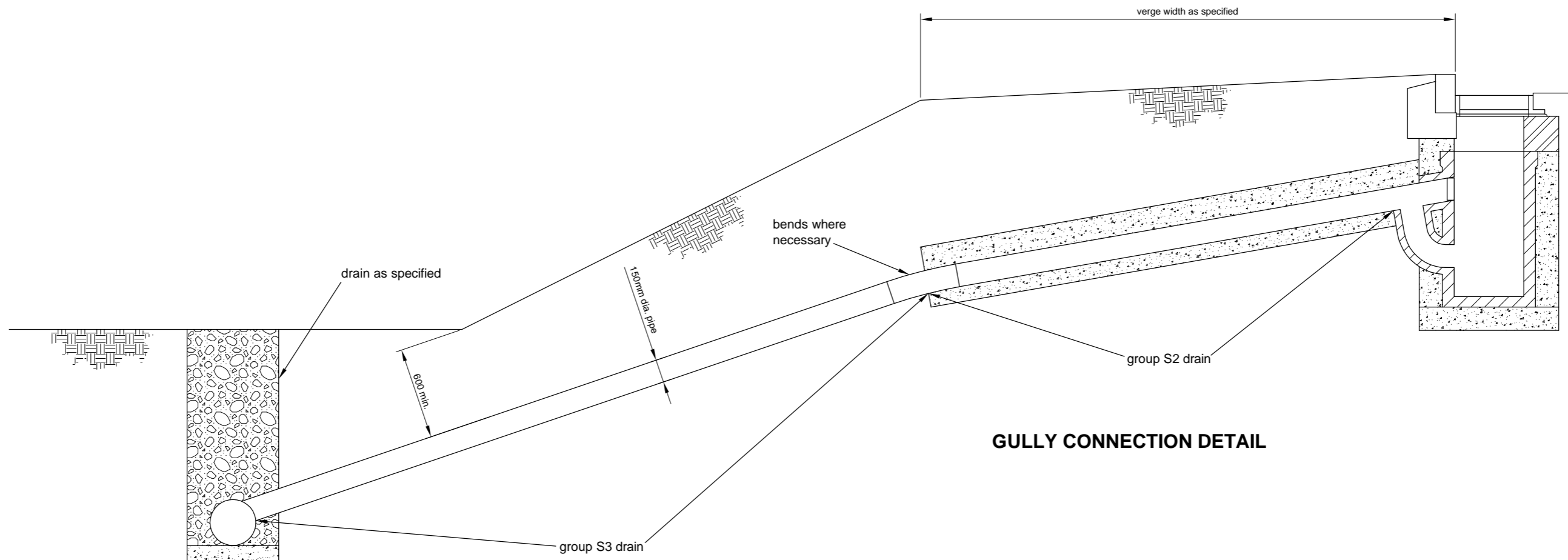

GULLY CONNECTION DETAIL

NOTES

1. All dimensions are in millimetres unless stated otherwise.
2. Where gullies discharge into an open ditch, a Type 5 headwall shall be constructed at the outfall. Refer to F 705.2 for details.
3. Mortar shall comply with S.H.W. Clause 2404 designation (i).

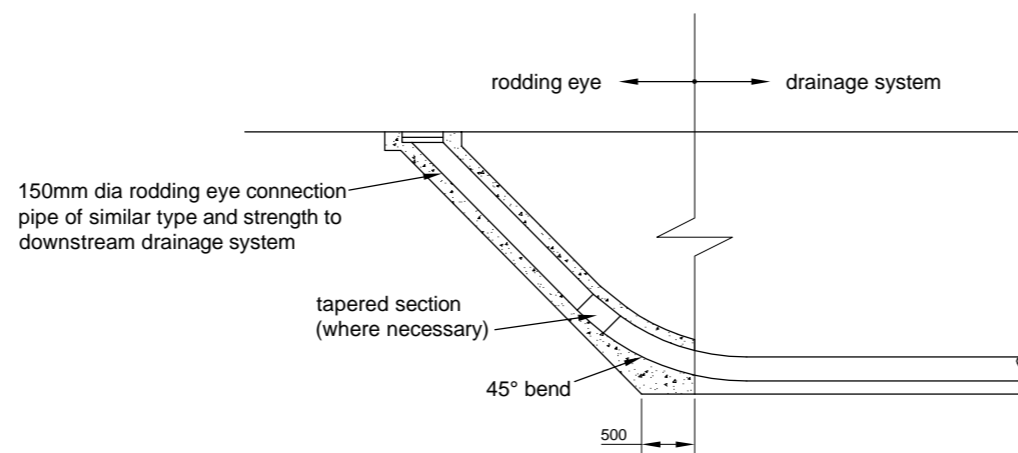

RODDING EYE DETAIL

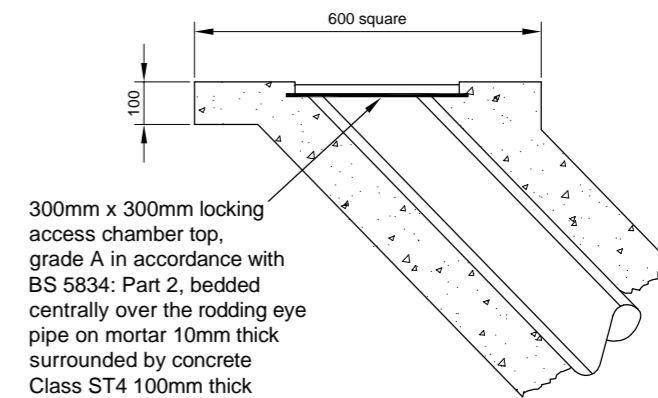

RODDING EYE COVER DETAIL



**HIGHWAY
CONSTRUCTION
DETAILS**

| | |
|---------|----------|
| TITLE 1 | DRAINAGE |
|---------|----------|

| | |
|---------|-------------------------------------|
| TITLE 2 | GULLY CONNECTIONS & RODDING EYES |
|---------|-------------------------------------|

| | | | | | |
|-----------------|----------|---|-------------------------------------|------------|----------|
| PREVIOUS ISSUES | | ALL DIMENSIONS IN MILLIMETRES UNLESS STATED OTHERWISE | ORIGINAL DRAWING SIZE 420mm x 297mm | | |
| ISSUE | DATE | | | CHKD | CS |
| 1 | FEB 2005 | NOT TO SCALE | DRN | RJB | |
| | | DRG NO. F 704.2 | ISSUE STATUS 2 | ISSUE DATE | MAY 2010 |

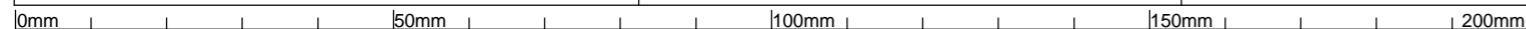

This plot was produced from a digital source so may not be at true scale. It is the recipient's responsibility to confirm its accuracy.

TYPE 1 HEADWALL

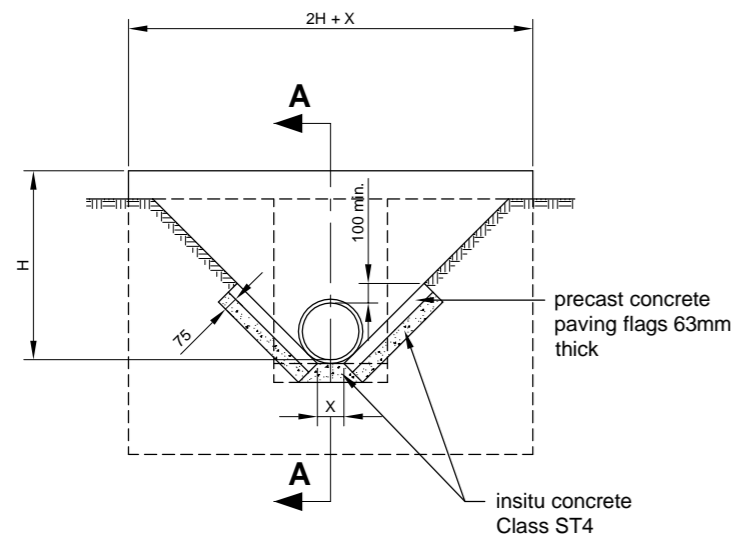

ELEVATION

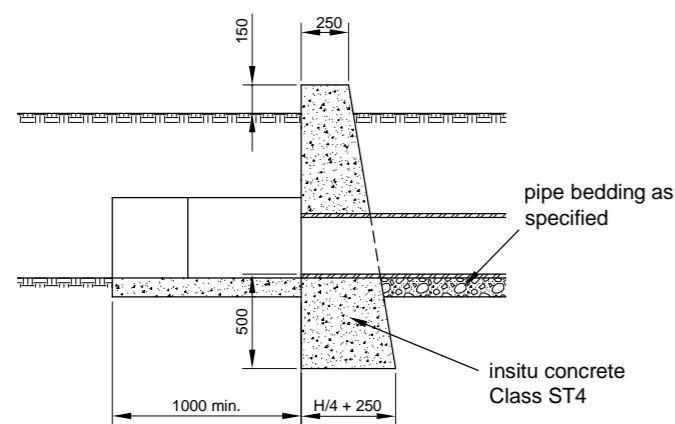

SECTION A-A

TYPE 2 HEADWALL

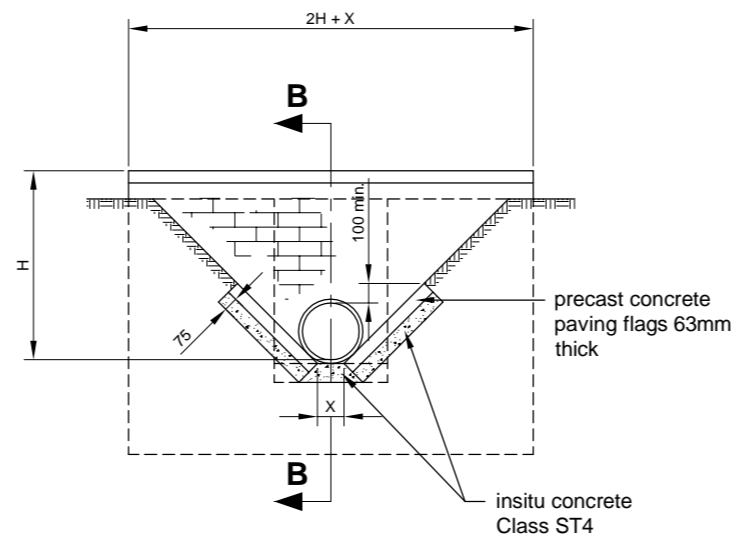

ELEVATION

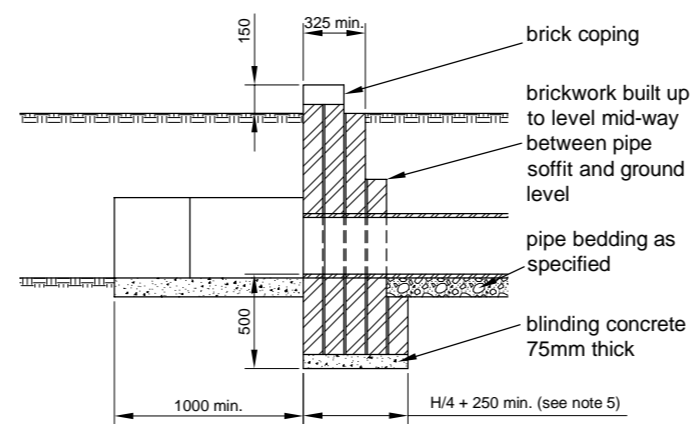

SECTION B-B

TYPE 3 HEADWALL

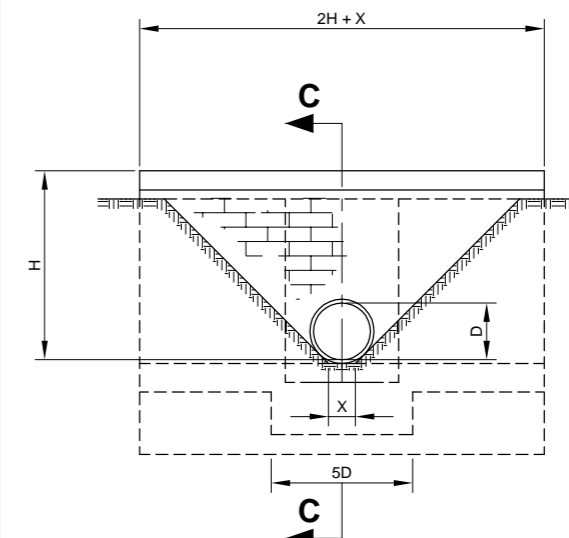

ELEVATION

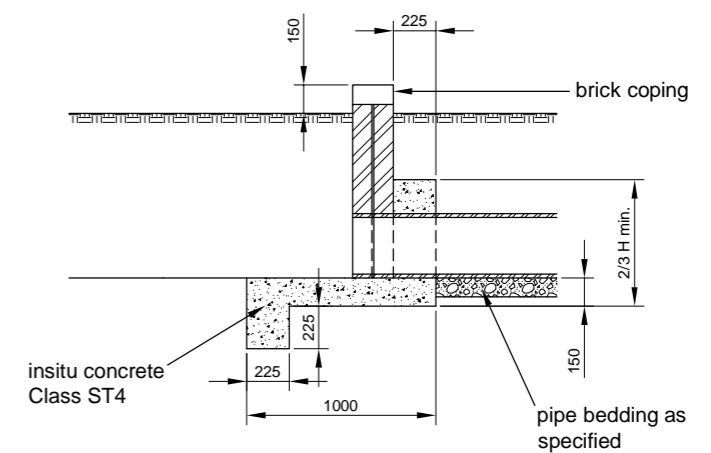

SECTION C-C

NOTES

- All dimensions are in millimetres unless stated otherwise.
- Headwall dimensions:
 - H = height of headwall from outfall invert level to top of parapet;
 - X = width of ditch invert; and
 - D = internal diameter of pipe.
- Refer to F 705.2 for ditch lining details.
- Refer to drainage schedule in Appendix 5/1 or scheme specific contract drawings for pipe diameter and ditch side slope gradient.
- The base on Type 2 headwalls shall be finished to the nearest complete brick width above the minimum dimension stated.
- The maximum height 'H' and pipe diameter 'D' on Type 3 Headwalls shall be 1000mm and 300mm respectively.
- Concrete finishes shall comply with S.H.W. Clause 2602
- Brickwork shall be English bond and comprise Class B clay engineering bricks to BS EN 771-1:2003, bedded on mortar. Brickwork shall comply with S.H.W. Clauses 2406 and 2412.
- Mortar shall comply with S.H.W. Clause 2404 designation (i).
- The nearest pipe joint on pipes where diameter 'D' is greater than 375mm shall be no more than 1m from the outer face of the headwall.



HIGHWAY
CONSTRUCTION
DETAILS

TITLE 1

DRAINAGE

TITLE 2

HEADWALLS:
TYPES 1, 2 & 3

| PREVIOUS ISSUES | | ALL DIMENSIONS IN MILLIMETRES UNLESS STATED OTHERWISE | ORIGINAL DRAWING SIZE 420mm x 297mm | |
|-----------------|----------|---|-------------------------------------|----------|
| ISSUE | DATE | | DRN | RJB |
| 1 | FEB 2005 | NOT TO SCALE | DRN | RJB |
| | | DRG NO. F 705.1 | ISSUE STATUS 2 | CHKD CS |
| | | | ISSUE DATE | MAY 2010 |

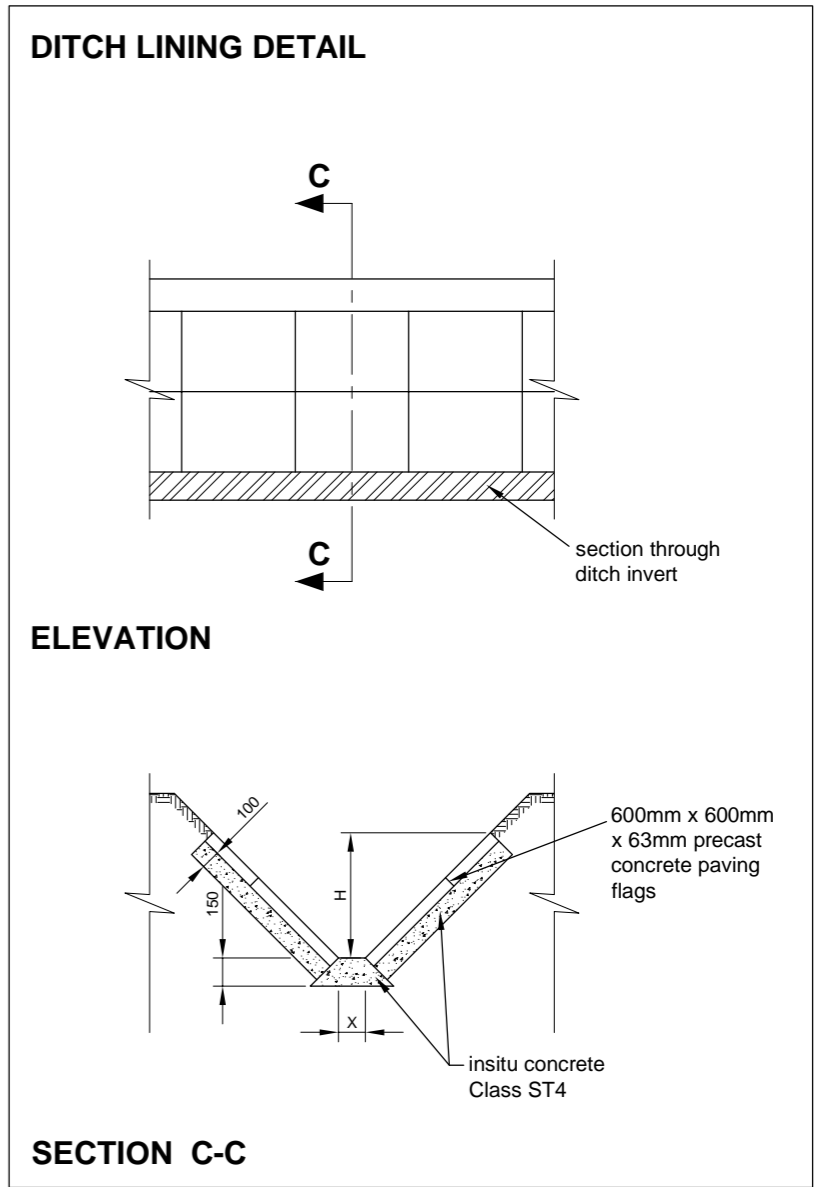
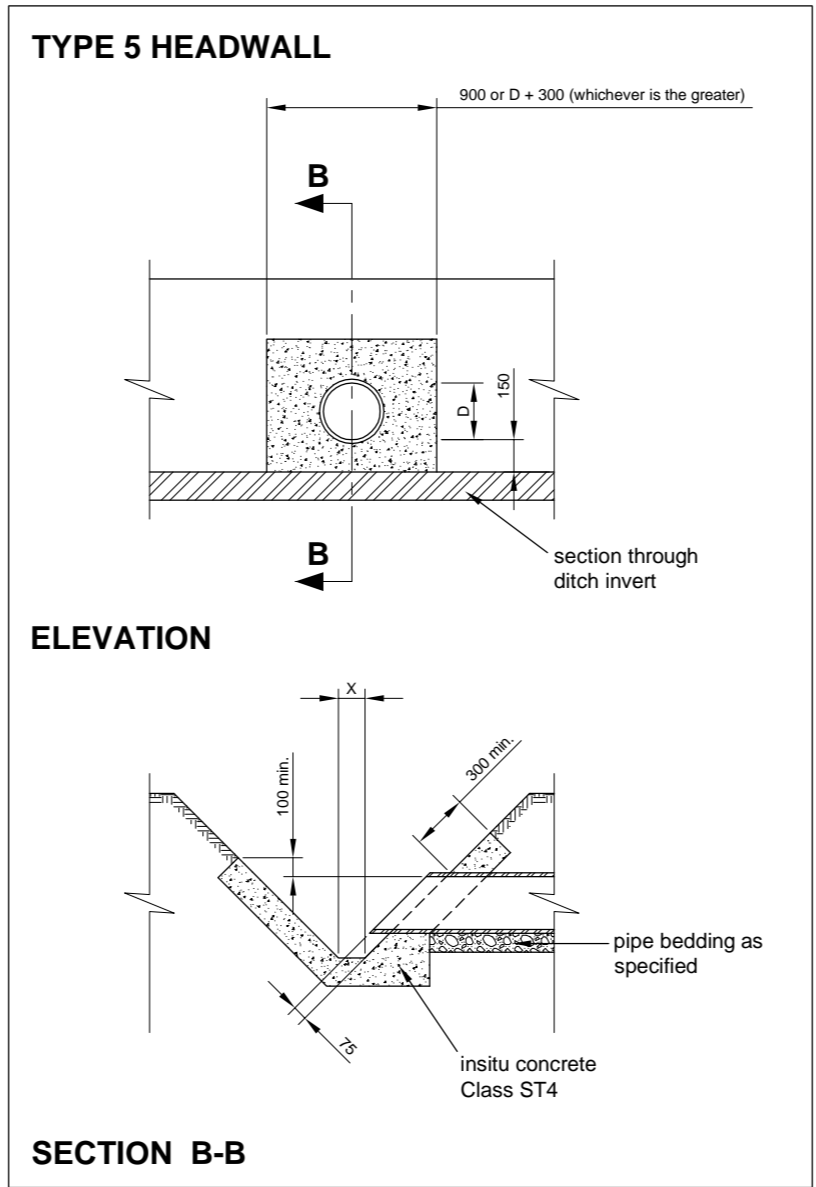
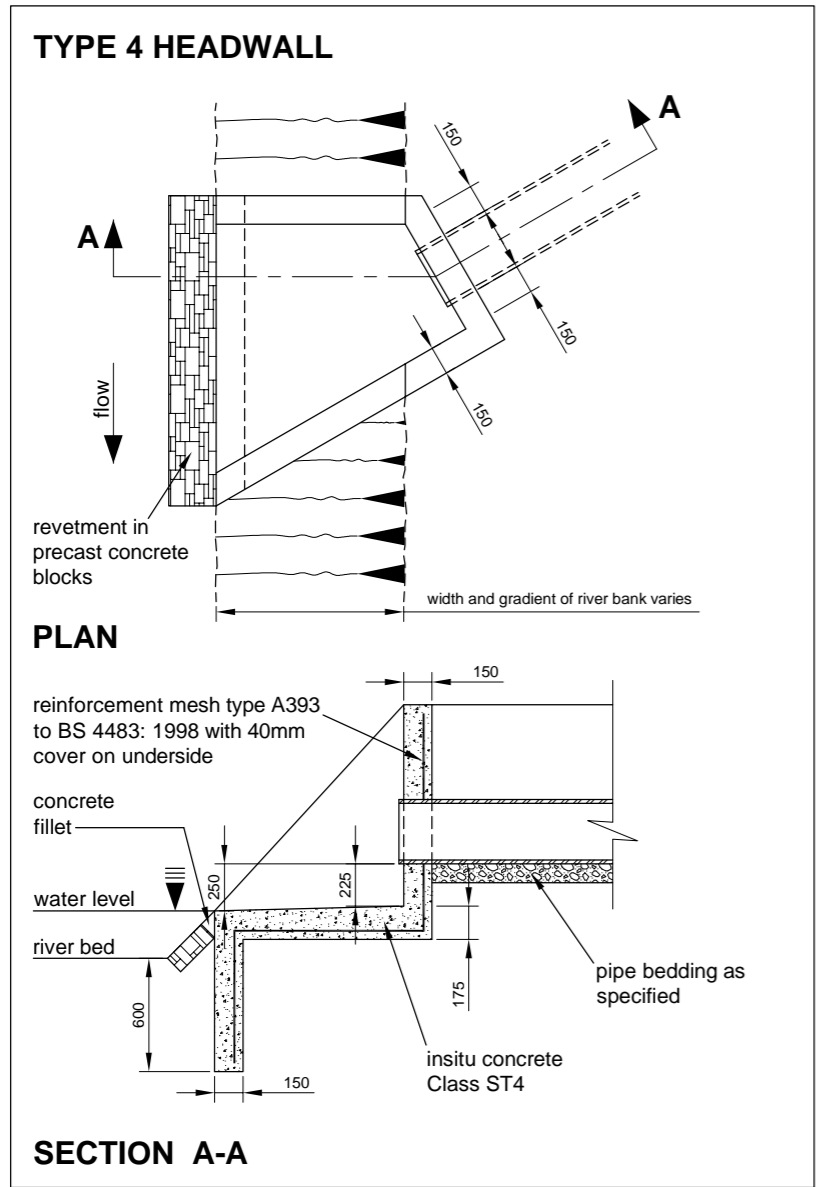

NOTES

- All dimensions are in millimetres unless stated otherwise.
- Headwall and ditch lining dimensions:
 - H = height of ditch lining from ditch invert level,
 - X = width of ditch invert, and
 - D = internal diameter of pipe.
- Refer to drainage schedule in Appendix 5/1 or scheme specific contract drawings for pipe diameter and ditch side slope gradient.
- Precast concrete paving flags shall comply with BS EN 1339:2005.
- Concrete finishes shall comply with S.H.W. Clause 2602
- Brickwork shall be English bond and comprise Class B clay engineering bricks to BS EN 771-1:2003, bedded on mortar. Brickwork shall comply with S.H.W. Clauses 2406 and 2412.
- Mortar shall comply with S.H.W. Clause 2404 designation (i).
- The nearest pipe joint on pipes where diameter 'D' is greater than 375mm shall be no more than 1m from the outer face of the headwall.
- On Type 4 headwalls, the angle between outfall pipe and direction of flow on the watercourse shall be 45° unless otherwise directed by the Overseeing Organisation.
- Environment agency approval is required where Type 4 headwalls discharge into natural watercourses.



**HIGHWAY
CONSTRUCTION
DETAILS**

TITLE 1
DRAINAGE

TITLE 2
**HEADWALLS: TYPES 4 & 5
& DITCH LINING DETAIL**

| PREVIOUS ISSUES | | ALL DIMENSIONS IN MILLIMETRES UNLESS STATED OTHERWISE | ORIGINAL DRAWING SIZE 420mm x 297mm | |
|-----------------|----------|---|-------------------------------------|----------------------------|
| ISSUE | DATE | | DRN | CHKD |
| 1 | FEB 2005 | NOT TO SCALE | RJB | CS |
| | | DRG NO. F 705.2 | ISSUE STATUS 2 | ISSUE DATE MAY 2010 |

CONNECTION OF EXISTING LAND DRAIN TO NEW FILTER DRAIN

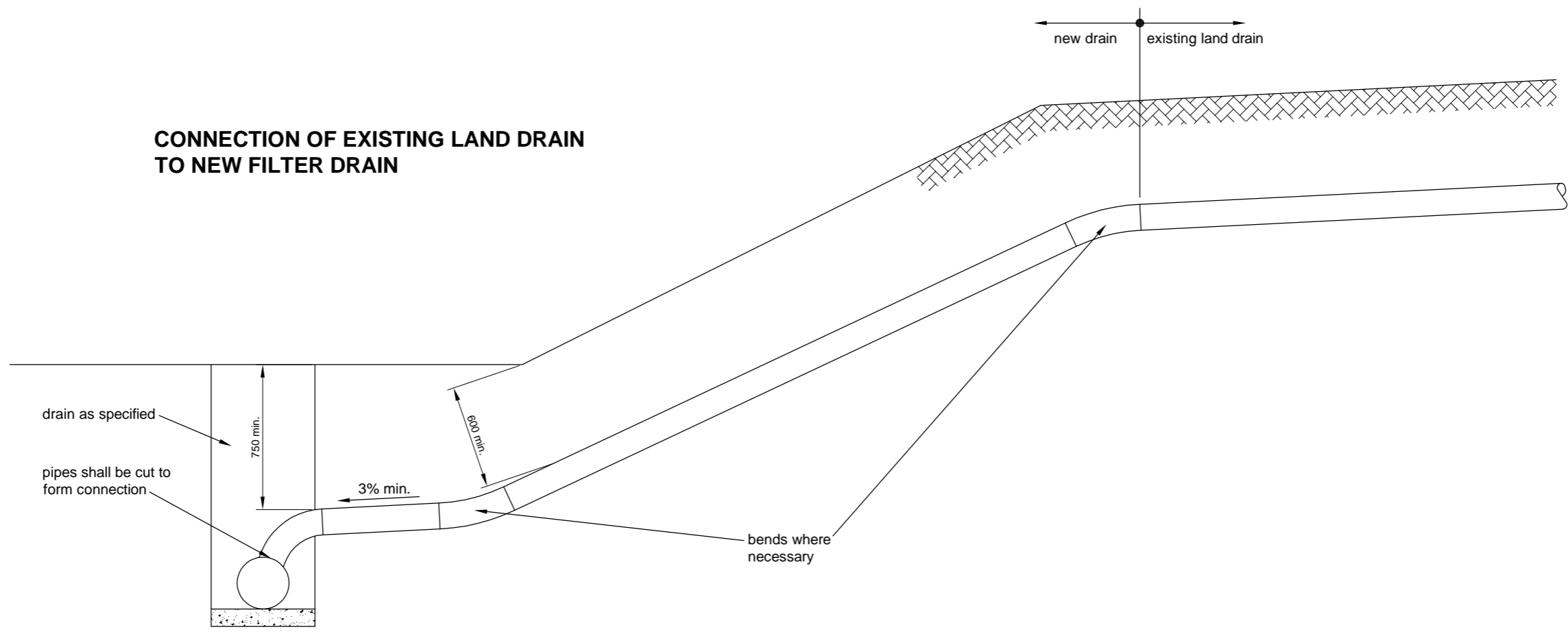

NOTES

1. All dimensions are in millimetres unless stated otherwise.
2. Jointed perforated or slotted pipes (UPVC, concrete or vitrified clay) may be used as an alternative.
3. Pipe haunches and surrounds shall comply with S.H.W. Clause 503.3 (v).
4. The internal diameter of new pipes downstream of the connection point shall be no less than the internal diameter of the existing land drain.
5. Pipes shall be laid with open joints and bedded on the bottom of the trench. Backfill shall be Class 1, 2A, 2B or 2C material in accordance with S.H.W. Table 6/1 overlaid with topsoil as specified.

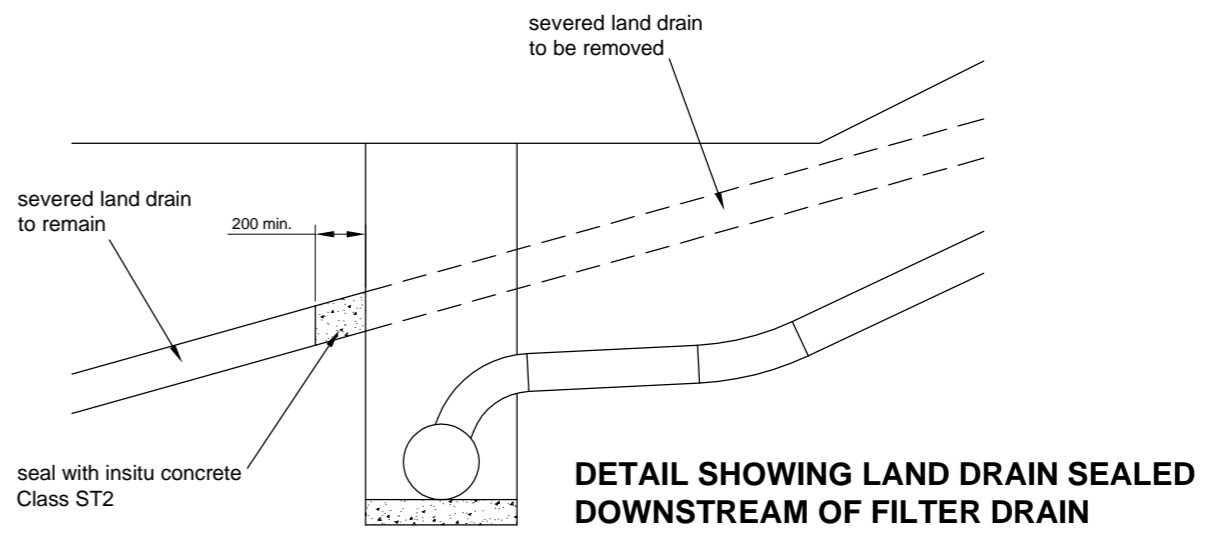

**HIGHWAY
CONSTRUCTION
DETAILS**

TITLE 1
DRAINAGE

TITLE 2
**CONNECTION OF PERMANENTLY
SEVERED LAND DRAINS**

| PREVIOUS ISSUES | | ALL DIMENSIONS IN MILLIMETRES UNLESS STATED OTHERWISE | ORIGINAL DRAWING SIZE 420mm x 297mm | |
|-----------------|----------|---|-------------------------------------|----------------------------|
| ISSUE | DATE | | DRN | CHKD |
| 1 | FEB 2005 | NOT TO SCALE | RJB | CS |
| | | DRG NO. F 706.1 | ISSUE STATUS 2 | ISSUE DATE MAY 2010 |

0mm 50mm 100mm 150mm 200mm

This plot was produced from a digital source so may not be at true scale. It is the recipient's responsibility to confirm its accuracy.

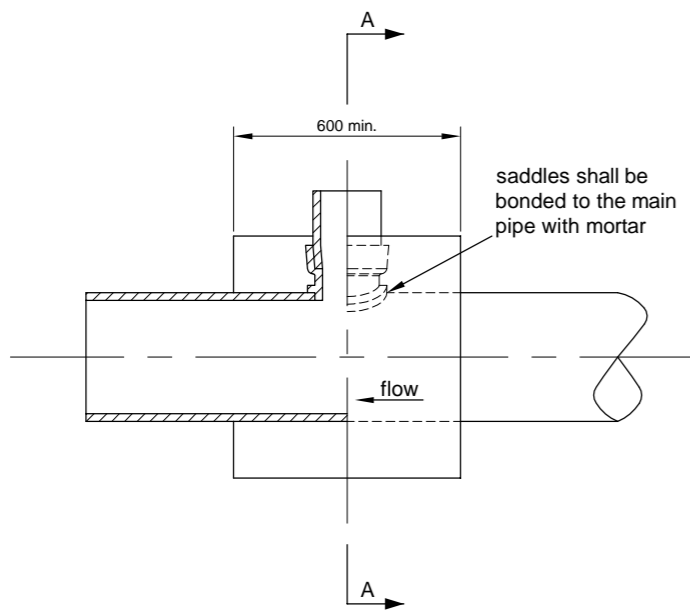

**ELEVATION/SECTION
(SQUARE SADDLE)**

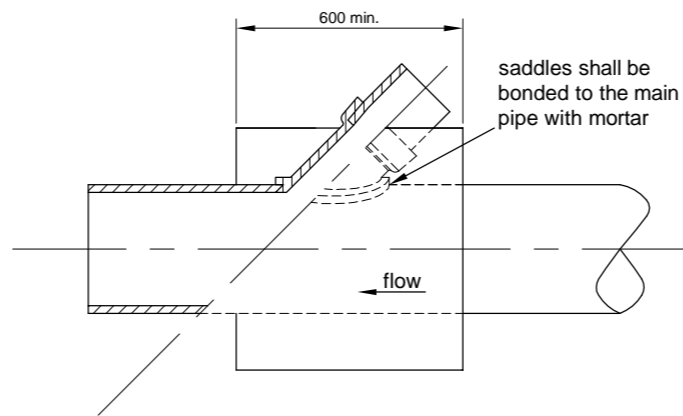

**ELEVATION/SECTION
(45° OBLIQUE SADDLE)**

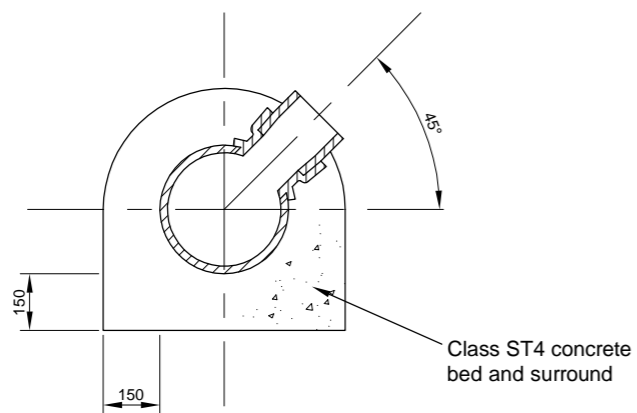

SECTION A-A

NOTES

1. All dimensions are in millimetres unless stated otherwise.
2. Mortar shall comply with S.H.W. Clause 2404 designation (i).
3. Pipe connections shall be inspected by the Overseeing Organisation prior to the placing of concrete saddles.
4. On connections where the main pipe is of a vitrified clay type not exceeding 225mm diameter, a length of pipe shall be cut out and replaced by a manufactured 'sleeve' type junction. The sleeve couplings, with their central register removed, shall be used to form a slip ring to enable the junction to be jointed to the main pipe.

| Permitted Connections | |
|-----------------------|--------------------------|
| Minor Pipe Dia. (mm) | Min. Main Pipe Dia. (mm) |
| 100 | 150 |
| 150 | 225 |
| 225 | 300 |
| 300 | 375 |



**HIGHWAY
CONSTRUCTION
DETAILS**

TITLE 1
DRAINAGE

TITLE 2
CONCRETE PIPE SADDLES

| | | | | |
|-----------------|----------|---|-------------------------------------|----------------------------|
| PREVIOUS ISSUES | | ALL DIMENSIONS IN MILLIMETRES UNLESS STATED OTHERWISE | ORIGINAL DRAWING SIZE 420mm x 297mm | |
| ISSUE | DATE | | DRN | RJB |
| 1 | FEB 2005 | NOT TO SCALE | CHKD | CS |
| | | DRG NO. F 707.1 | ISSUE STATUS 2 | ISSUE DATE MAY 2010 |

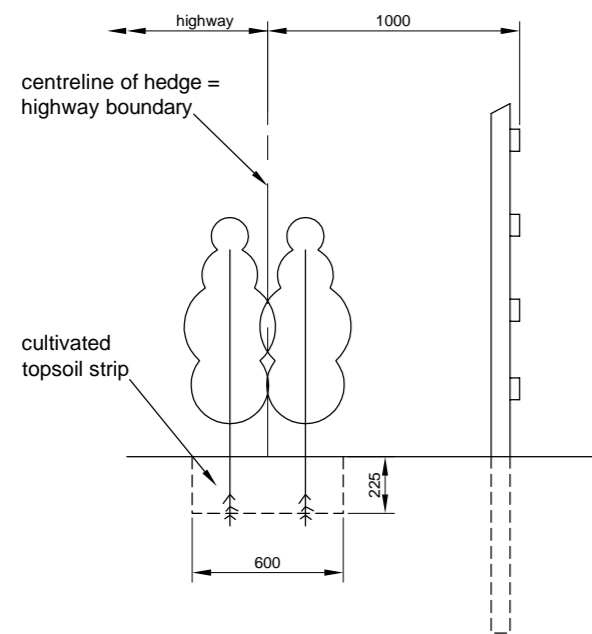

**SECTION A-A
(UNDISTURBED GROUND)**

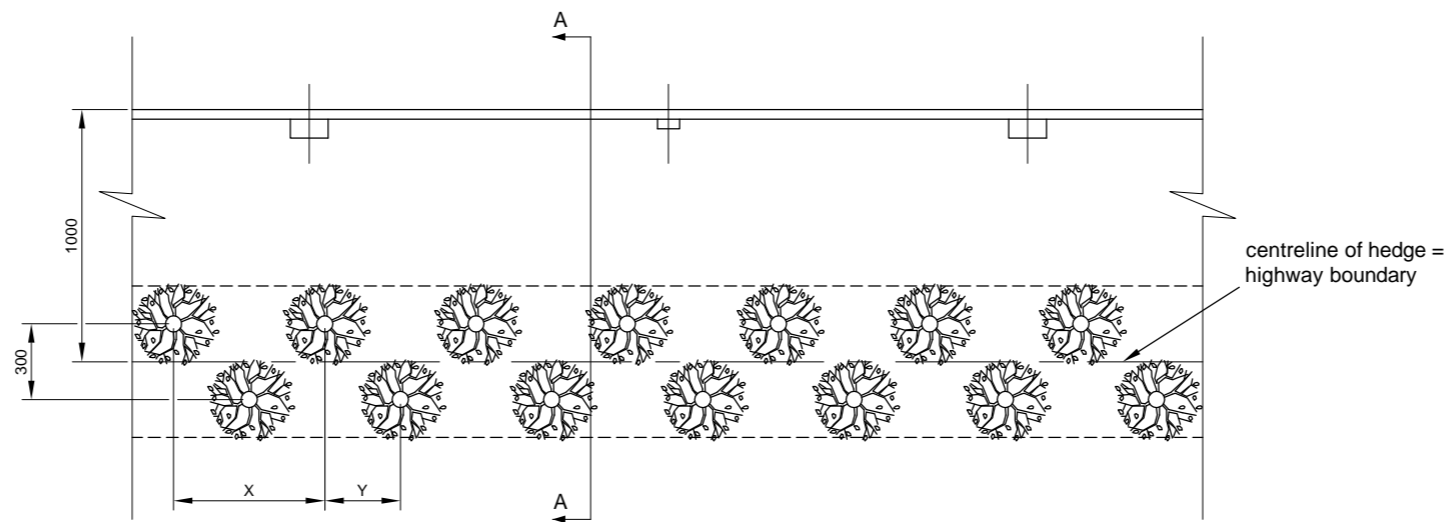

**BOUNDARY HEDGE
PLANTING DETAILS**

NOTES

1. All dimensions are in millimetres unless stated otherwise.
2. Dimension 'X' shall be 600mm and dimension 'Y' shall be 300mm unless specified otherwise by the Overseeing Organisation.
3. The cultivated topsoil strip shall be maintained free from weeds for a period of 3 years following completion of hedge planting.
4. In rural areas, hedge plant species shall be selected from those listed in the 'Warwickshire Landscape Guidelines' document for the particular geographic region that the hedge is to be planted. Copies of these documents are available for inspection upon request.

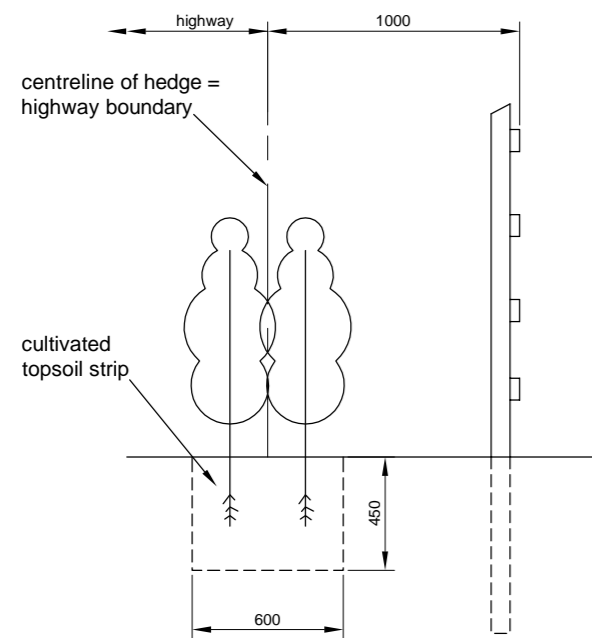

**SECTION A-A
(DISTURBED GROUND)**

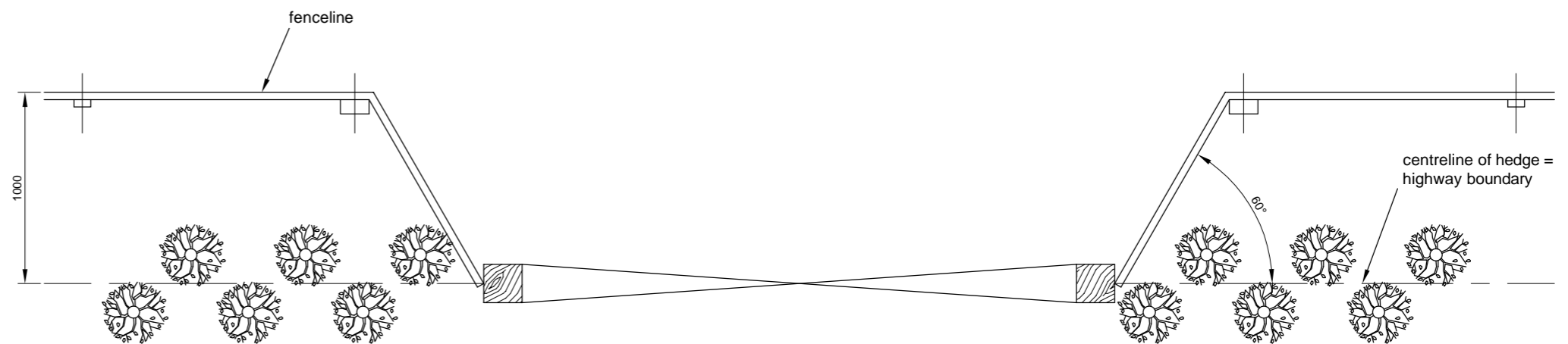

**BOUNDARY HEDGE
DETAIL AT FIELD GATE**



**HIGHWAY
CONSTRUCTION
DETAILS**

TITLE 1
**FENCES, STILES
AND GATES**

TITLE 2
BOUNDARY HEDGE

| PREVIOUS ISSUES | | ALL DIMENSIONS IN MILLIMETRES UNLESS STATED OTHERWISE | ORIGINAL DRAWING SIZE 420mm x 297mm | |
|-----------------|----------|---|-------------------------------------|---------------------|
| ISSUE | DATE | | DRN | CHKD |
| 1 | FEB 2005 | NOT TO SCALE | RJB | CS |
| | | DRG NO. H 701.1 | ISSUE STATUS 2 | ISSUE DATE MAY 2010 |

0mm 50mm 100mm 150mm 200mm

This plot was produced from a digital source so may not be at true scale. It is the recipient's responsibility to confirm its accuracy.

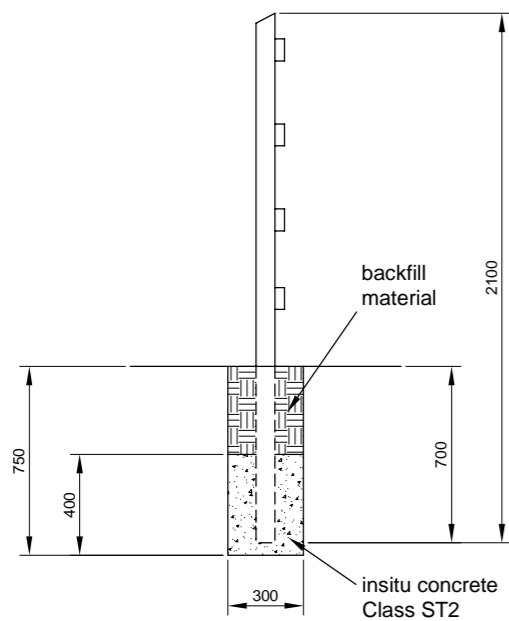

SECTION A-A

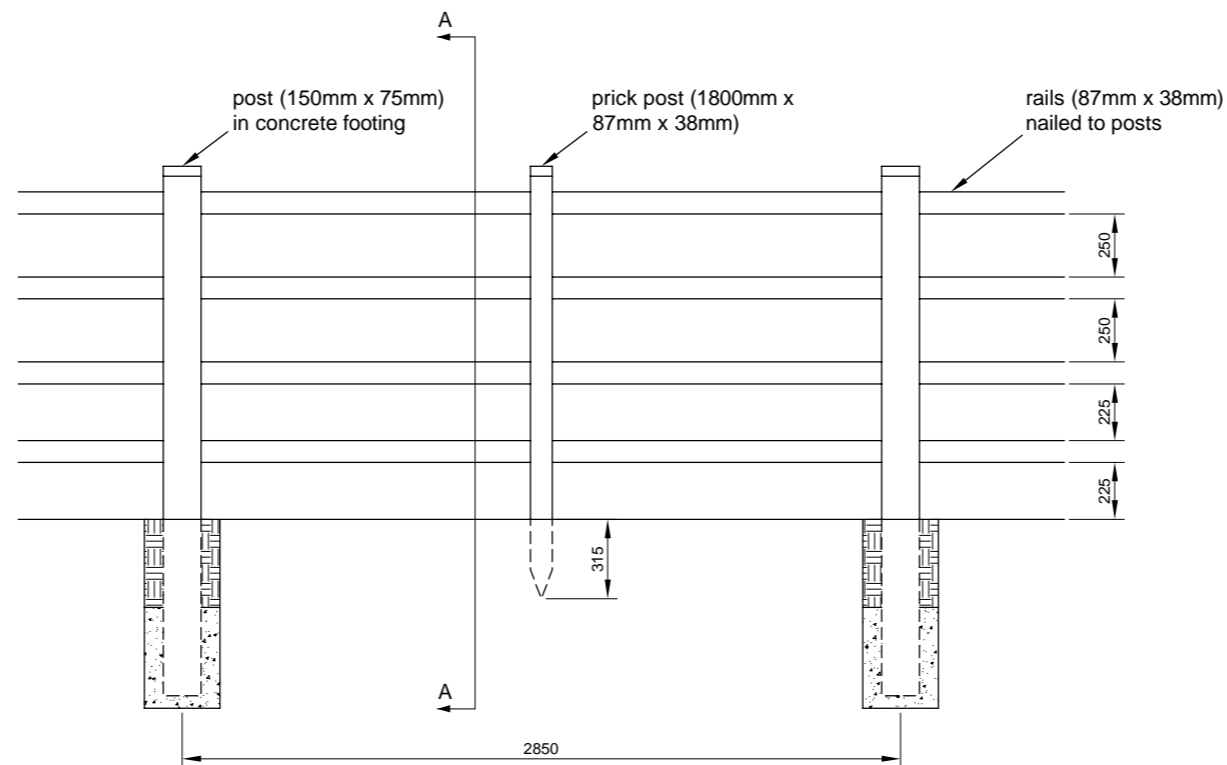

TIMBER POST AND FOUR RAIL FENCE

NOTES

1. All dimensions are in millimetres unless stated otherwise.
2. Fencing shall comply with S.H.W. Series 300 and BS 1722-7: 2006, except where contradicted by this construction detail.
3. Excavations for post footings shall have vertical sides, unless specified otherwise by the Overseeing Organisation.
4. Backfill shall be Class 1, 2A, 2B or 2C material in accordance with S.H.W. Table 6/1 overlaid with topsoil as specified.
5. Timber shall comply with S.H.W. Clause 304.
6. Prick posts shall be driven.
7. Rails for timber post and four rail fences shall be nailed (two no. nails per joint) to the post face facing away from the carriageway. Nails shall be galvanised.
8. Details of additional fencing fixtures are given in Appendix 3/1.

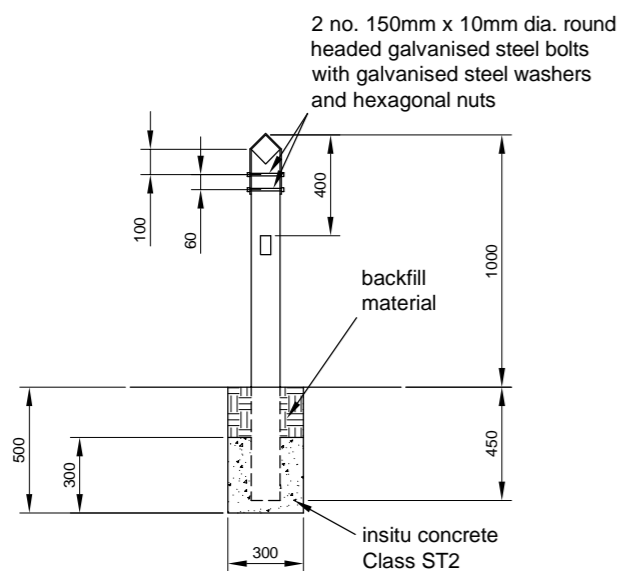

SECTION B-B

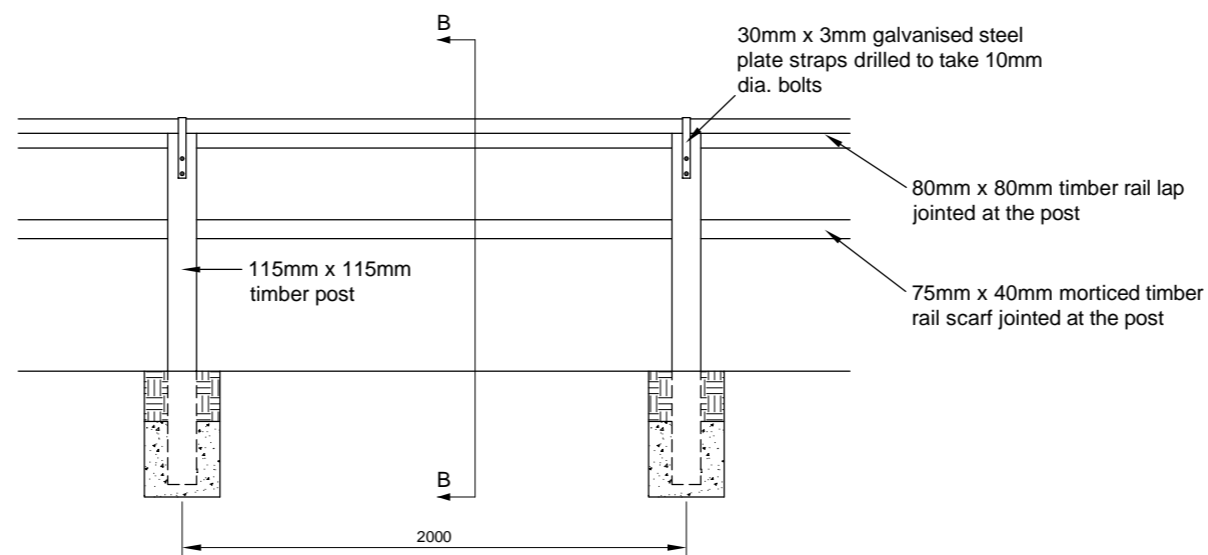

TIMBER POST AND TWO RAIL FENCE

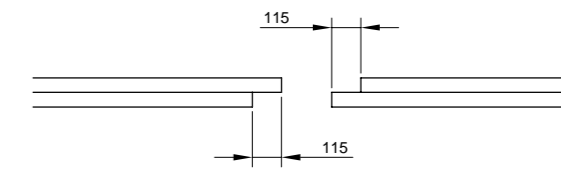

DETAIL OF SAWN LAP JOINT FOR TIMBER TOP RAIL



HIGHWAY CONSTRUCTION DETAILS

TITLE 1
FENCES, STILES AND GATES

TITLE 2
FENCING: TIMBER POST & RAIL

| PREVIOUS ISSUES | | ALL DIMENSIONS IN MILLIMETRES UNLESS STATED OTHERWISE | ORIGINAL DRAWING SIZE 420mm x 297mm | |
|-----------------|----------|---|-------------------------------------|------|
| ISSUE | DATE | | DRN | CHKD |
| 1 | FEB 2005 | NOT TO SCALE | RJB | CS |
| DRG NO. H 702.1 | | ISSUE STATUS 2 | ISSUE DATE MAY 2010 | |

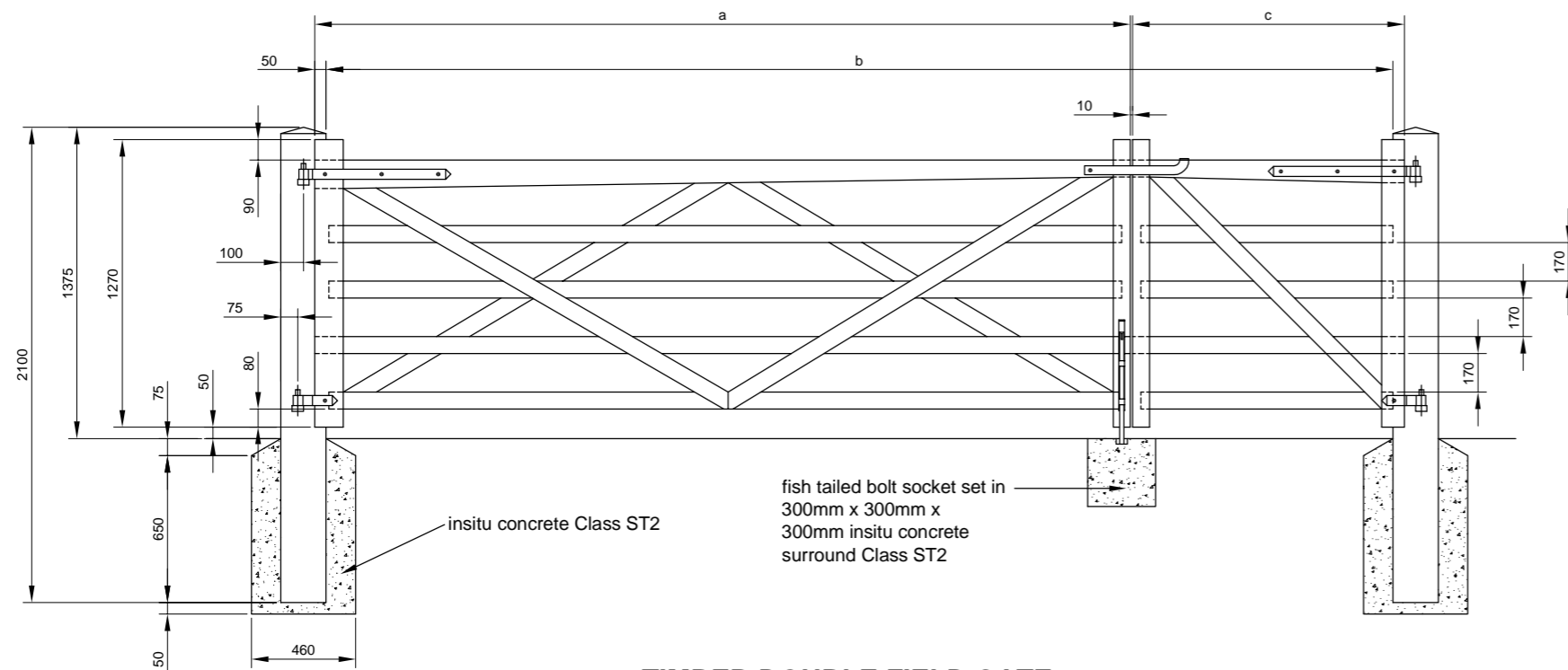

TIMBER DOUBLE FIELD GATE

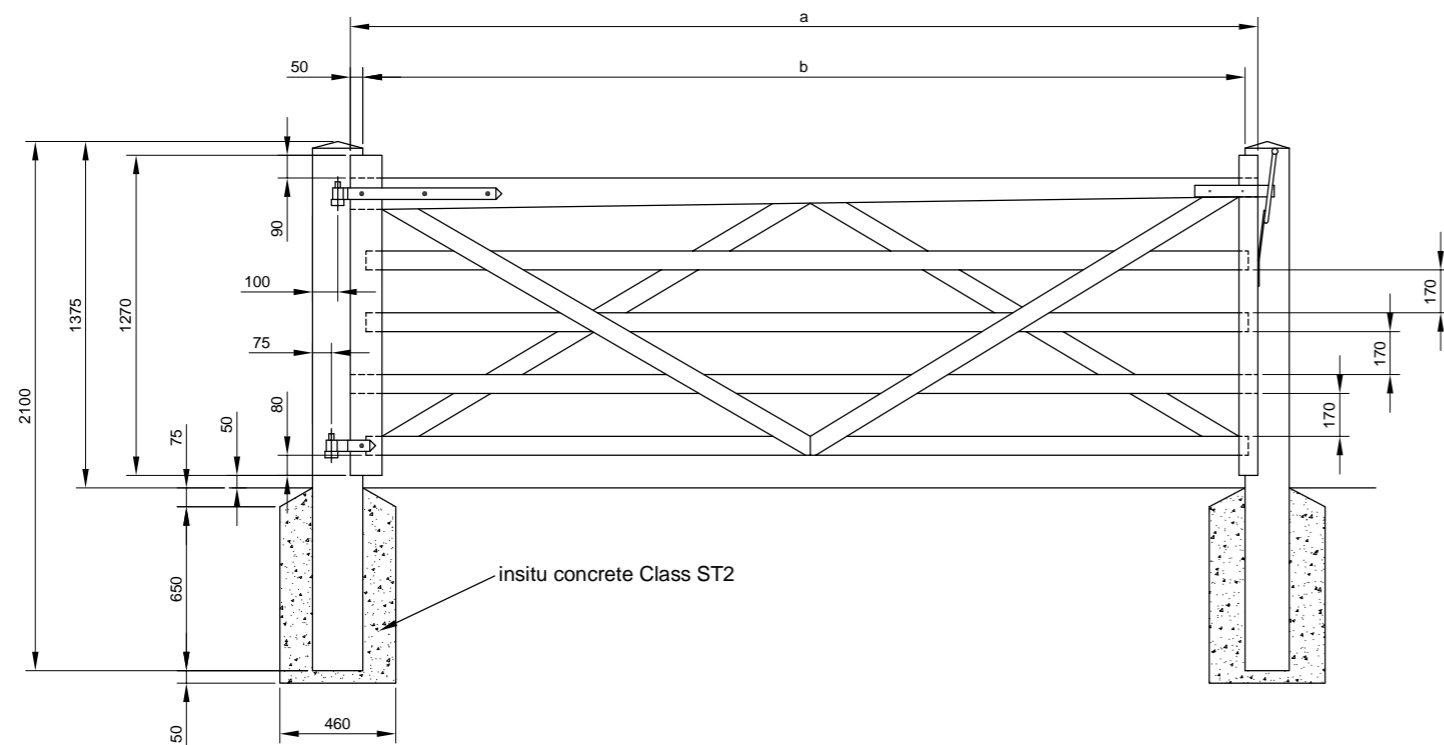

TIMBER SINGLE FIELD GATE

| DESCRIPTION OF TIMBER MATERIALS | DIMENSIONS (mm) |
|---------------------------------|--|
| hanging post | 200 x 200 x 2100 long |
| shutting post | 175 x 175 x 2100 long |
| hanging stile | 100 x 75 for gate Type 1 125 x 75 for gate Types 2 and 3 |
| shutting stile | 75 x 75 |
| top rail | 100 x 75 for gate Type 1 125 x 75 for gate Types 2 and 3 (all tapering to 75 x 75) |
| under rails | 75 x 75 |
| braces (housed in top rail) | 75 x 75 |

NOTES

1. All dimensions are in millimetres unless stated otherwise.
2. Gates shall comply with BS 3470: 1975 where appropriate, the relevant clauses of S.H.W. Series 300, and any additional requirements listed in Appendix 1/15 or 3/1.
3. All through tenons shall be pegged with 13mm dia. oak dowels.
4. On timber single field gates, hangings and fastenings shall comply with H.C.D.s H30 and H31 respectively. On timber double field gates hangings and fastenings shall comply with H.C.D.s H30 and H32 respectively.
5. Timber shall comply with S.H.W. Clause 304.
6. Gates shall be hung as shown for self closing gates with a self latching stop post. Refer to H.C.D. H33 for details.
7. Gates shall orientated to open into the land owner's property.
8. Where dimension 'C' for the additional gate on timber double field gates is 3000mm or less, the hanging stile and top rail dimensions shall match those for Type 1 gates.
9. Drop bolts and catches on double field gates shall be galvanised in accordance with BS EN ISO 1461: 2009

| TIMBER SINGLE FIELD GATE | | |
|--------------------------|--------------------|--------------------|
| GATE TYPE | DIMENSION 'a' (mm) | DIMENSION 'b' (mm) |
| 1 | 3000 | 2900 |
| 2 | 3600 | 3500 |
| 3 | 4200 | 4100 |

| TIMBER DOUBLE FIELD GATE | | | |
|--------------------------|--------------------|---------------------------------|---------------------------------|
| GATE TYPE | DIMENSION 'a' (mm) | DIMENSION 'b' (mm) | DIMENSION 'c' (mm) |
| 1 | 3000 | 4210, 4635, or 6010 | 1200, 1625, or 3000 |
| 2 | 3600 | 4810, 5235, 6610, or 7210 | 1200, 1625, 3000, or 3600 |
| 3 | 4200 | 5410, 5835, 7210, 7810, or 8410 | 1200, 1625, 3000, 3600, or 4200 |



**HIGHWAY
CONSTRUCTION
DETAILS**

TITLE 1

**FENCES, STILES
AND GATES**

TITLE 2

**TIMBER FIELD GATES:
TYPES 1, 2 & 3**



| PREVIOUS ISSUES | | ALL DIMENSIONS IN MILLIMETRES UNLESS STATED OTHERWISE | ORIGINAL DRAWING SIZE 420mm x 297mm | |
|-----------------|----------|---|-------------------------------------|----------------|
| ISSUE | DATE | | DRN | RJB |
| 1 | FEB 2005 | NOT TO SCALE | DRN | RJB |
| | | DRG NO. H 703.1 | ISSUE STATUS 2 | CHKD CS |
| | | | ISSUE DATE MAY 2010 | |

0mm 50mm 100mm 150mm 200mm

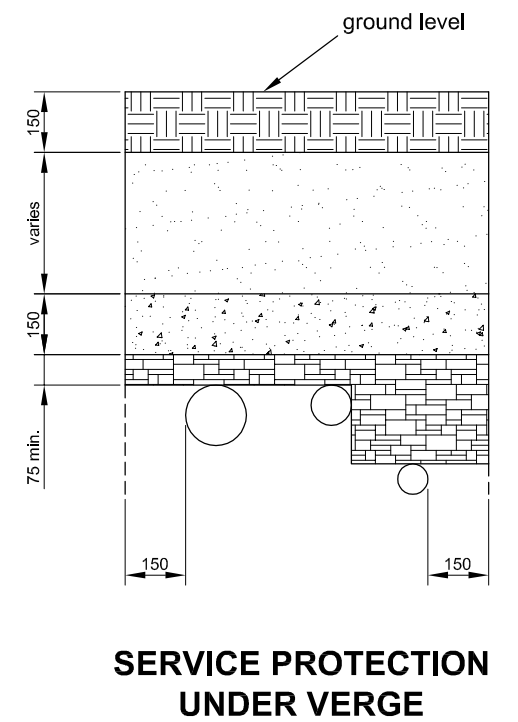
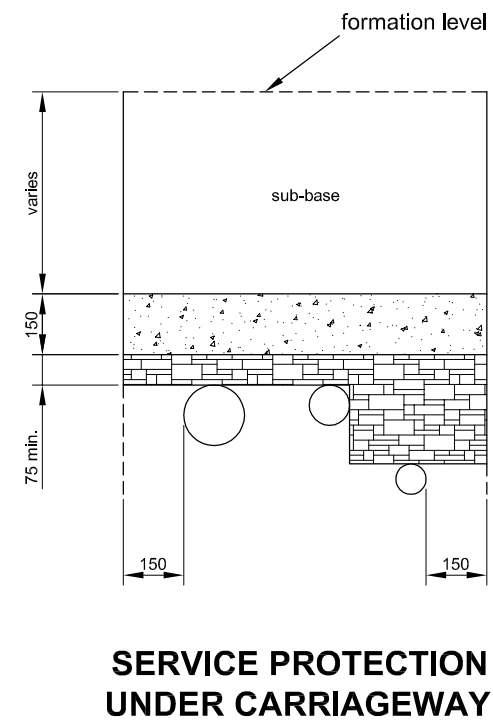
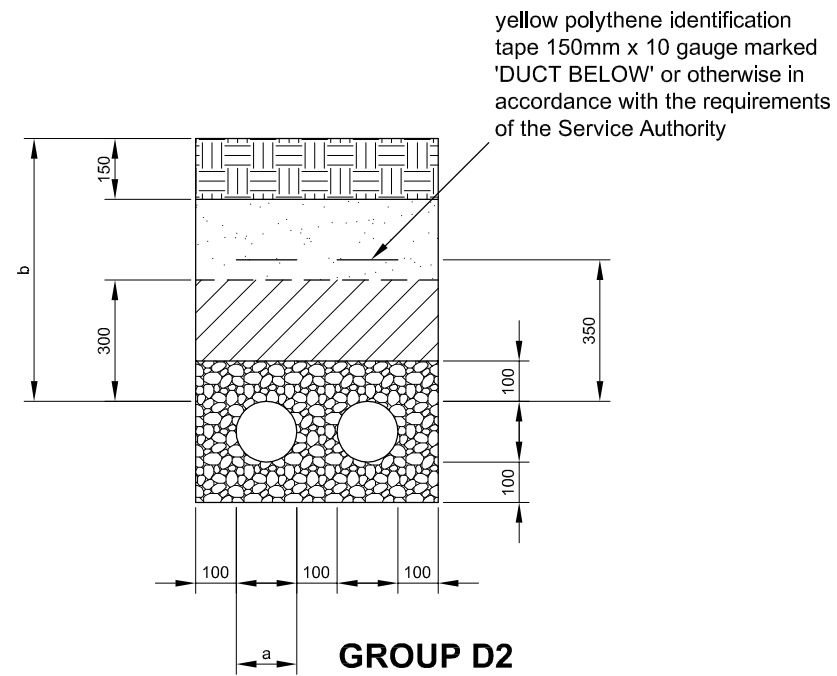
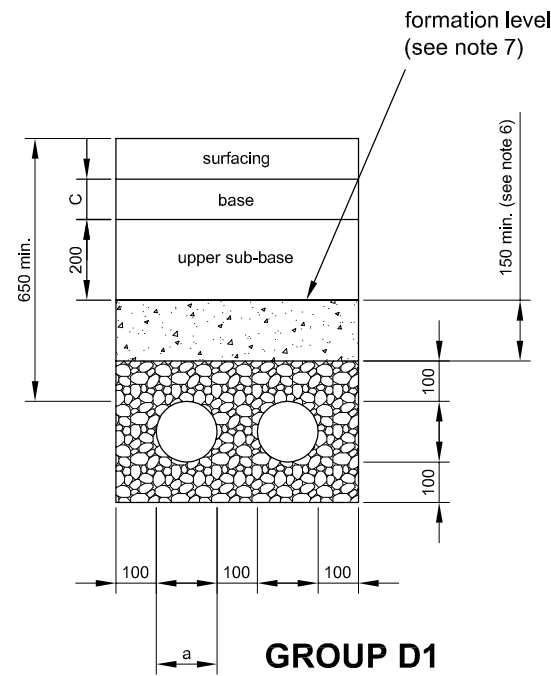
This plot was produced from a digital source so may not be at true scale. It is the recipient's responsibility to confirm its accuracy.

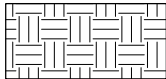

KEY

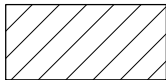
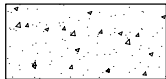
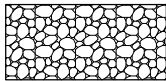
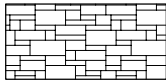
-  topsoil (where specified)
-  general fill material to S.H.W. Clause 505.2
-  Class 8 material to S.H.W. Clause 503.3(iv)
-  concrete to S.H.W. Clause 503.3(iii)
-  granular material to S.H.W. Clause 503.3(i)
-  sand protection

NOTES

1. All dimensions are in millimetres unless stated otherwise.
2. Ducts shall be manufactured from vitrified clay, UPVC or a suitable alternative material specified by the relevant Service Authority.
3. Refer to Appendix 5/2 for details of permissible alternative materials.
4. Dimension 'a' represents the external diameter of the duct.
5. Dimension 'b' represents the minimum cover requirement of the relevant Service Authority. Dimension 'b' shall be no less than 750mm.
6. Dimension 'c' represents the design thickness of base. Dimension 'c' shall be no less than 100mm.
7. Concrete protection on Group D1 ducts shall extend up to formation level and achieve a minimum thickness of 150mm.
8. Upper sub-base shall be Type 1 Unbound Mixtures to S.H.W Clause 803, Type 2 Unbound Mixtures (if they contain at least 80% bituminous plantings) to S.H.W Clause 804 or Type 3 (open graded) Unbound Mixtures to S.H.W Clause 805.
9. Where no lower sub-base layer is specified, the upper surface of concrete protection on Group D1 ducts shall be flush with sub-formation level.
10. Group D1 ducts shall extend to the edge of capping layer where no filter drain is specified, otherwise 500mm beyond the filter drain or to the back of footway (where specified), whichever is the greater dimension.
11. Refer to H.C.D. 11 for marker block details.
12. The minimum clearance between the outer surface of ducts and existing drains, service apparatus and the like shall be 100mm.
13. Refer to Appendix 5/2 and/or the scheme specific drawings for duct numbers, duct configurations, duct diameters and duct locations. The same principles shown in this detail for two-way ducts apply to multi-way duct configurations.

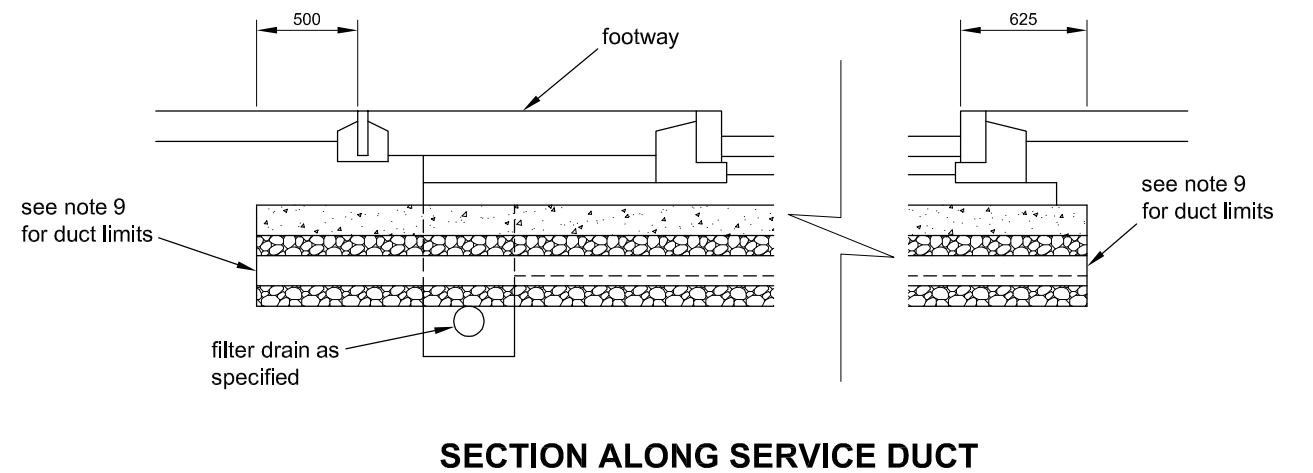

SECTION ALONG SERVICE DUCT

|  <p>HIGHWAY CONSTRUCTION DETAILS</p> | TITLE 1 | TITLE 2 | PREVIOUS ISSUES | ALL DIMENSIONS IN MILLIMETRES UNLESS STATED OTHERWISE | ORIGINAL DRAWING SIZE 420mm x 297mm | | | | | | | | | | | | | | | |
|---|---------------------------------------|---|---|---|-------------------------------------|---|----------|---|----------|--|--------------|-----|-----|------|----|------------------------|--------------|----------|------------|-----------------|
| | <p>UNDERGROUND CABLE DUCTS</p> | <p>NEW SERVICE DUCTS & PROTECTION OF EXISTING SERVICES</p> | <table border="1"> <tr> <th>ISSUE</th> <th>DATE</th> </tr> <tr> <td>1</td> <td>FEB 2005</td> </tr> <tr> <td>2</td> <td>MAY 2010</td> </tr> </table> | ISSUE | DATE | 1 | FEB 2005 | 2 | MAY 2010 | <table border="1"> <tr> <td>NOT TO SCALE</td> <td>DRN</td> <td>RJB</td> <td>CHKD</td> <td>CS</td> </tr> <tr> <td>DRG NO. I 701.1</td> <td>ISSUE STATUS</td> <td>3</td> <td>ISSUE DATE</td> <td>FEB 2013</td> </tr> </table> | NOT TO SCALE | DRN | RJB | CHKD | CS | DRG NO. I 701.1 | ISSUE STATUS | 3 | ISSUE DATE | FEB 2013 |
| ISSUE | DATE | | | | | | | | | | | | | | | | | | | |
| 1 | FEB 2005 | | | | | | | | | | | | | | | | | | | |
| 2 | MAY 2010 | | | | | | | | | | | | | | | | | | | |
| NOT TO SCALE | DRN | RJB | CHKD | CS | | | | | | | | | | | | | | | | |
| DRG NO. I 701.1 | ISSUE STATUS | 3 | ISSUE DATE | FEB 2013 | | | | | | | | | | | | | | | | |

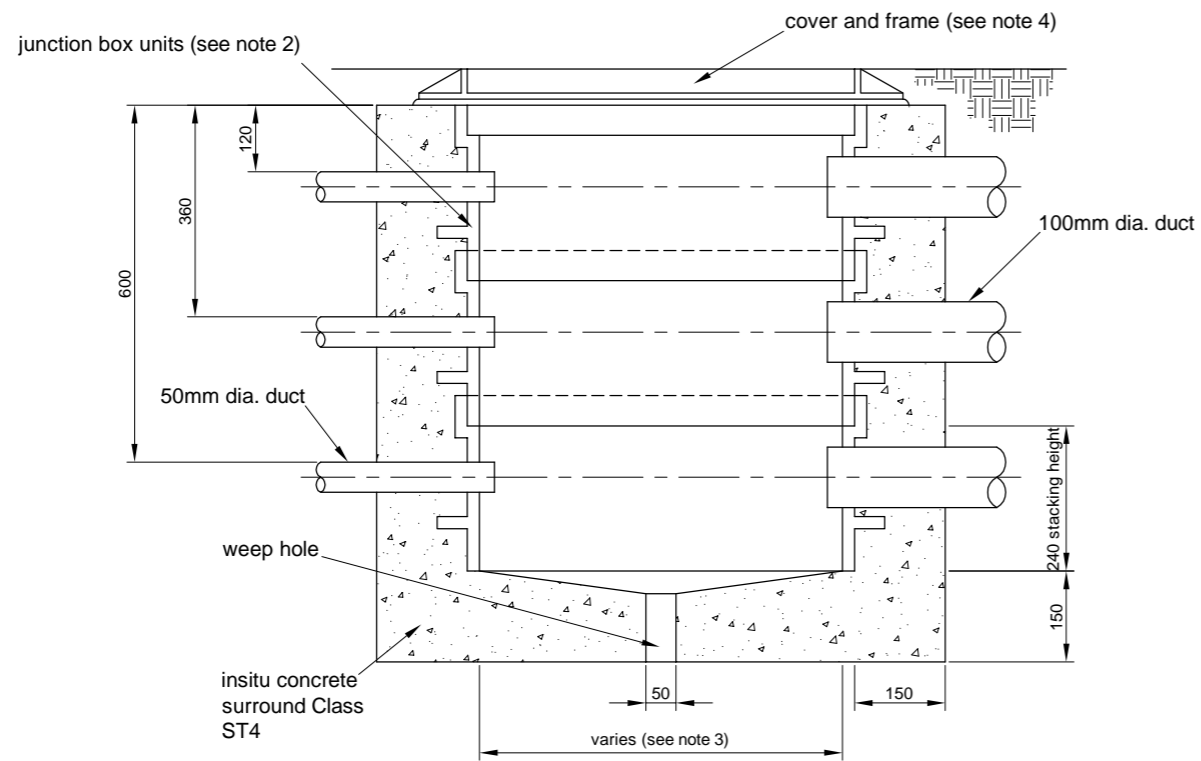

TYPICAL SECTION THROUGH JUNCTION BOX

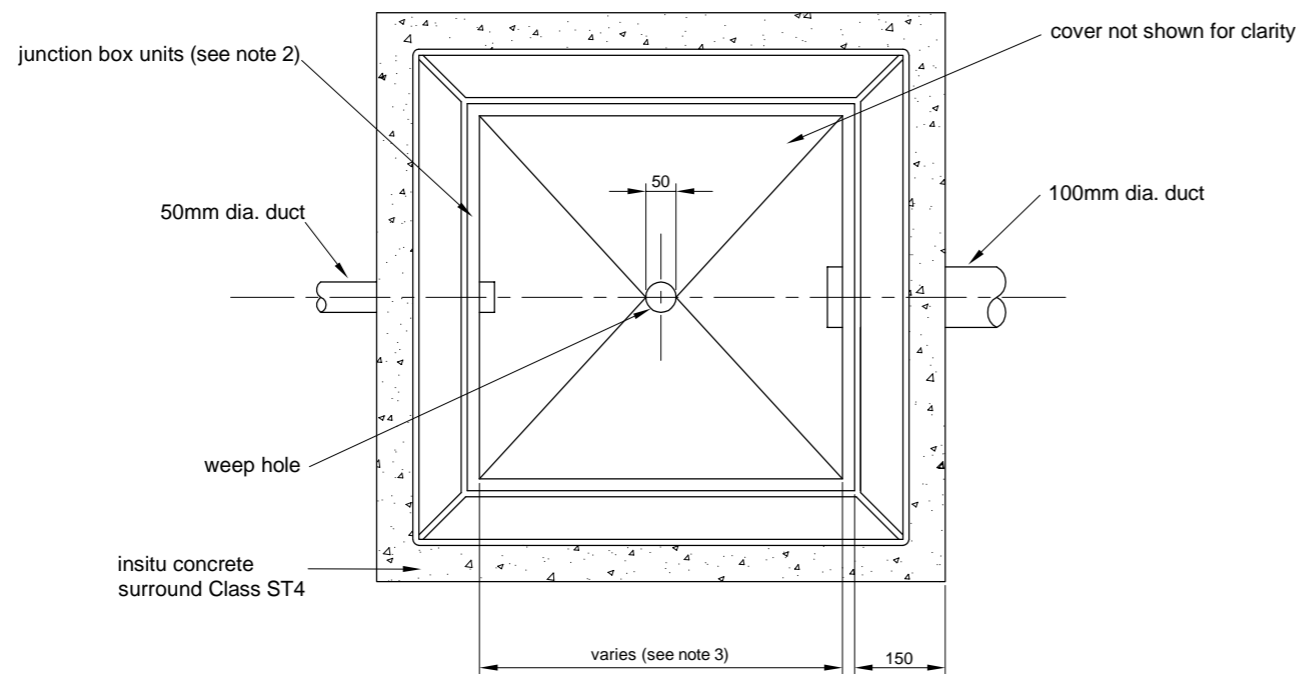

PLAN VIEW OF JUNCTION BOX

NOTES

1. All dimensions are in millimetres unless stated otherwise.
2. Junction box units shall be of a type approved in advance by the Overseeing Organisation, or as specified on the scheme specific contract drawings.
3. Junction box internal opening dimensions shall be 290mm x 275mm, 450mm x 450mm or 600mm x 450mm as specified on the scheme specific contract drawings.
4. Both cover and frame shall be of a type suitable for vehicle loading and shall be approved in advance by the Overseeing Organisation.



**HIGHWAY
CONSTRUCTION
DETAILS**

| | |
|----------------------------|--------------------------------|
| TITLE 1 | TITLE 2 |
| UNDERGROUND CABLE DUCTS | JUNCTION BOX FOR SERVICE DUCTS |

| | | | | | |
|-----------------|----------|---|-------------------------------------|------------|----|
| PREVIOUS ISSUES | | ALL DIMENSIONS IN MILLIMETRES UNLESS STATED OTHERWISE | ORIGINAL DRAWING SIZE 420mm x 297mm | | |
| ISSUE | DATE | | | CHKD | CS |
| 1 | FEB 2005 | NOT TO SCALE | DRN | RJB | |
| | | DRG NO. | ISSUE STATUS | ISSUE DATE | |
| | | 1 702.1 | 2 | MAY 2010 | |

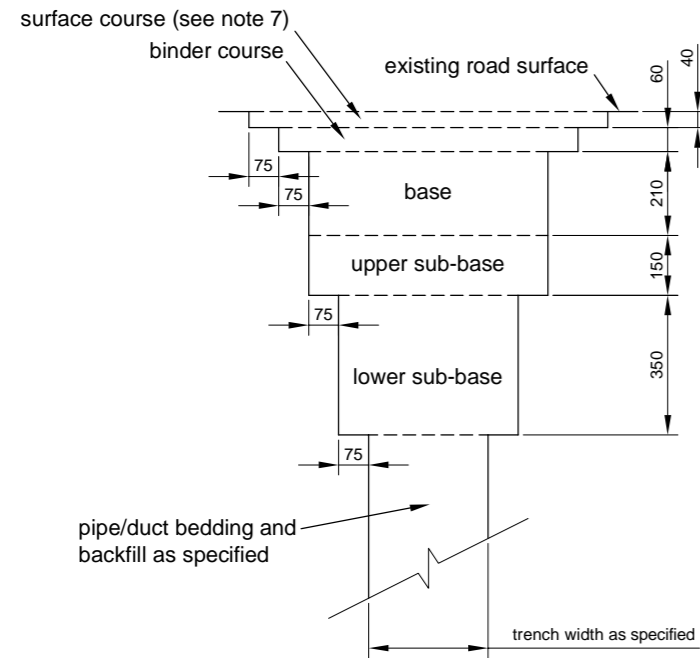

TYPE 1 DETAIL

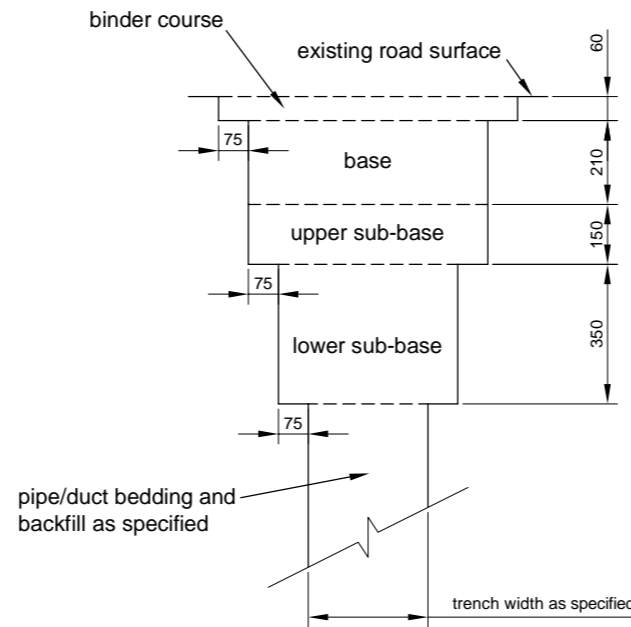

TYPE 2 DETAIL

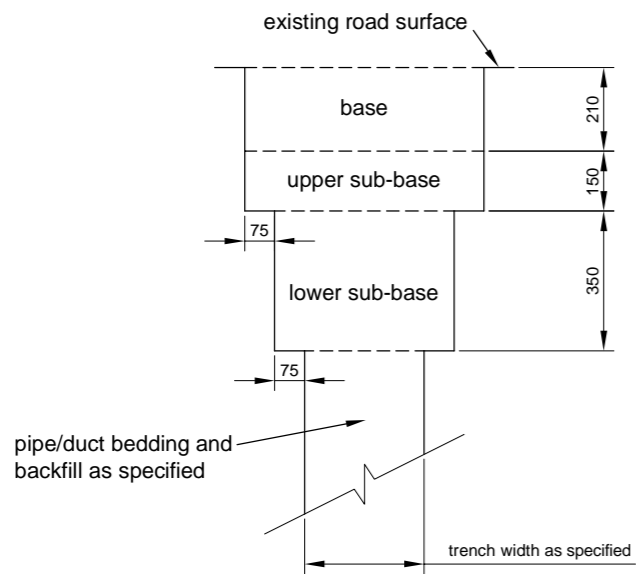

TYPE 3 DETAIL

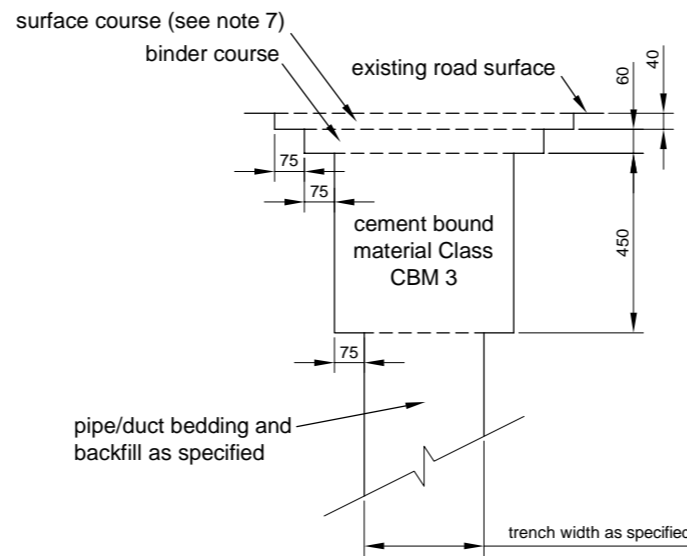

TYPE 4 DETAIL

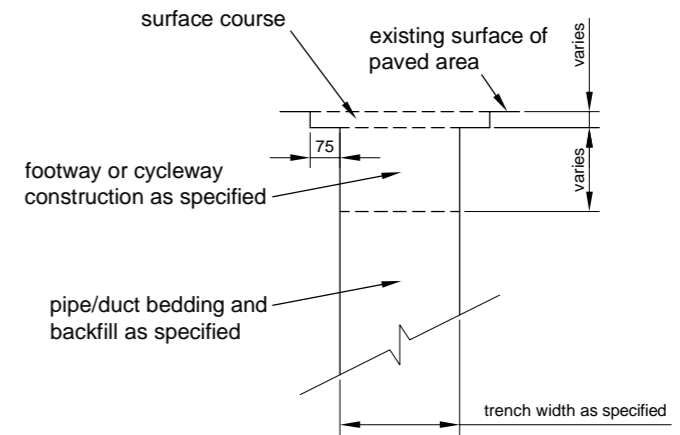

**TYPE 5 DETAIL
(PAVED AREAS)**

NOTES

1. All dimensions are in millimetres unless stated otherwise.
2. Pavement materials shall be as specified in Appendix 7/1, or where no contract specification applies, in accordance with WCC's Surfacing and Structural Maintenance Strategy.
3. Longitudinal joints in the surface course shall be saw cut.
4. In narrow trenches where bituminous materials cannot be adequately compacted, cement bound material (Class CBM 3) shall be used in lieu of unbound sub-base, bituminous base and binder course material as appropriate.
5. For measurement purposes, the trench width shall be the minimum permitted for the specified type of drain, duct or other service.
6. Where applicable, alterations to the thicknesses of materials will be detailed in Appendix 7/2.
7. Where hot rolled asphalt surface courses are specified, the thickness of surface course may be increased up to a maximum of 50mm. In this instance, the thickness of binder course will be reduced to 50mm.



HIGHWAY
CONSTRUCTION
DETAILS

TITLE 1

MISCELLANEOUS

TITLE 2

TRENCH REINSTATEMENT IN
CARRIAGEWAYS & PAVED AREAS

| PREVIOUS ISSUES | |
|-----------------|----------|
| ISSUE | DATE |
| 1 | FEB 2005 |
| | |
| | |

| | |
|---|------------------------|
| ALL DIMENSIONS IN MILLIMETRES UNLESS STATED OTHERWISE | |
| NOT TO SCALE | DRG NO. K 701.1 |

| | |
|-------------------------------------|----------------------------|
| ORIGINAL DRAWING SIZE 420mm x 297mm | |
| DRN | RJB |
| ISSUE STATUS 2 | ISSUE DATE MAY 2010 |

CHKD CS

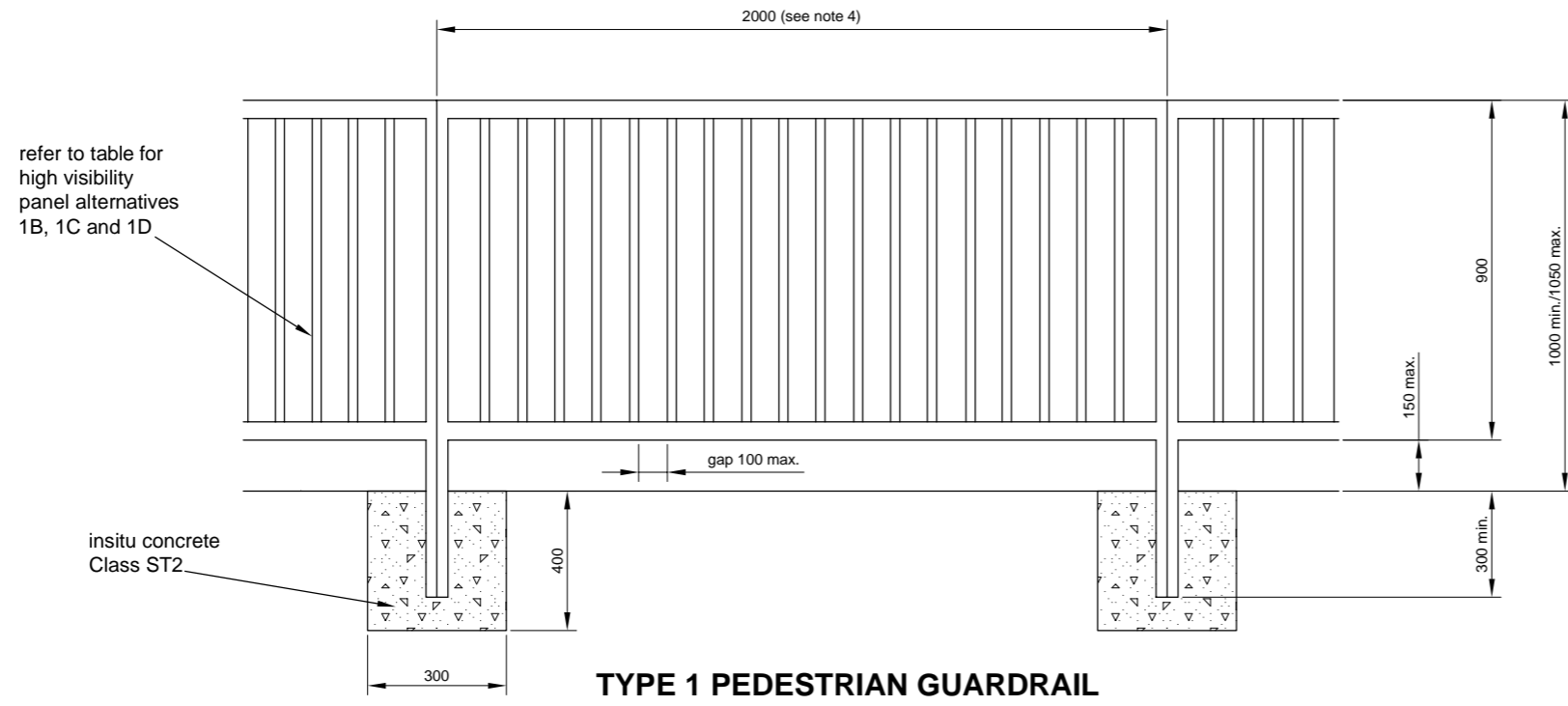

TYPE 1 PEDESTRIAN GUARDRAIL

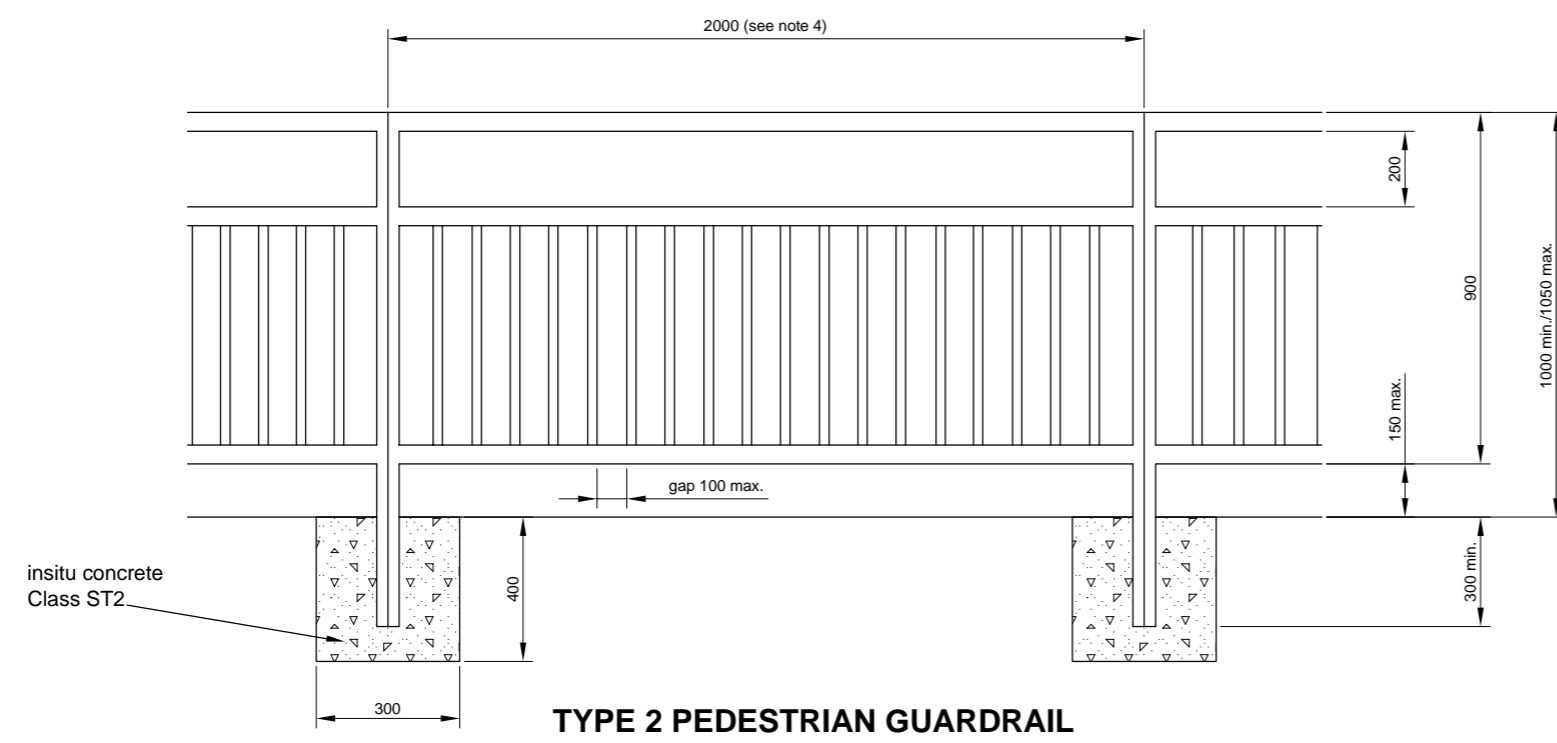

TYPE 2 PEDESTRIAN GUARDRAIL

NOTES

1. All dimensions are in millimetres unless stated otherwise.
2. Pedestrian guardrails, including infilling panels shall be of steel manufacture (with hot dip galvanised finish) to BS 7818: 1995.
3. The need for non-standard parts to overcome tight horizontal radii or steep vertical gradients shall be determined from the scheme specific drawings.
4. Shorter panels may be used, subject to approval in advance by the Overseeing Organisation.
5. Pedestrian Guardrails shall be set back from the kerb face a distance exceeding 450mm but not exceeding 600mm.
6. Panel types V2, V4 and V8 are high visibility pedestrian guardrail panels for use in the vicinity of pedestrian crossings.
7. Where pedestrian guardrail is to be fixed to the top of a concrete wall to act as a parapet, anchorage and fixing details will be shown on scheme specific drawings.

| Guardrail Details | | | |
|-------------------|------------|--------------|---------------------|
| Guardrail Type | Panel Type | Panel Layout | Optimum Sight Angle |
| 1A | standard | as shown | not applicable |
| 1B | V2 | | 2.5° - 5.0° |
| 1C | V4 | | 5.0° - 14.0° |
| 1D | V8 | | exceeding 14.0° |
| 2 | standard | as shown | not applicable |



HIGHWAY CONSTRUCTION DETAILS

TITLE 1
MISCELLANEOUS

TITLE 2
PEDESTRIAN GUARDRAILS

| | | | | |
|------------------------|----------|---|-------------------------------------|------|
| PREVIOUS ISSUES | | ALL DIMENSIONS IN MILLIMETRES UNLESS STATED OTHERWISE | ORIGINAL DRAWING SIZE 420mm x 297mm | |
| ISSUE | DATE | | DRN | CHKD |
| 1 | FEB 2005 | NOT TO SCALE | RJB | CS |
| DRG NO. K 702.1 | | ISSUE STATUS 2 | ISSUE DATE MAY 2010 | |

0mm 50mm 100mm 150mm 200mm

This plot was produced from a digital source so may not be at true scale. It is the recipient's responsibility to confirm its accuracy.

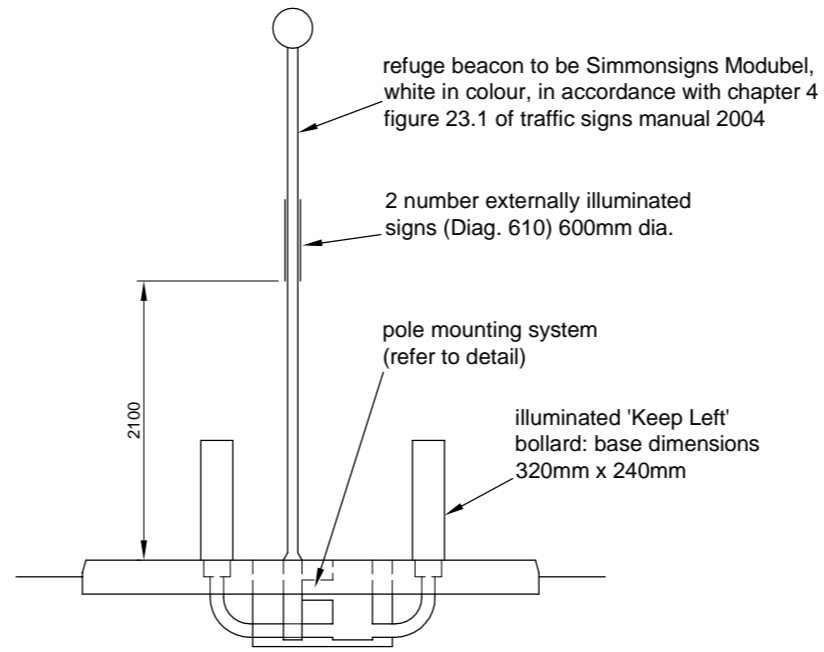
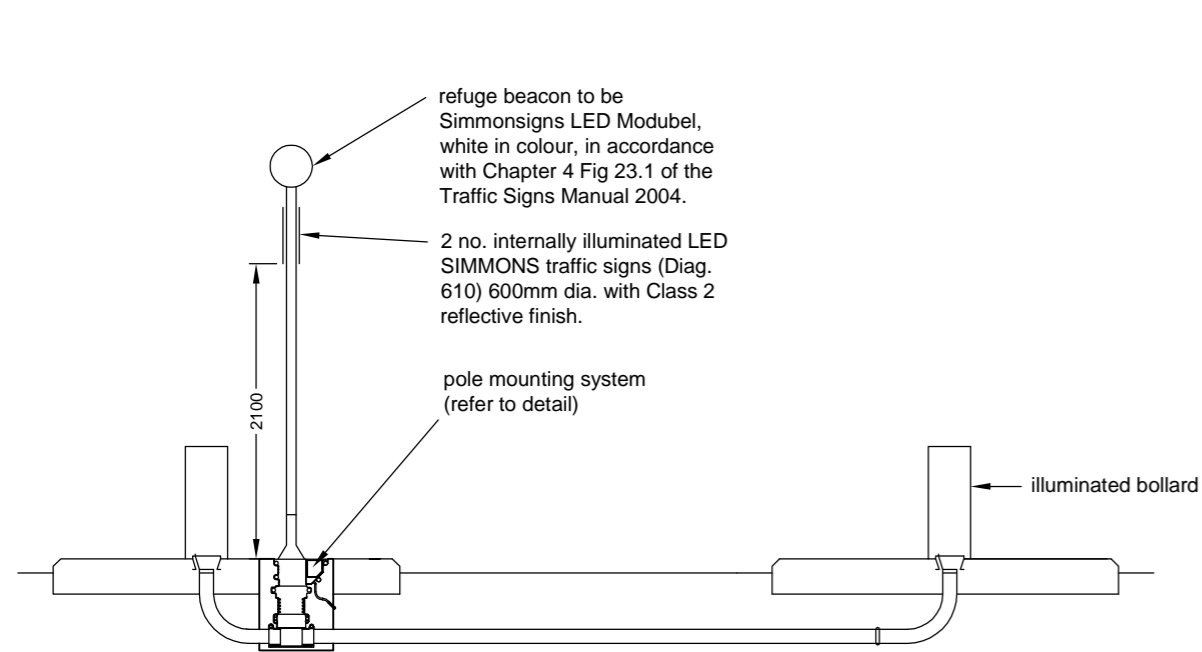

NOTES

1. All dimensions are in millimetres unless stated otherwise.
2. Refer to B 702.1 for kerbing details.
3. Dropper kerb Types DR1 and DL1 shall be cut to form a vertical joint with adjacent Type HB2 kerbs.
4. Type BN kerbs shall be laid with a maximum upstand of 6mm above carriageway.
5. Refuge islands shall be of Type 1 footway construction. Refer to B 704.1 for details.
6. Tactile blister paving shall be red at controlled crossings, otherwise buff in colour. Tactile blister paving shall comprise 400mm x 400mm x 50mm precast concrete paving bedded on 25mm moist sand/cement mortar (3:1), joints filled with 4:1 mix to within 2mm of the paving surface. Paving shall be Type A as defined in Fig. 2 of the 'Guidance on the Use of Tactile Paving Surfaces' Department of Transport.
7. Alternative proposals to the pole mounting system shown on this detail shall be approved in advance by the Overseeing Organisation.
8. Duct crossing shall comprise 1 No. 100mm internal diameter high density polyethylene, smooth single wall orange service duct, across carriageway in concrete surround with drawcord (minimum cover 600mm). Refer to I 701.1, Notes for Guidance Annex 1 and Appendix 5/2 for duct group details.
9. For details on Flecta bollards see drawing K 703.5
10. Pedestrian refuges narrower than 2000mm shall only be provided in locations where the full 2000mm cannot be achieved.

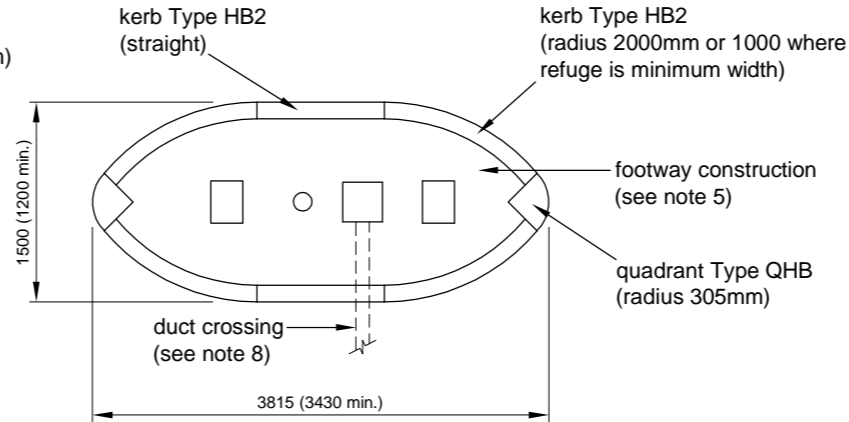
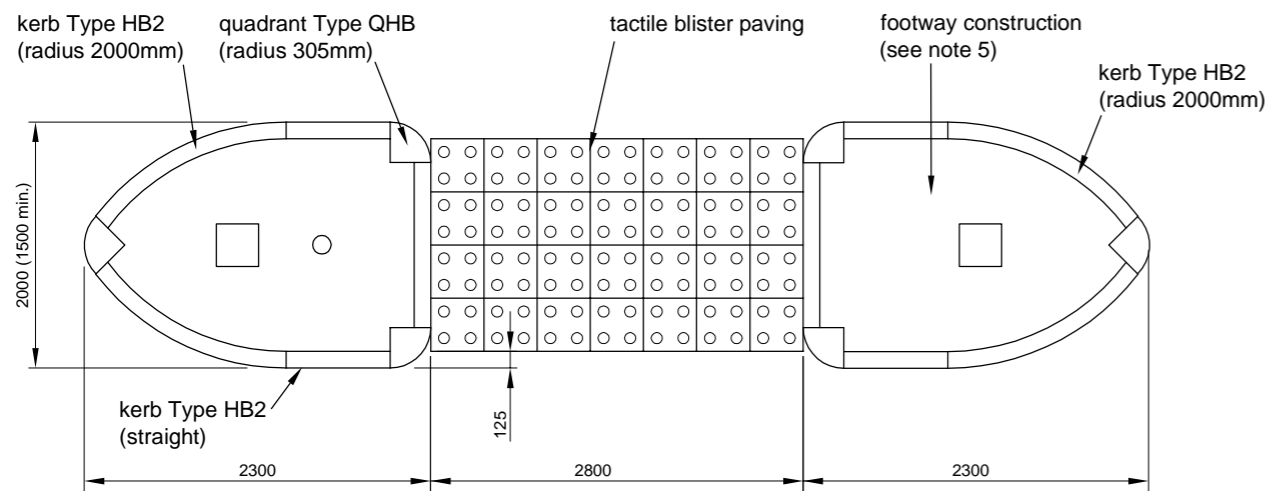

STANDARD ILLUMINATED REFUGE

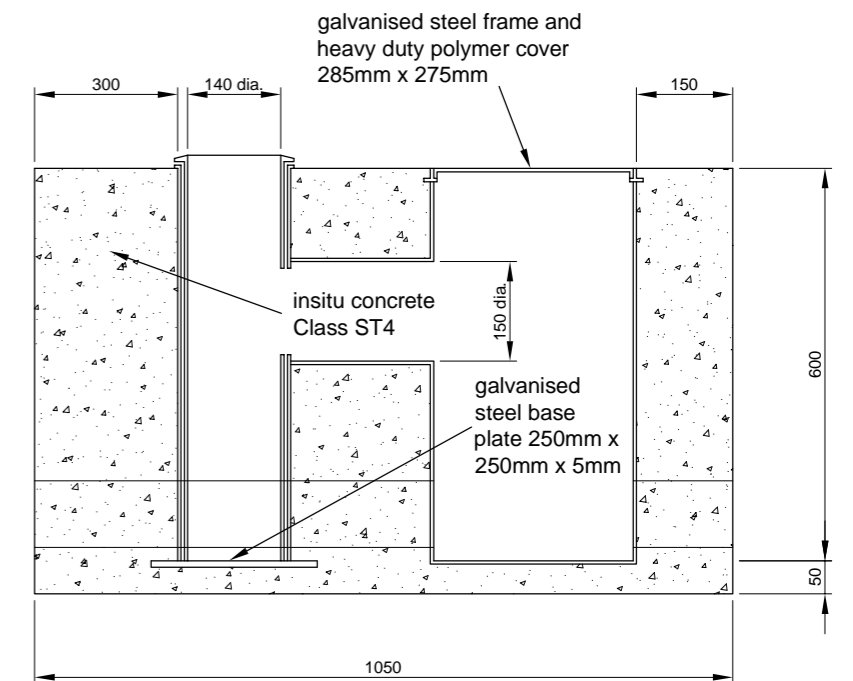

POLE MOUNTING SYSTEM

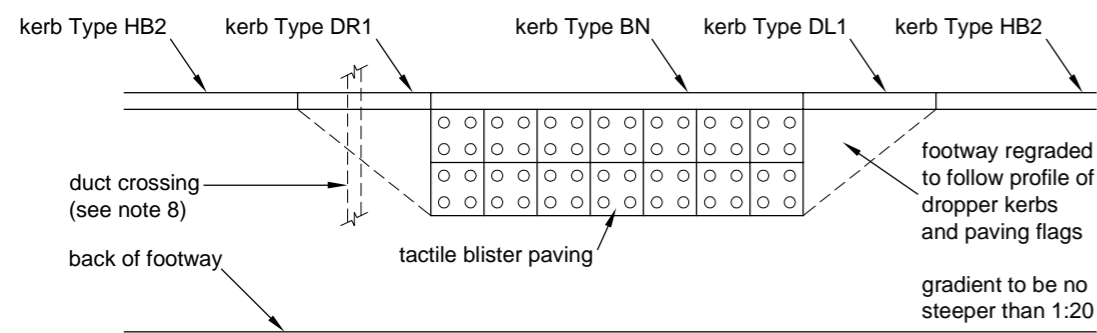

STANDARD ILLUMINATED PEDESTRIAN REFUGE

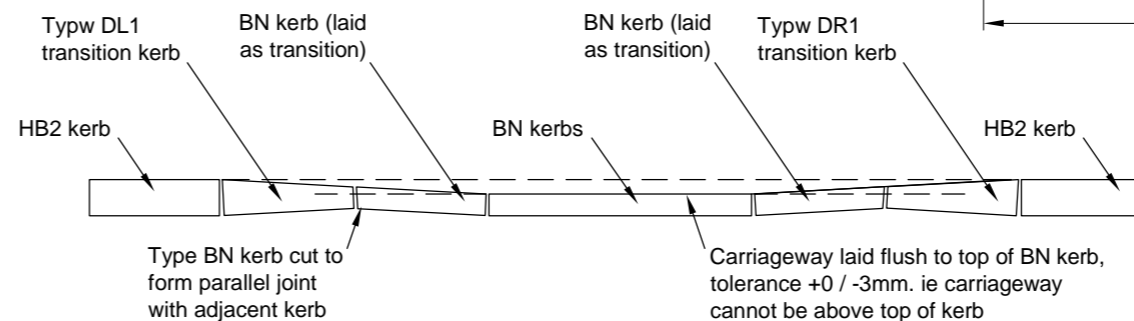

KERB DETAILS TO ACHIEVE GRADIENT OF 1:11 OR FLATTER



HIGHWAY CONSTRUCTION DETAILS

| | |
|---------|---------------|
| TITLE 1 | MISCELLANEOUS |
|---------|---------------|

| | |
|---------|---|
| TITLE 2 | STANDARD ILLUMINATED REFUGE AND PEDESTRIAN REFUGE |
|---------|---|

| | | | | |
|-----------------|---|-------------------------------------|---------|---------------------|
| PREVIOUS ISSUES | ALL DIMENSIONS IN MILLIMETRES UNLESS STATED OTHERWISE | ORIGINAL DRAWING SIZE 420mm x 297mm | | |
| ISSUE | DATE | NOT TO SCALE | DRN | RJB |
| 1 | FEB 2005 | | | CHKD CS |
| 2 | MAY 2010 | DRG NO. | K 703.1 | ISSUE STATUS 3 |
| | | | | ISSUE DATE OCT 2010 |

NOTES

1. All dimensions are in millimetres unless stated otherwise.
2. Refer to B 702.1 for kerbing details.
3. Dropper kerb Types DR1 and DL1 shall be cut to form a vertical joint with adjacent Type HB2 kerbs.
4. Type BN kerbs shall be laid with a maximum upstand of 6mm above carriageway.
5. Refuge islands shall be of Type 1 footway construction. Refer to B 704.1 for details.
6. Tactile blister paving shall be red at controlled crossings, otherwise buff in colour. Tactile blister paving shall comprise 400mm x 400mm x 50mm precast concrete paving bedded on 25mm moist sand/cement mortar (3:1), joints filled with 4:1 mix to within 2mm of the paving surface. Paving shall be Type A as defined in Fig. 2 of the 'Guidance on the Use of Tactile Paving Surfaces' Department of Transport.
7. For details on Flecta bollards see drawing K 703.5
8. Pedestrian refuges narrower than 2000mm shall only be provided in locations where the full 2000mm cannot be achieved.

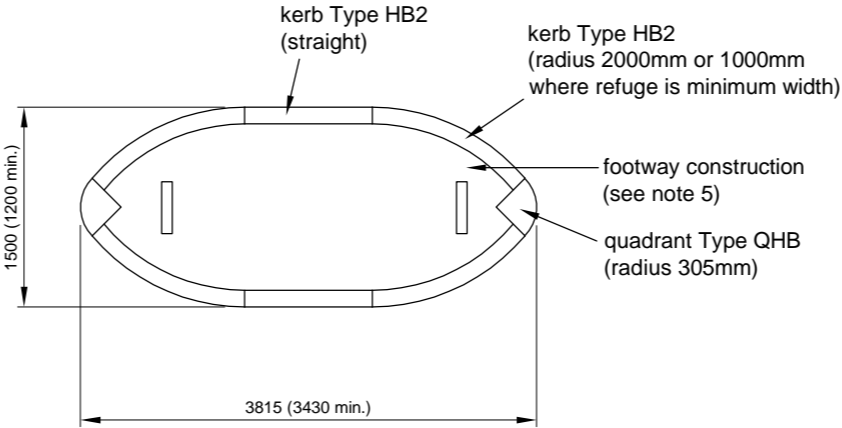
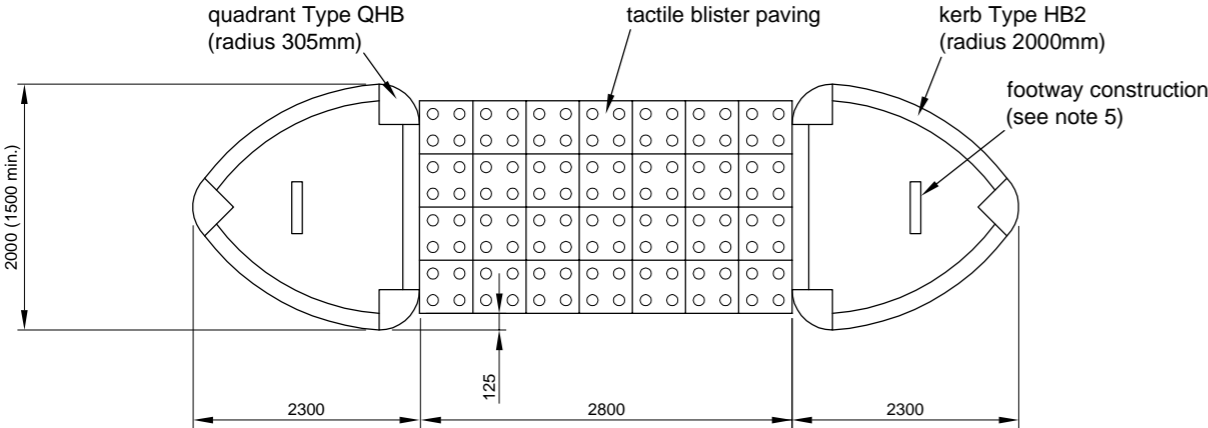
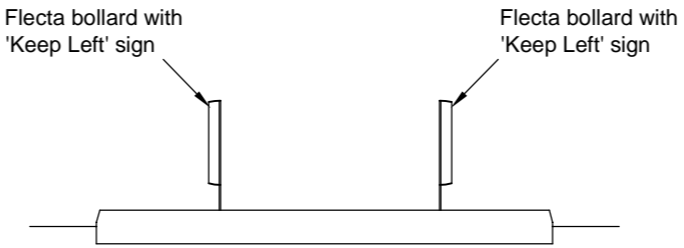

REFUGE WITH FLEXIBLE SIGNAGE

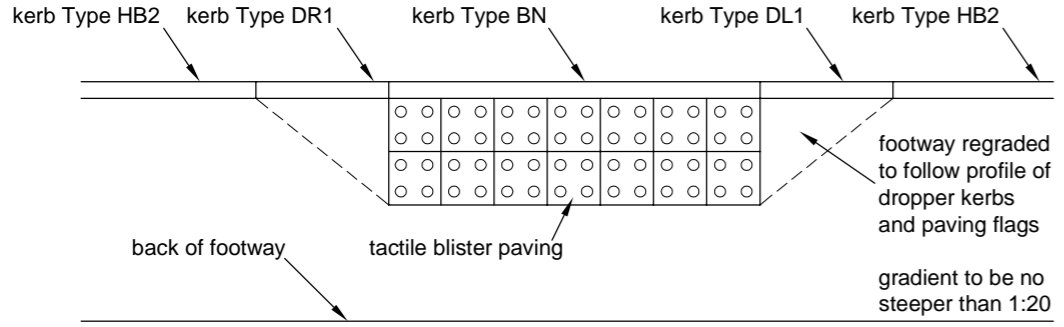

PEDESTRIAN REFUGE WITH FLEXIBLE SIGNAGE

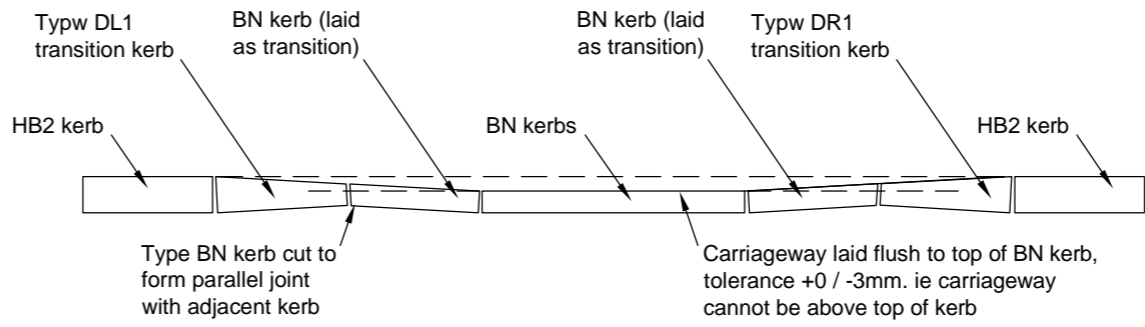

KERB DETAILS TO ACHIEVE GRADIENT OF 1:11 OR FLATTER



HIGHWAY CONSTRUCTION DETAILS

TITLE 1
MISCELLANEOUS

TITLE 2
REFUGE AND PEDESTRIAN REFUGE WITH FLEXIBLE SIGNAGE

| PREVIOUS ISSUES | | ALL DIMENSIONS IN MILLIMETRES UNLESS STATED OTHERWISE | ORIGINAL DRAWING SIZE 420mm x 297mm | |
|-----------------|----------|---|-------------------------------------|--|
| ISSUE | DATE | | DRN | RJB |
| 1 | FEB 2005 | NOT TO SCALE | | CHKD CS |
| 2 | MAY 2010 | DRG NO. | K 703.2 | ISSUE STATUS 3 ISSUE DATE OCT 2010 |

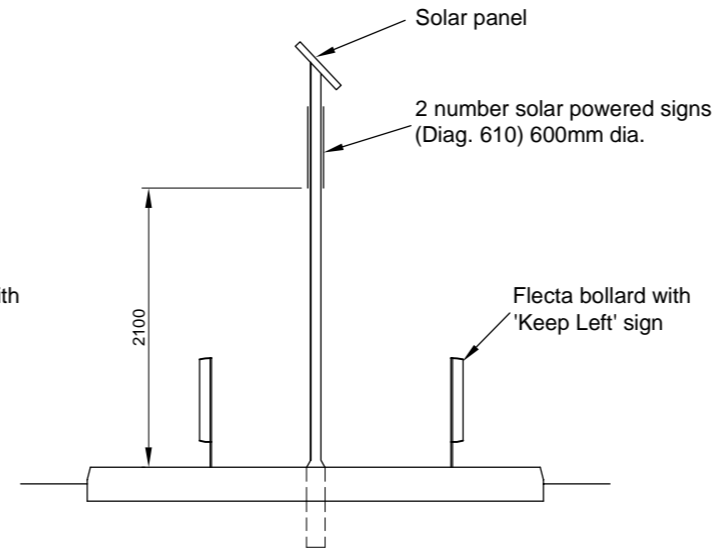
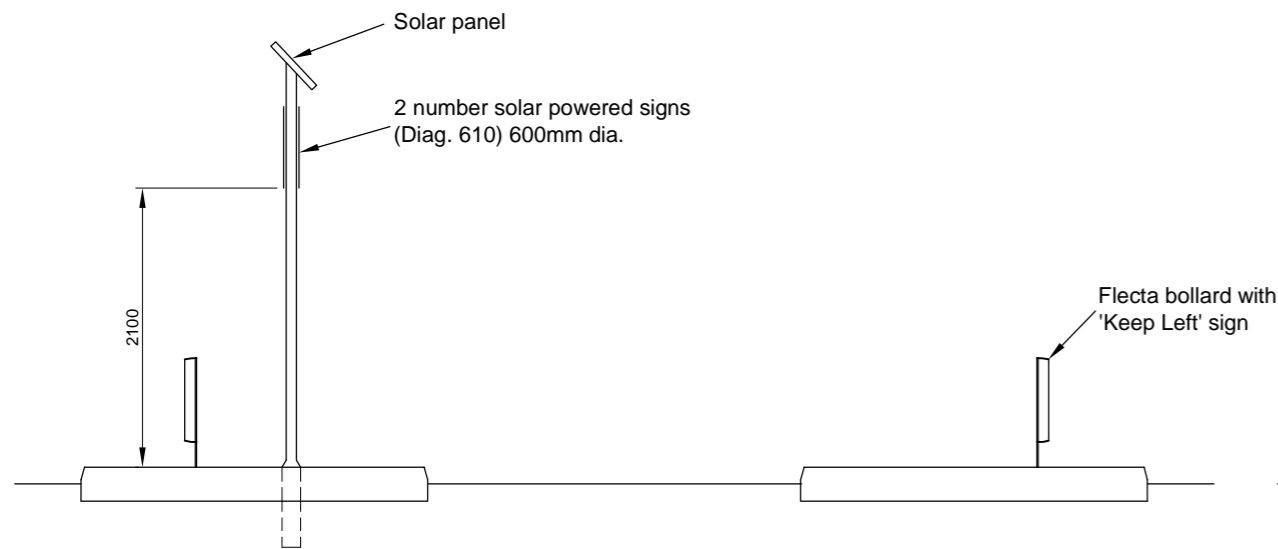

NOTES

1. All dimensions are in millimetres unless stated otherwise.
2. Refer to B 702.1 for kerbing details.
3. Dropper kerb Types DR1 and DL1 shall be cut to form a vertical joint with adjacent Type HB2 kerbs.
4. Type BN kerbs shall be laid with a maximum upstand of 6mm above carriageway.
5. Refuge islands shall be of Type 1 footway construction. Refer to B 704.1 for details.
6. Tactile blister paving shall be red at controlled crossings, otherwise buff in colour. Tactile blister paving shall comprise 400mm x 400mm x 50mm precast concrete paving bedded on 25mm moist sand/cement mortar (3:1), joints filled with 4:1 mix to within 2mm of the paving surface. Paving shall be Type A as defined in Fig. 2 of the 'Guidance on the Use of Tactile Paving Surfaces' Department of Transport.
7. Alternative proposals to the pole mounting system shown on this detail shall be approved in advance by the Overseeing Organisation.
8. For details on Flecta bollards see drawing K 703.5
9. Pedestrian refuges narrower than 2000mm shall only be provided in locations where the full 2000mm cannot be achieved.

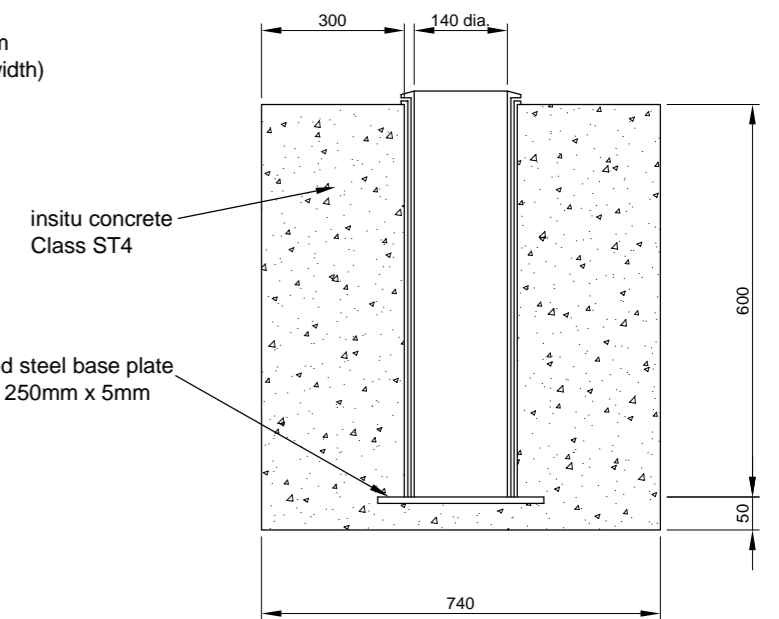
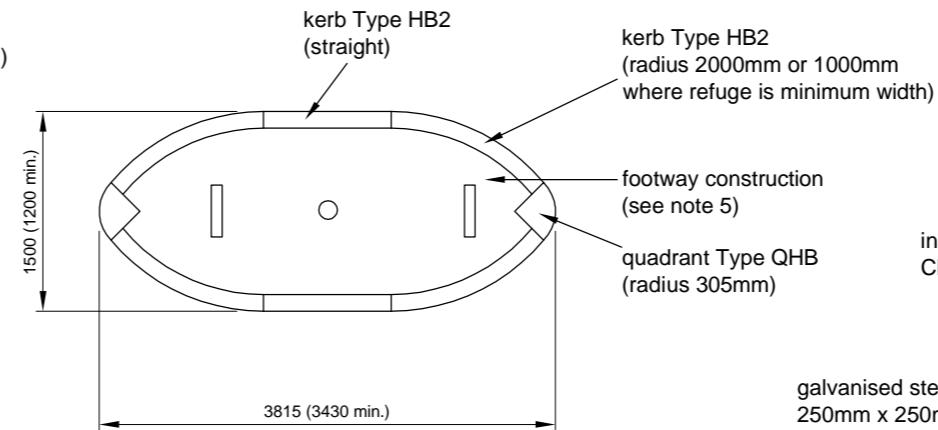
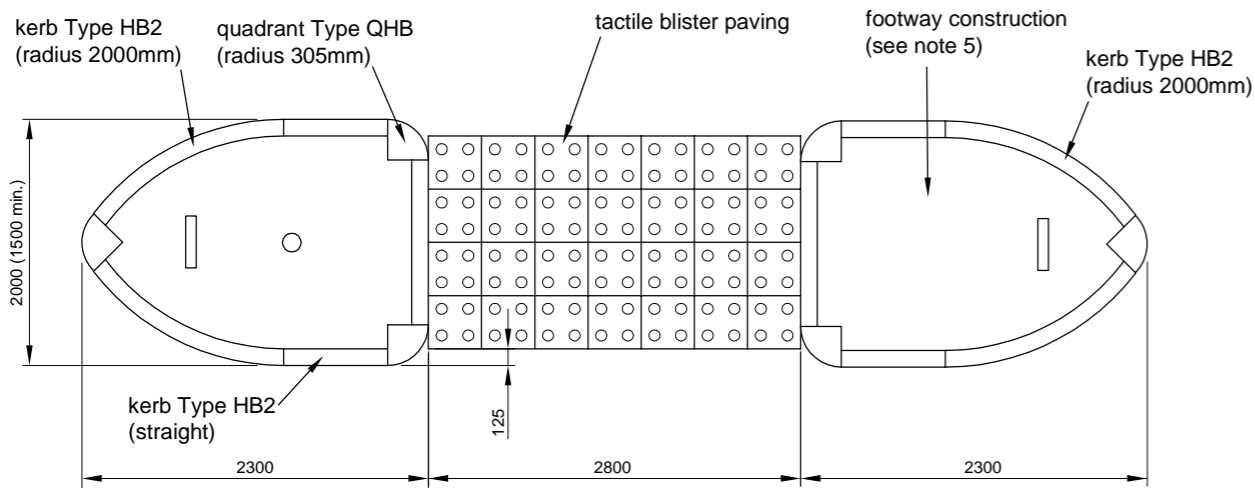

REFUGE WITH FLEXIBLE SIGNAGE AND SOLAR POWERED SIGN

POLE MOUNTING SYSTEM

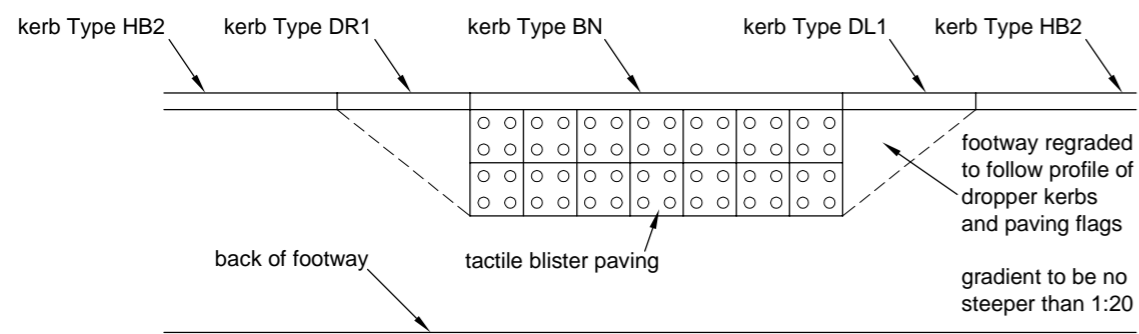

PEDESTRIAN REFUGE WITH FLEXIBLE SIGNAGE AND SOLAR POWERED SIGNS

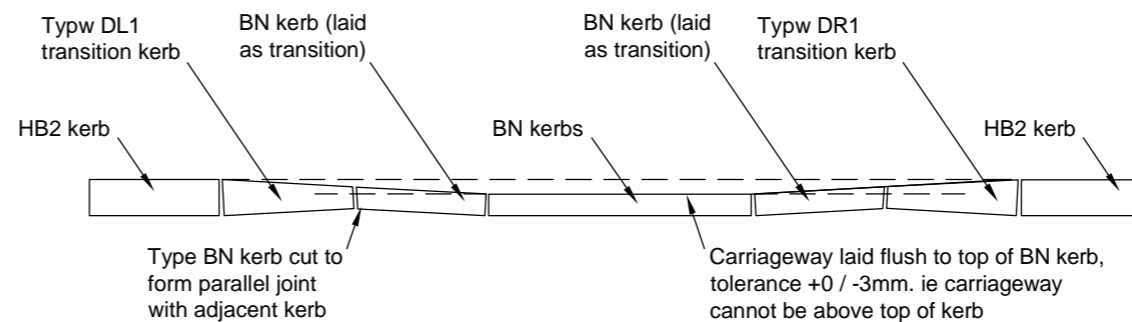

KERB DETAILS TO ACHIEVE GRADIENT OF 1:11 OR FLATTER



HIGHWAY CONSTRUCTION DETAILS

TITLE 1 MISCELLANEOUS

TITLE 2 REFUGE AND PEDESTRIAN REFUGE WITH FLEXIBLE SIGNAGE AND SOLAR POWERED SIGN

| PREVIOUS ISSUES | | ALL DIMENSIONS IN MILLIMETRES UNLESS STATED OTHERWISE | ORIGINAL DRAWING SIZE 420mm x 297mm | |
|-----------------|----------|---|-------------------------------------|---------------------|
| ISSUE | DATE | | DRN | RJB |
| 1 | FEB 2005 | NOT TO SCALE | | CHKD CS |
| 2 | MAY 2010 | DRG NO. | K 703.3 | ISSUE STATUS 3 |
| | | | | ISSUE DATE OCT 2010 |

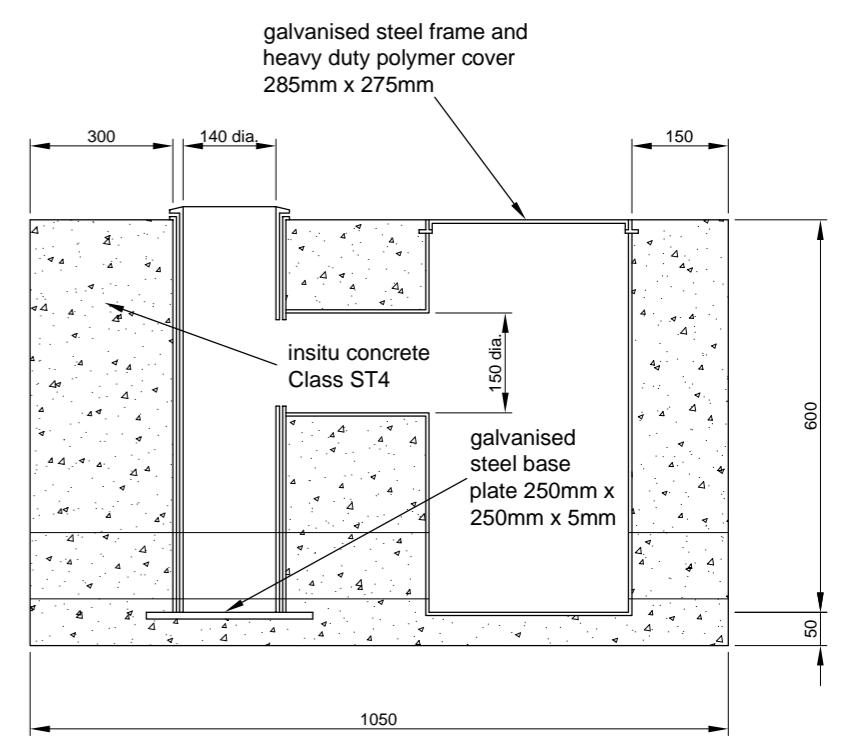
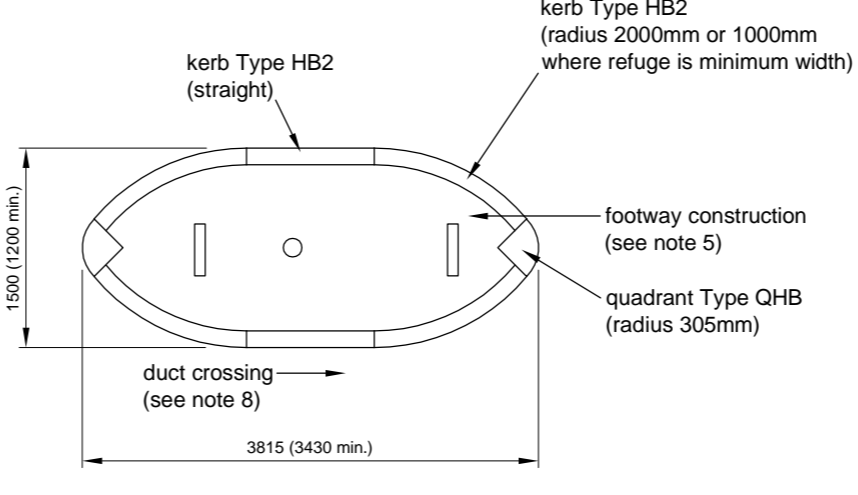
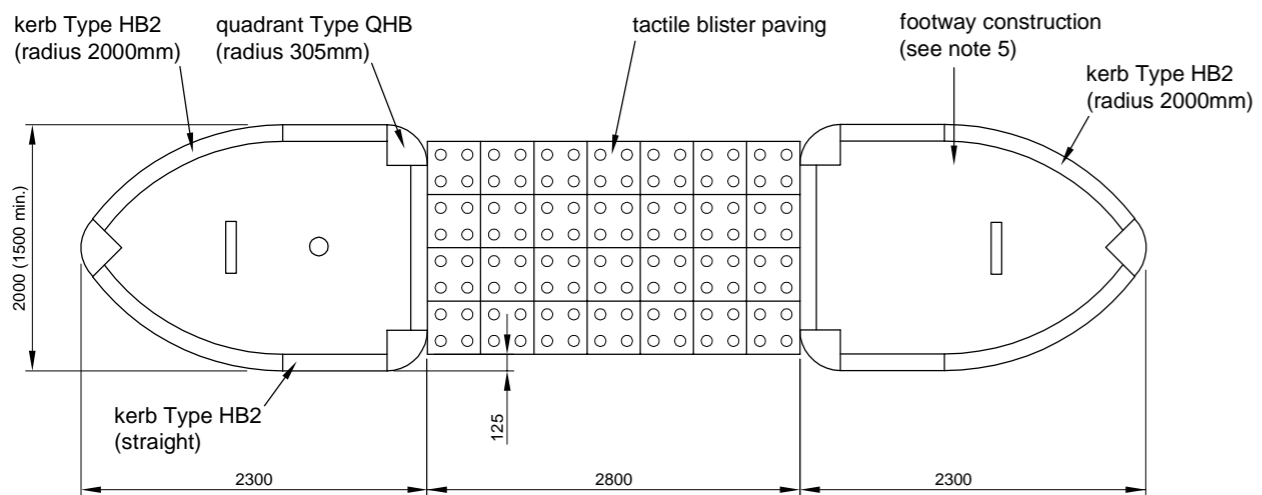
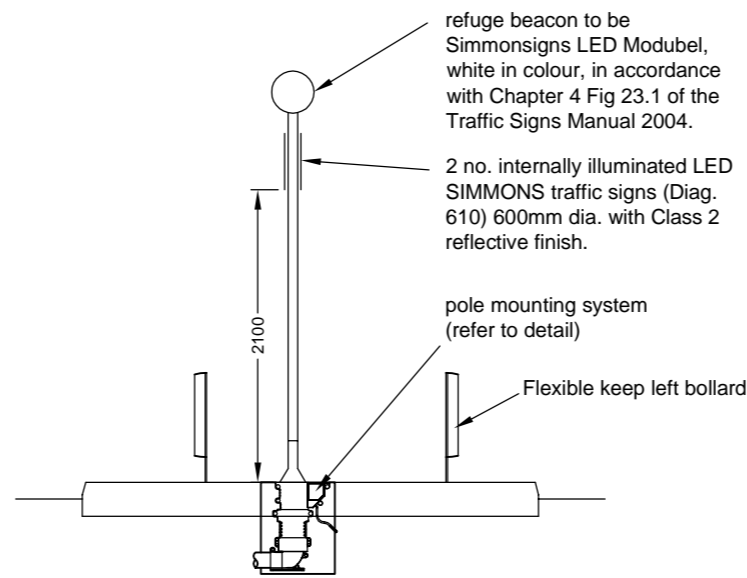
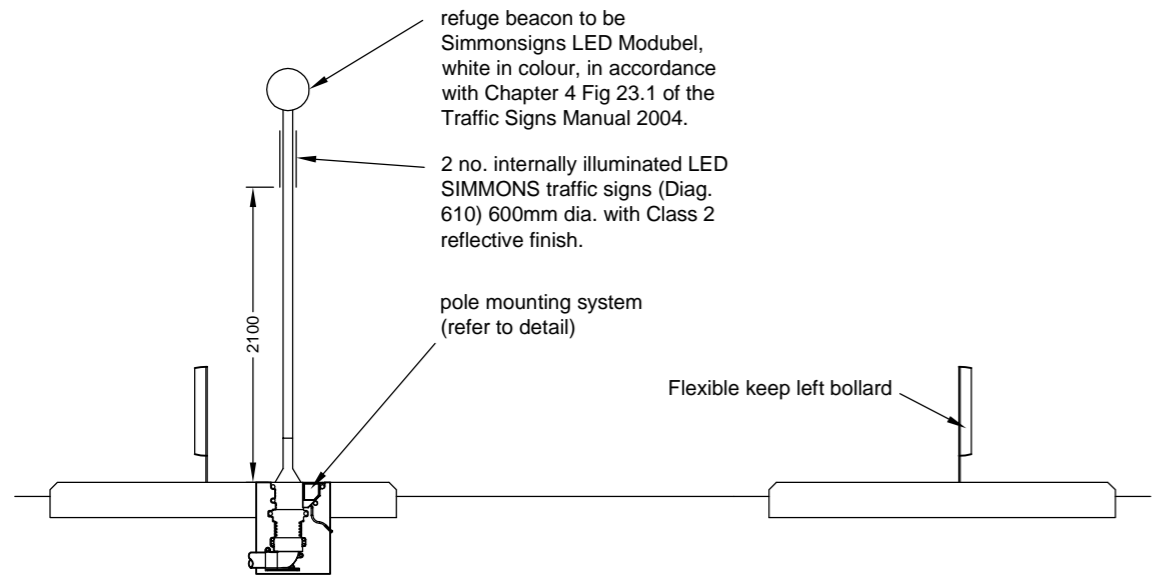

NOTES

1. All dimensions are in millimetres unless stated otherwise.
2. Refer to B 702.1 for kerbing details.
3. Dropper kerb Types DR1 and DL1 shall be cut to form a vertical joint with adjacent Type HB2 kerbs.
4. Type BN kerbs shall be laid with a maximum upstand of 6mm above carriageway.
5. Refuge islands shall be of Type 1 footway construction. Refer to B 704.1 for details.
6. Tactile blister paving shall be red at controlled crossings, otherwise buff in colour. Tactile blister paving shall comprise 400mm x 400mm x 50mm precast concrete paving bedded on 25mm moist sand/cement mortar (3:1), joints filled with 4:1 mix to within 2mm of the paving surface. Paving shall be Type A as defined in Fig. 2 of the 'Guidance on the Use of Tactile Paving Surfaces' Department of Transport.
7. Alternative proposals to the pole mounting system shown on this detail shall be approved in advance by the Overseeing Organisation.
8. Duct crossing shall comprise 1 No. 100mm internal diameter high density polyethylene, smooth single wall orange service duct, across carriageway in concrete surround with drawcord (minimum cover 600mm). Refer to I 701.1, Notes for Guidance Annex 1 and Appendix 5/2 for duct group details.
9. For details on Flecta bollards see drawing K 703.5
10. Pedestrian refuges narrower than 2000mm shall only be provided in locations where the full 2000mm cannot be achieved.

REFUGE WITH FLEXIBLE SIGNAGE AND BEACON

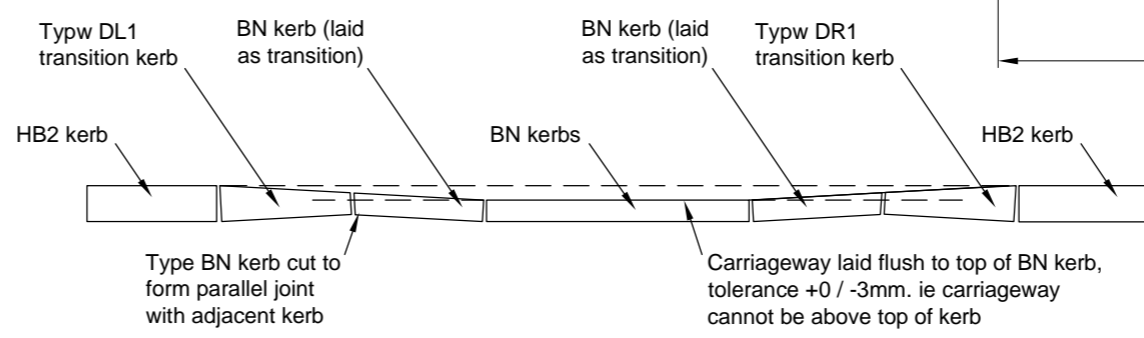

KERB DETAILS TO ACHIEVE GRADIENT OF 1:11 OR FLATTER

PEDESTRIAN REFUGE WITH FLEXIBLE SIGNAGE AND BEACON

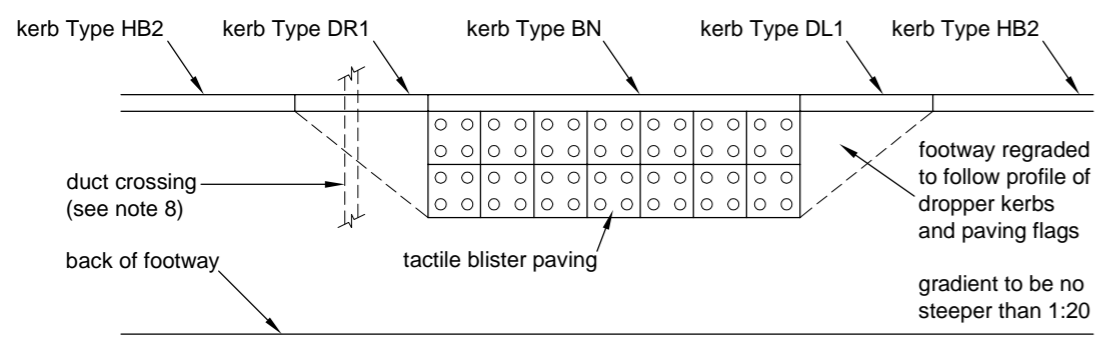

HIGHWAY CONSTRUCTION DETAILS

| | |
|---------|---------------|
| TITLE 1 | MISCELLANEOUS |
|---------|---------------|

| | |
|---------|---|
| TITLE 2 | REFUGE AND PEDESTRIAN REFUGE WITH FLEXIBLE SIGNAGE AND BEACON |
|---------|---|

| | | | | |
|-----------------|---|-------------------------------------|---------|--------------|
| PREVIOUS ISSUES | ALL DIMENSIONS IN MILLIMETRES UNLESS STATED OTHERWISE | ORIGINAL DRAWING SIZE 420mm x 297mm | | |
| ISSUE | DATE | NOT TO SCALE | DRN | RJB |
| 1 | FEB 2005 | | | CHKD |
| 2 | MAY 2010 | | | CS |
| | | DRG NO. | K 703.4 | ISSUE STATUS |
| | | | | 3 |
| | | | | ISSUE DATE |
| | | | | OCT 2010 |

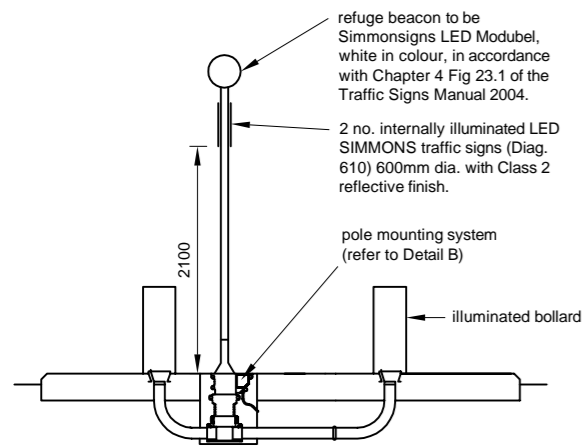

**TYPE 2 REFUGE (STANDARD)
WITH BEACON AND ILLUMINATED BOLLARD**

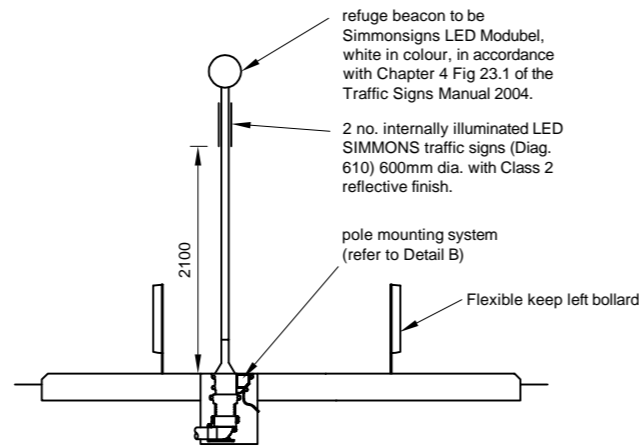

**TYPE 2 REFUGE (STANDARD)
WITH BEACON AND FLEXIBLE SIGNAGE**

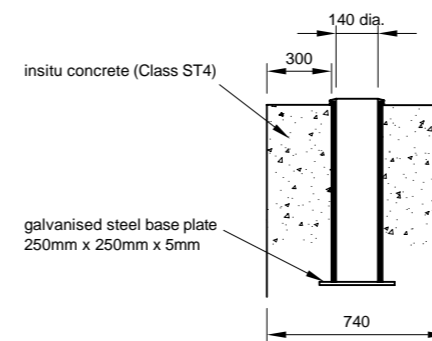

**DETAIL A: POLE MOUNTING SYSTEM
DETAIL FOR SOLAR PANEL POST**

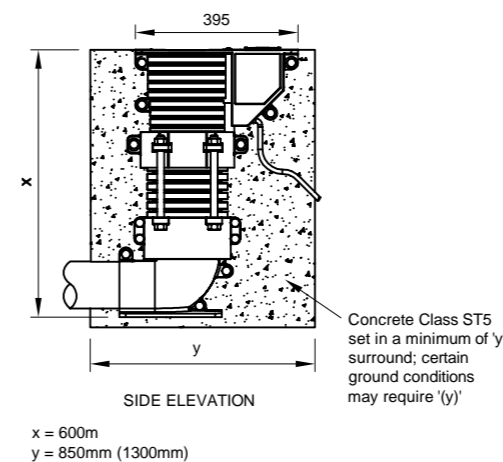
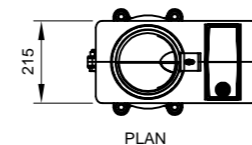

**DETAIL B: RS140 RETENTION SOCKET
SYSTEM WITH DUCKFOOT BEND OR
EQUIVALENT TYPE APPROVED**

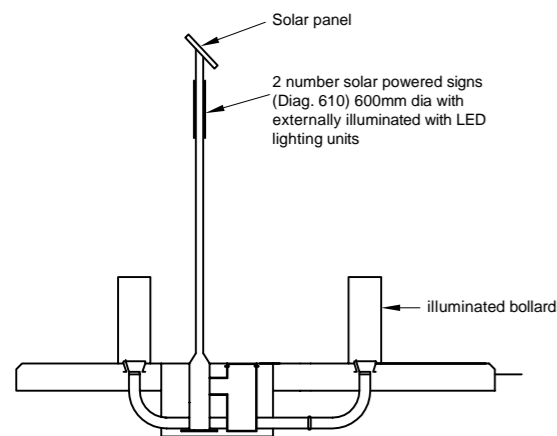

**TYPE 2 REFUGE (STANDARD) WITH SOLAR
POWERED SIGN AND ILLUMINATED BOLLARD**

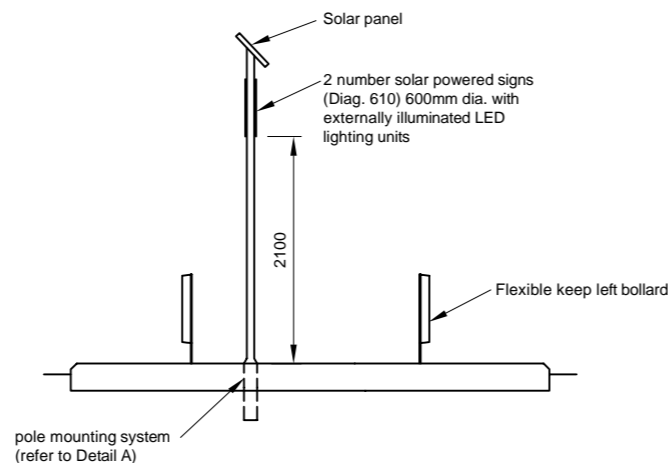

**TYPE 2 REFUGE (STANDARD) WITH SOLAR
POWERED SIGN AND FLEXIBLE SIGNAGE**

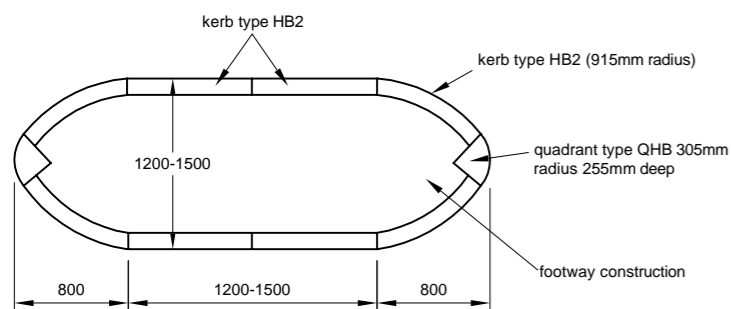

**TYPE 2 REFUGE (STANDARD)
WITH BEACON AND
ILLUMINATED BOLLARD**

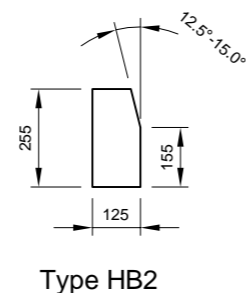

KERB DETAILS

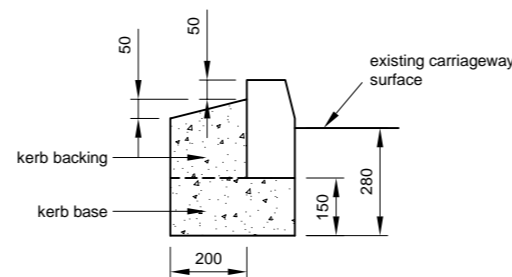

KERB BASE & BACKING DETAILS

NOTES

1. All dimensions are in millimetres unless stated otherwise.
2. The kerb base and backing material shall be Class ST2 concrete.
3. All vertical faces on the kerb base and backing shall be formed with shuttering.
4. Kerbs shall be backed up while the kerb base remains plastic (max. 6hrs after batching).
5. For kerblines radii not exceeding 12 metres, appropriate curved kerbs shall be used.
6. Footway construction shall be in accordance with the Footway/Cycleway Construction shown on B704.1.
7. Refer to I701.1 and K701.1 for duct and trench reinstatement details.
8. Refer to drawing K703.7 for Illuminated Bollard detail
9. Refer to drawing K703.6 for solar and unlit Flecta Bollard details

| | | | | |
|------------------------|------|---|-------------------------------------|---------|
| PREVIOUS ISSUES | | ALL DIMENSIONS IN MILLIMETRES UNLESS STATED OTHERWISE | ORIGINAL DRAWING SIZE 420mm x 297mm | |
| ISSUE | DATE | | DRN | RJB |
| | | NOT TO SCALE | | CHKD CS |
| DRG NO. K 703.5 | | ISSUE STATUS 1 | ISSUE DATE MAY 2010 | |

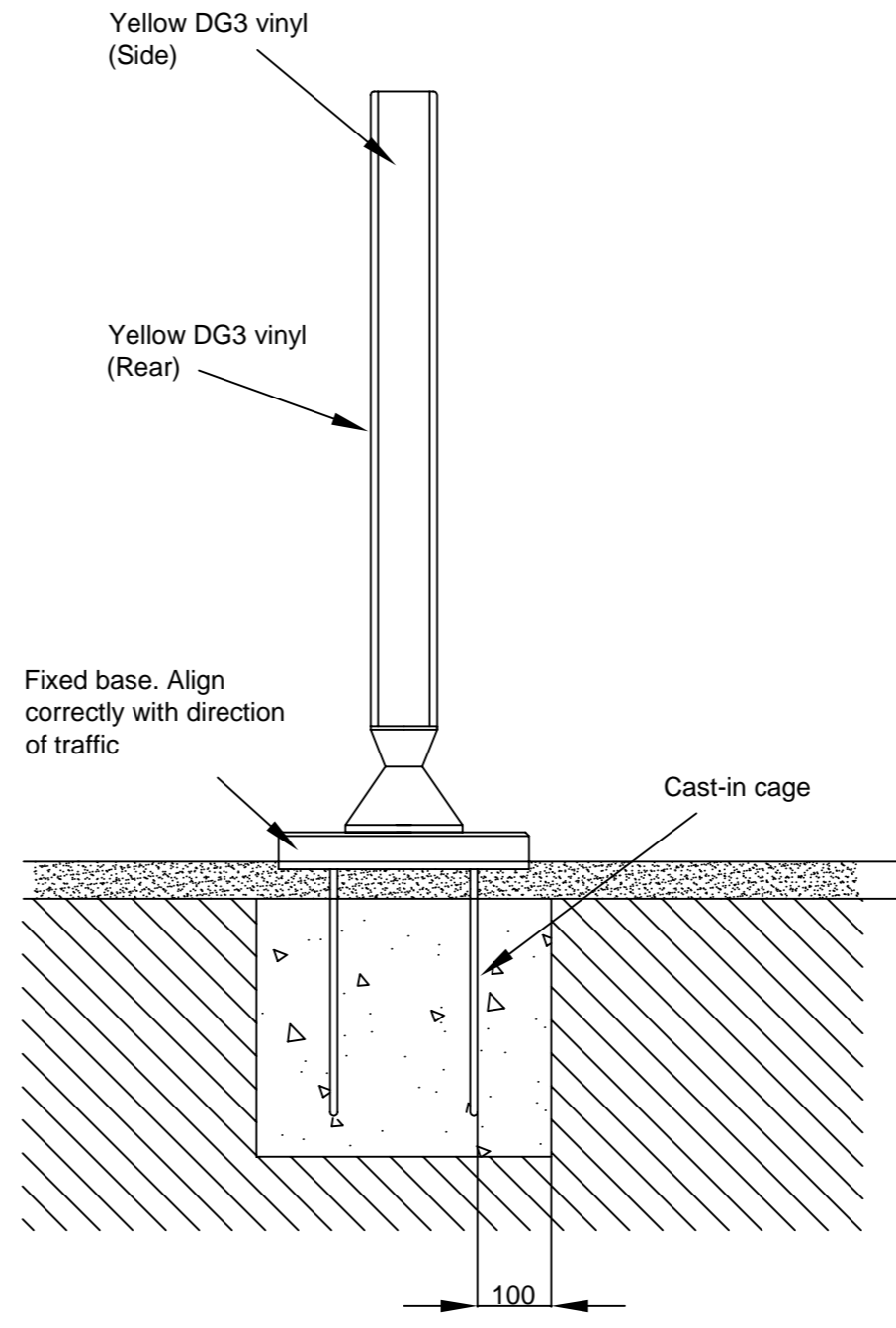
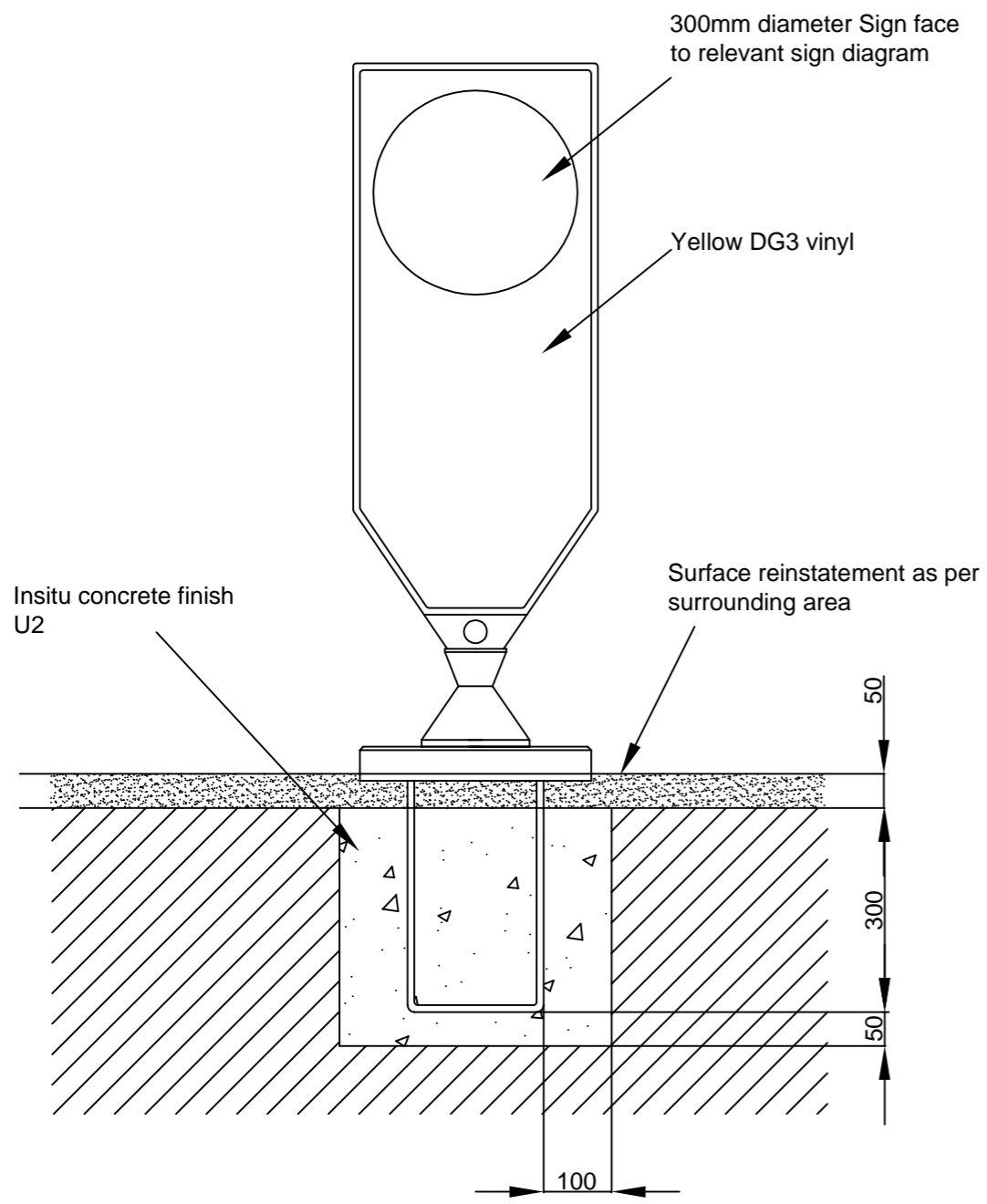

NOTES

- 1 All dimensions are in millimetres unless specified.
- 2 Illuminated type bollards to have intergrated solar panel mounted on top surface of bollard.
- 3 All bollards to conform to BS EN 12767.
- 4 All bollards to have front rear and side DG3 vinyl in flourescent yellow 4081 to BS8408:2005.
- 5 All bollards to have 6 year delamination gaurentee.
- 6 All bollards to have anti-fly/anti-graffiti film.
- 7 Body to be formed in black Polypropylene.
- 8 Illuminated bollard to be lit by integral LED.
- 9 Type of bollard to be discussed and agreed with Warwickshire County Council Street Lighting section prior to installation. See guidance below

Examples of locations which require illuminated type -
 i) Refuges where no other equipment is installed.
 ii) Splitter islands at roundabouts (Not plain face type).

Examples of locations which can be unilluminated type -
 i) Refuges with traffic signals poles installed.
 ii) Refuges where there is a refuge beacon installed and a lit keep left arrow (diag 610) is attached to the beacon post.
 iii) All plain face type bollards.

APPROVED SUPPLIERS

Traffic Management Products Ltd
 Woodbridge House
 Chapel Road
 Smallfield
 Surrey
 RH6 9NW
 United Kingdom
 Tel +44 (0) 1342 844437
 Fax +44 (0) 1342 844438
 Email info@traffic-products.co.uk

Glasdon UK Limited
 Preston New Road
 Blackpool
 Lancashire
 FY4 4UL
 United Kingdom
 Tel +44 (0) 1253 600410
 Fax +44 (0) 1253 792558
 Email sales@glasdon-uk.co.uk



HIGHWAY
 CONSTRUCTION
 DETAILS

TITLE 1
 MISCELLANEOUS

TITLE 2
 SOLAR AND UNLIT BOLLARDS

| PREVIOUS ISSUES | | ALL DIMENSIONS IN MILLIMETRES UNLESS STATED OTHERWISE | ORIGINAL DRAWING SIZE 420mm x 297mm | |
|-----------------|------|---|-------------------------------------|---------------------|
| ISSUE | DATE | | DRN | RJB |
| | | NOT TO SCALE | | CHKD CS |
| | | DRG NO. K 703.6 | ISSUE STATUS 1 | ISSUE DATE MAY 2010 |

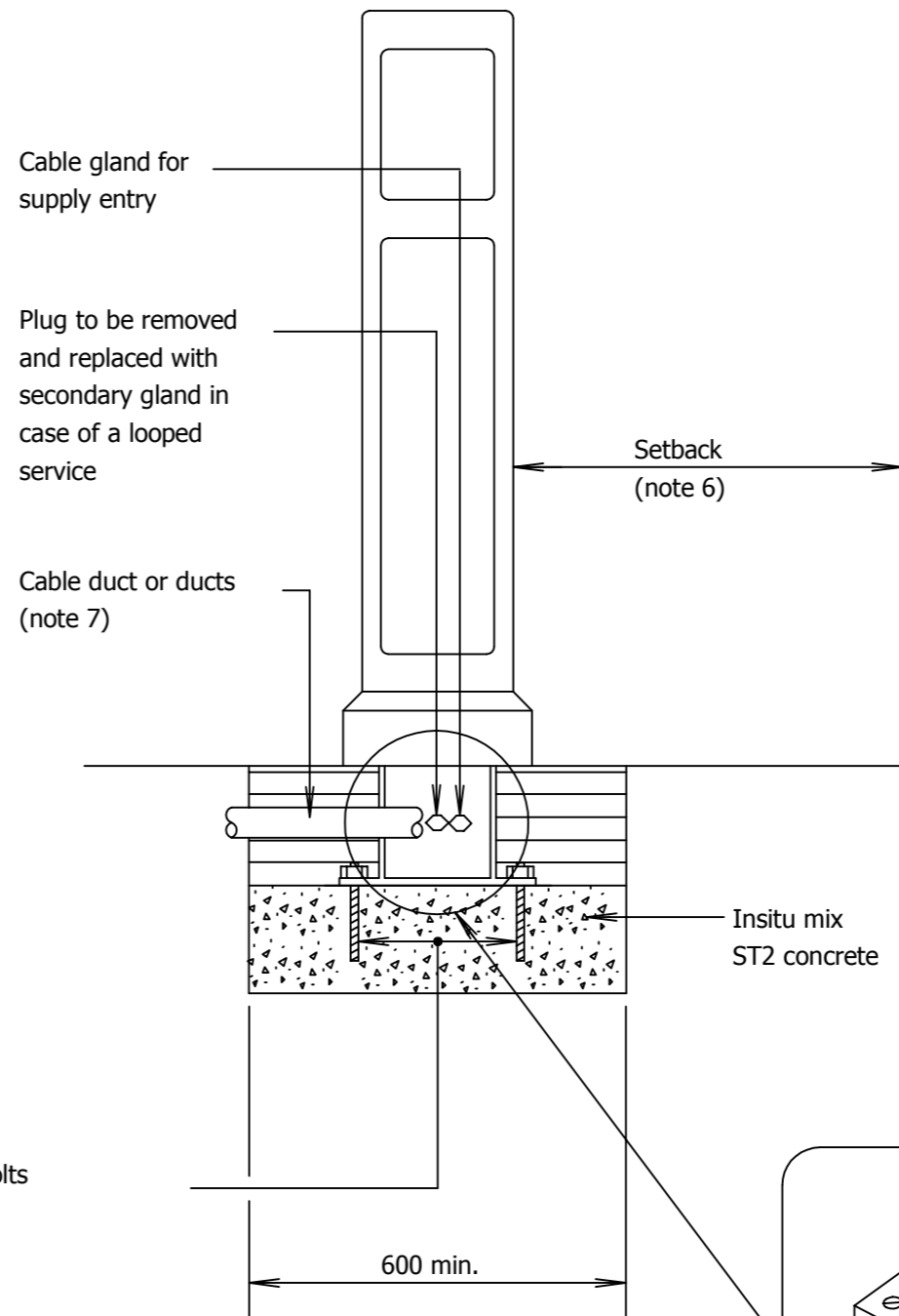
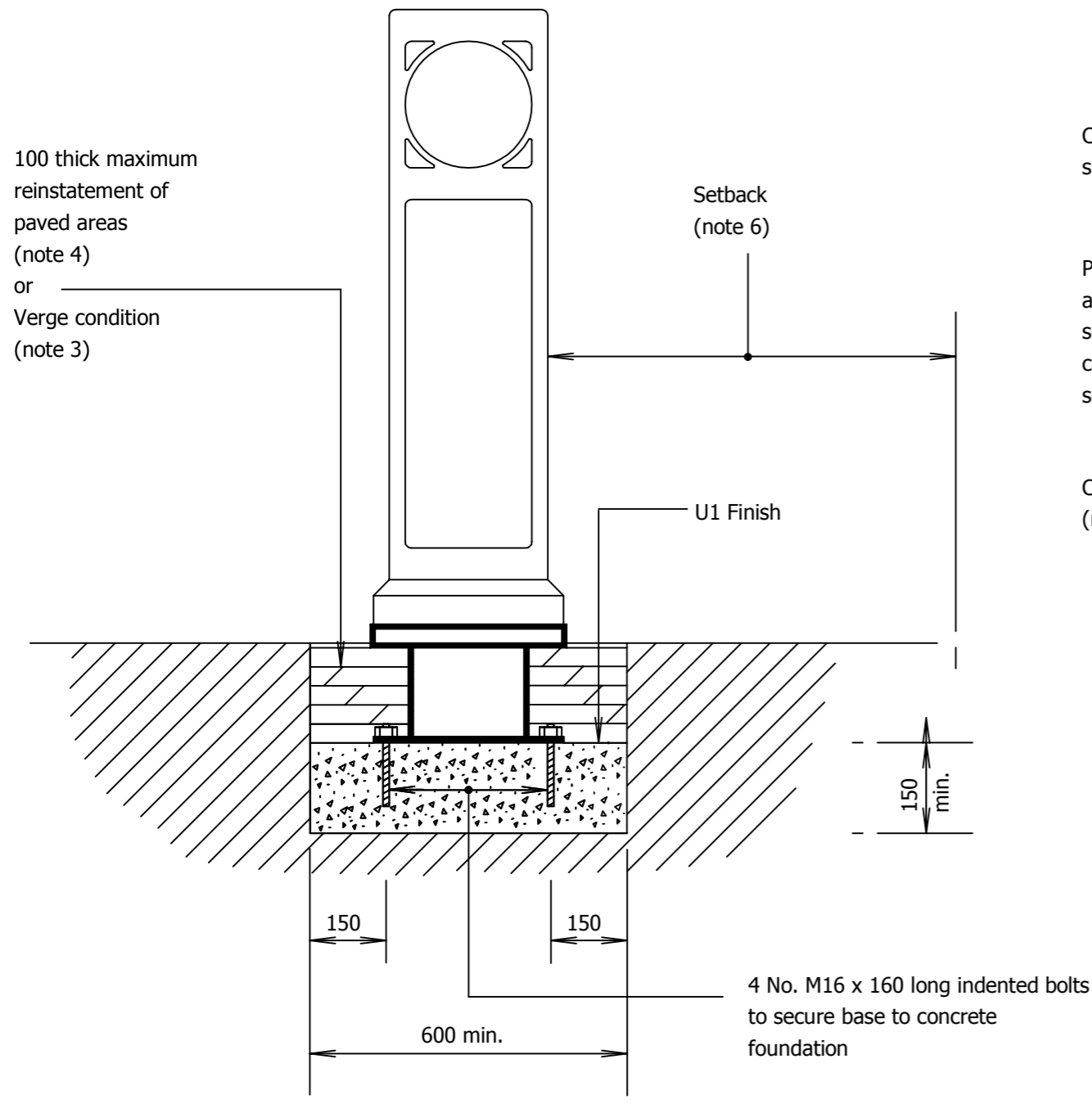

- NOTES**
- 1 ALL DIMENSIONS ARE IN MILLIMETRES
 - 2 Bollard shell type and details are specified in Appendix 12/1.
 - 3 Insitu concrete to be continued to ground level in verge condition, Finish U2.
 - 4 Reinstatement of footways and paved areas are described in Appendix 7/2.
 - 5 Identification markings are to be a 65mm high black number on a yellow background fixed to the rear of the shell
 - 6 A minimum setback of 500 is required from bollard face to traffic face of kerb in all directions.
 - 7 Cable duct or ducts to terminate as close to the cable entry point as is practicable. Exposed cable to be laid on a sand bed and surround.
 - 8 Shells to be bolted to base light

APPROVED SUPPLIERS

BASE LIGHT
 Simonsigns
 Global LED Base light

BOLLARD SHELL
 Simonsigns
 270mm - Symbol
 600mm - Contourt

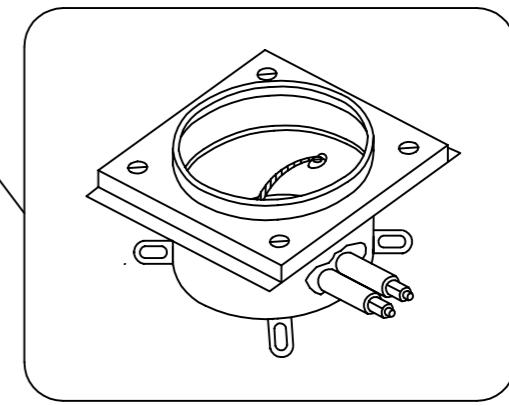

| PREVIOUS ISSUES | | ALL DIMENSIONS IN MILLIMETRES UNLESS STATED OTHERWISE | ORIGINAL DRAWING SIZE 420mm x 297mm | |
|-----------------|------|---|-------------------------------------|----------------------------|
| ISSUE | DATE | | DRN | CHKD |
| | | NOT TO SCALE | RJB | CS |
| | | DRG NO. K 703.7 | ISSUE STATUS 1 | ISSUE DATE MAY 2010 |

MOUNTING OF LARGER SIGNS

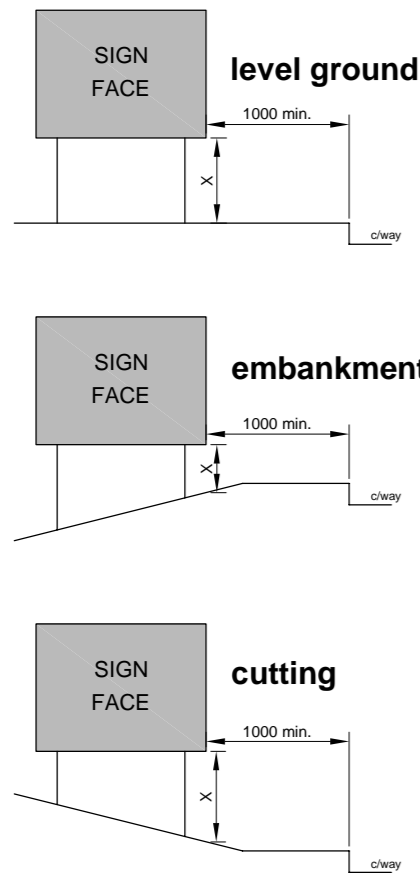

MOUNTING OF SMALLER SIGNS

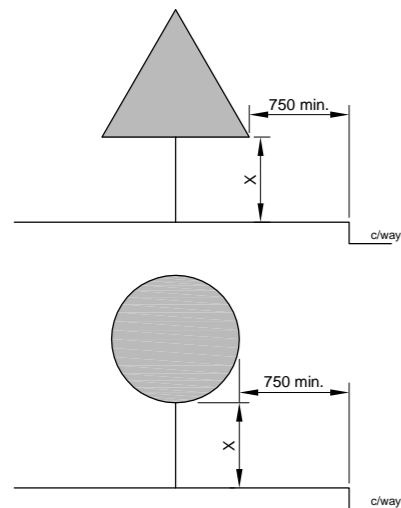

POST AND FOOTING DETAIL

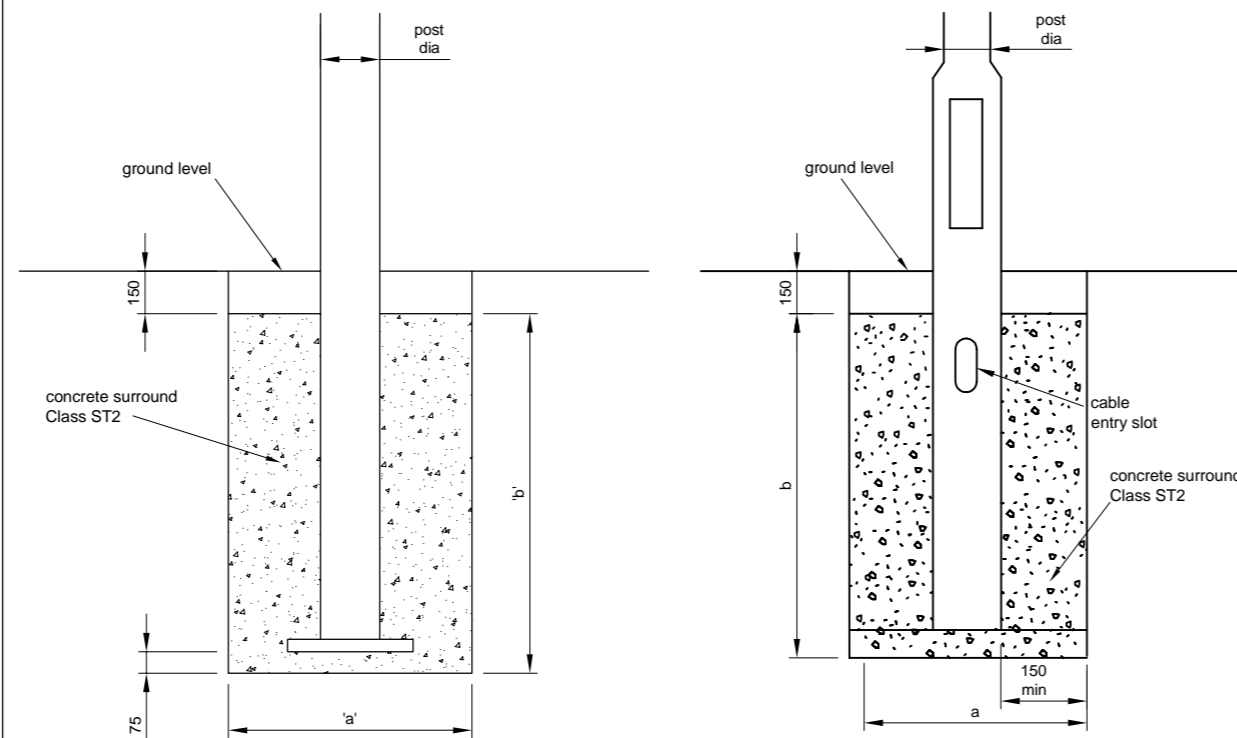

BASE DETAIL FOR TUBULAR STEEL POST

BASE DETAIL FOR TUBULAR STEEL POST WITH WIDE BASE FOR LIGHTING CONNECTION

Base dimensions 'a' & 'b' as specified.
Surface to be reinstated to match surrounding ground (dimension 'a' may be circular or square).

PLANTING DEPTH AND BASE DETAILS

| Post dia | Dimension 'a' | Dimension 'b' | |
|----------|---------------|---------------|------------|
| 76 | 350 | 525 | small base |
| 76 | 1000 | 700 | large base |
| 89 | 1200 | 700 | |
| 114 | 1400 | 900 | |

Blanking or cover plates
16 swg aluminium for either steel or aluminium substrates

NOTES

- All dimensions are in millimetres unless stated otherwise.
- Dimension 'X' represents the sign mounting height.
- Signs shall be manufactured to: the current parts of BS EN 12899:2007 and BS EN 12899-1:2007, 'The Traffic Signs Regulations and General Directions', and 'The Traffic Signs Manual'.
- Sign faces shall be manufactured from 3.0mm thick sheet aluminium unless stated otherwise.
- Stiffening or framing shall be off aluminium angle or channel to BS 873 : Part 6, 1983.
- All signs shall be single sided unless scheduled otherwise.
- Stiffening or framing shall be of aluminium angle or channel to BS EN 12899-1: 2007.
- Non-reflective signs shall be screen printed onto a suitable non-reflective material approved in advance by the Overseeing Organisation.
- Reflective signs Class 1 and 2 shall be as defined in BS EN 12899-1: 2007.
- Internally illuminated bollards shall be of a suitable type approved in advance by the Overseeing Organisation.
- Externally lit signs to be Simmonsigns LUA LED type or LUB Mk-T 2 x 11w PLL.
- All external lighting units shall be fitted with photo-electric control of a type approved in advance by the Overseeing Organisation except units on 'Keep Left' (Diag. 610) and 'Turn Left' (Diag. 609) signs, which must be continuously energised.
- External lighting units that are to be in accordance with the Traffic Signs Manual: Chapter 11, Appendix VI, Table 1 shall be approved in advance by the Overseeing Organisation and fitted with power factor correction to not less than 0.85 LAG.
- All necessary stub posts, conduits and fixings shall be supplied.
- Where required, cover or blanking plates shall be fixed with 5mm dia. stainless steel bolts, washers and nuts, with a 5mm thick by 12mm dia. plastic distance piece between the sign face and plate.
- Door opening 425 x 100 minimum. (Lit signs only)
- Hole to be formed in concrete to line up with cable entry slot of column. (Lit signs only)
- Except where otherwise stated in Appendix 13/1 doors to base compartment shall face away from oncoming traffic. (Lit signs only)
- Identification markings are to be a 65mm high black number on a yellow background fixed to the post below the sign plate. (Lit signs only)
- Post and Footing Notes:
Planting depth, outside diameter of post, and footing dimensions 'a' and 'b' shall be as specified on the traffic signs schedule. Dimension 'a' may be either circular or square.
The void above the upper surface of the footing shall be backfilled or reinstated to match existing conditions.
The surface finish for posts shall be as listed in Appendix 19/3.
Aluminium posts may be used as an alternative to tubular steel posts where the sign is to be unlit and the specified OD of the post is 76mm or 114mm. Where used, aluminium posts shall be anodised AA/25 to BS EN 12373-1: 2001 and dyed grey.
On the traffic sign schedule: 'T' = tubular steel, 'R' = rectangular steel, and 'A' = aluminium.
- Where a post diameter of 76 mm is specified, the 'small base' is required for signs not exceeding 0.25 sq m in area and the 'large base' for signs exceeding 0.25 sq m in area.



HIGHWAY CONSTRUCTION DETAILS

TITLE 1

MISCELLANEOUS

TITLE 2

TRAFFIC SIGNS: FABRICATION & MOUNTING DETAILS

| PREVIOUS ISSUES | | ALL DIMENSIONS IN MILLIMETRES UNLESS STATED OTHERWISE | ORIGINAL DRAWING SIZE 420mm x 297mm | | |
|-----------------|----------|---|-------------------------------------|---------------------|----|
| ISSUE | DATE | | | CHKD | CS |
| 1 | FEB 2005 | NOT TO SCALE | DRN | RJB | |
| | | DRG NO. K 704.1 | ISSUE STATUS 2 | ISSUE DATE MAY 2010 | |

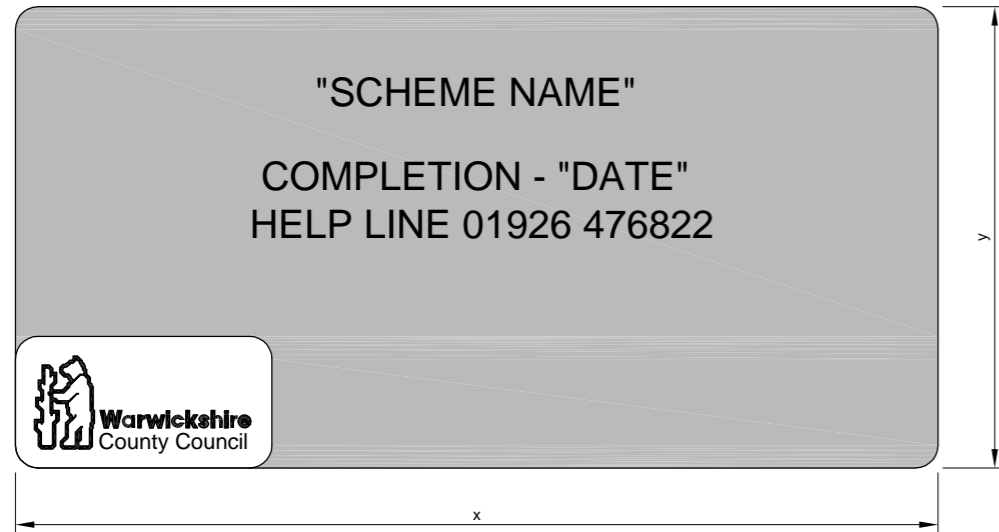

SIGN BOARD TYPE 1A

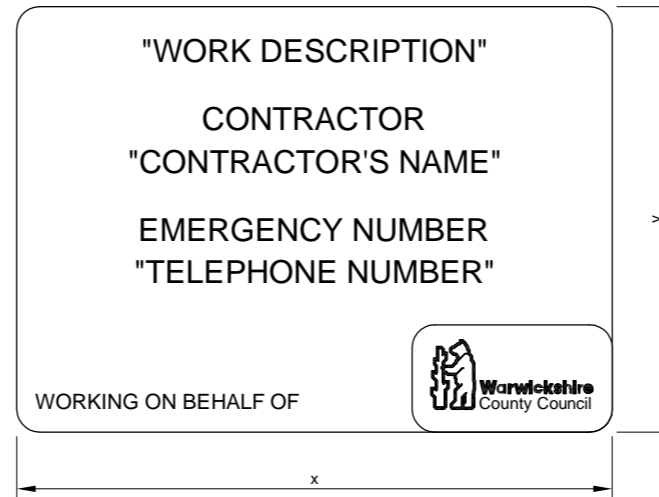

SIGN BOARD TYPE 2

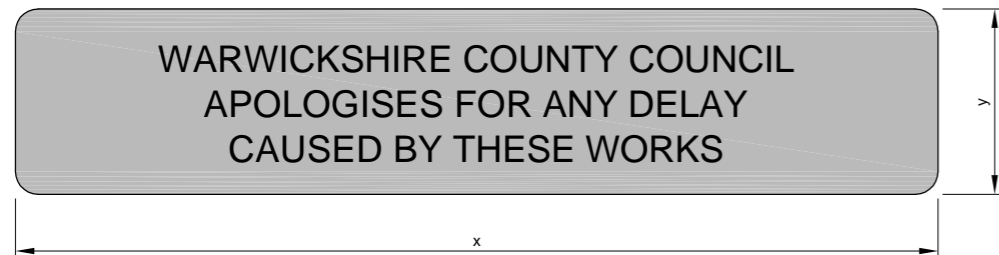

SIGN BOARD TYPE 1B

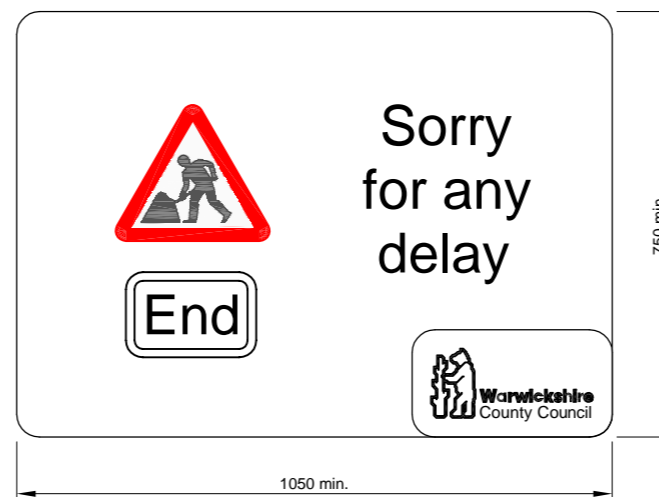

SIGN BOARD TYPE 4

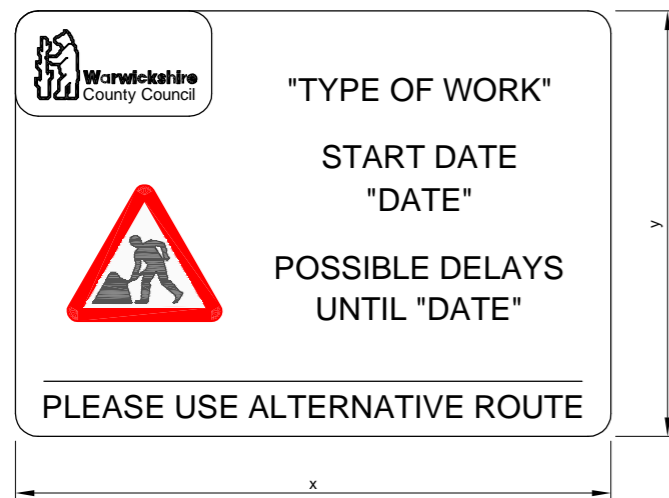

SIGN BOARD TYPE 3

| SIGN BOARD SIZES | | | |
|---|--------------------------|-------------------------|--------------------------|
| SPEED LIMIT ON ROAD WHERE SIGN IS TO BE ERECTED | SIGN 1A | SIGN 1B | SIGNS 2 & 3 |
| 30 mph | x = 1580mm y = 1130mm | x = 1580mm y = 320mm | x = 1580mm y = 1130mm |
| 40 mph and over | x = 2440mm y = 1220mm | x = 2440mm y = 490mm | x = 1980mm y = 1410mm |

NOTES

- All dimensions are in millimetres unless stated otherwise.
- Sign board faces shall be manufactured from a material approved in advance by the Overseeing Organisation. Corners shall be rounded off at 40mm radius.
- The size of the Warwickshire County Council and Design Services logos, shall be such that they match approximately, the proportions of the sign faces shown on this detail.
- The layout of sign board Type 4 shall be broadly in accordance with the Traffic Signs Regulations and General Directions Diag. 7006.
- The height of the triangular warning sign (Diag. 7001) on sign board Type 4 shall be 600mm.
- Colour and picture image for the triangular warning sign (Diag. 7001) and 'End' lettering on sign board Type 4 shall be in accordance with the Traffic Signs Regulations and General Directions.
- The Warwickshire County Council logos shall be green in colour to BS 5252F-14 E 56. The logo background shall be white in colour to BS 5252F-00 E 55.
- Colour, text style, text size, and picture image details for the Warwickshire County Council logo will be supplied by the Overseeing Organisation upon request.
- The text style for lettering other than that which forms part of a logo shall be Arial.
- The background to sign board Types 1A, 1B, 3 and 4 shall be yellow in colour to BS 5252F-10 E 55.
- The background to sign board Type 2 shall be red in colour to BS 5252F-04 E 53
- Lettering other than that which forms part of a logo on sign board Types 1A, 1B, 3 and 4 shall be black in colour to BS 5252F-00 E 53.
- Lettering other than that which forms part of a logo on sign board Type 2 shall be white in colour to BS 5252F-00 E 55.
- 'X' height for lettering is as defined in Chapter 7 of The Traffic Signs Manual.
- The 'X' height for 'End' lettering on sign board Type 4 shall be 80mm. The 'X' height for other lettering on this sign board shall be 100mm.
- Sign Type 1A or 1A/1B combined shall be mounted at a height of 1.0m where visibility criteria can be satisfied and where no footway exists. All other boards shall be mounted at a height of 2.1m. Boards shall be mounted on 2 no. 114mm dia. posts planted at a depth of 750mm. Footing dimensions 'a' and 'b' shall be 400mm and 675mm respectively. All posts shall be manufactured in steel and be supplied with end caps, base plates and all other necessary fittings. Refer to K 704.1 for sign mounting and footing details.
- Where sign board Type 3 is not specified and sign board Type 1A/1B is to be erected on the nearside verge facing oncoming traffic; sign board Type 4 may be erected on the reverse side of sign board 1A/1B.
- 'Type of Work' text on sign board Type 3 shall be approved in advance by the Overseeing Organisation.
- Descriptions or dates which may change over the course of the construction period, shall be displayed in lettering which can be removed and replaced without damaging the remainder of the sign board.

| SIGN TEXT HEIGHT (SIGNS 1A & 1B) | |
|---|-------------------------|
| SPEED LIMIT ON ROAD WHERE SIGN IS TO BE ERECTED | 'X' HEIGHT OF TEXT (mm) |
| 30 mph | TO FIT |
| 40 mph and over | 60 |

| SIGN TEXT HEIGHT (SIGNS 2 & 3) | |
|---|-------------------------|
| SPEED LIMIT ON ROAD WHERE SIGN IS TO BE ERECTED | 'X' HEIGHT OF TEXT (mm) |
| 30 mph | 60 |
| 40 mph and over | 75 |



HIGHWAY CONSTRUCTION DETAILS

TITLE 1

MISCELLANEOUS

TITLE 2

SIGN BOARD DETAILS: TYPES 1, 2, 3 & 4

| PREVIOUS ISSUES | | ALL DIMENSIONS IN MILLIMETRES UNLESS STATED OTHERWISE | ORIGINAL DRAWING SIZE 420mm x 297mm | |
|-----------------|----------|---|-------------------------------------|---------------------|
| ISSUE | DATE | | DRN | CHKD |
| 1 | FEB 2005 | NOT TO SCALE | RJB | CS |
| | | DRG NO. K 705.1 | ISSUE STATUS 2 | ISSUE DATE MAY 2010 |

HOW DID WE DO?

CALL

01926 476822



NOTES

1. All dimensions are in millimetres unless stated otherwise.
2. Sign board faces shall be manufactured from a material approved in advance by the Overseeing Organisation. Corners shall be rounded off at 40mm radius.
3. The size of the Warwickshire County Council logo, shall be such that it matches approximately, the proportion of the sign face shown on this detail.
4. The Warwickshire County Council logo shall be green in colour to BS 5252F-14 E 56. The logo background shall be white in colour to BS 5252F-00 E 55.
5. Text style, text size, and picture image details for the Warwickshire County Council logo will be supplied by the Overseeing Organisation upon request.
6. The text style for lettering other than that which forms part of the logo shall be Arial.
7. The background to the sign board shall be yellow in colour to BS 5252F-10 E 55. The background shall be framed with a 20mm wide border, green in colour to BS 5252F-14 E 56.
8. Lettering other than that which forms part of the Warwickshire County Council logo shall be black in colour to BS 5252F-00 E 53.
9. 'X' height for lettering is as defined in Chapter 7 of The Traffic Signs Manual.
10. The 'X' height for lettering other than that which forms part of the Warwickshire County Council logo shall be 75mm.
11. The sign shall be mounted at a height of 1.0m where visibility criteria can be satisfied and where no footway exists. Otherwise, the board shall be mounted at a height of 2.1m. The boards shall be mounted on 2 no. 114mm dia. posts planted at a depth of 750mm. Footing dimensions 'a' and 'b' shall be 400mm and 675mm respectively. All posts shall be manufactured in steel and be supplied with end caps, base plates and all other necessary fittings. Refer to K 704.1 for sign mounting and footing details.
12. Sign boards, including posts and footings shall be removed 3 weeks after the erection date.



HIGHWAY
CONSTRUCTION
DETAILS

TITLE 1

MISCELLANEOUS

TITLE 2

SIGN BOARD DETAILS:
TYPE 5

| PREVIOUS ISSUES | | ALL DIMENSIONS IN MILLIMETRES UNLESS STATED OTHERWISE | ORIGINAL DRAWING SIZE 420mm x 297mm | |
|-----------------|----------|---|-------------------------------------|---------------------|
| ISSUE | DATE | | DRN | CHKD |
| 1 | FEB 2005 | NOT TO SCALE | RJB | CS |
| | | DRG NO. K 705.2 | ISSUE STATUS 2 | ISSUE DATE MAY 2010 |

0mm 50mm 100mm 150mm 200mm

This plot was produced from a digital source so may not be at true scale. It is the recipient's responsibility to confirm its accuracy.

NOTES

1. All dimensions are in millimetres unless stated otherwise.
2. Controller cabinet and stool shall be of a type approved in advance by the Overseeing Organisation.
3. Epoxy resin for the layer between controller cabinet and stool shall be of a type approved in advance by the Overseeing Organisation.

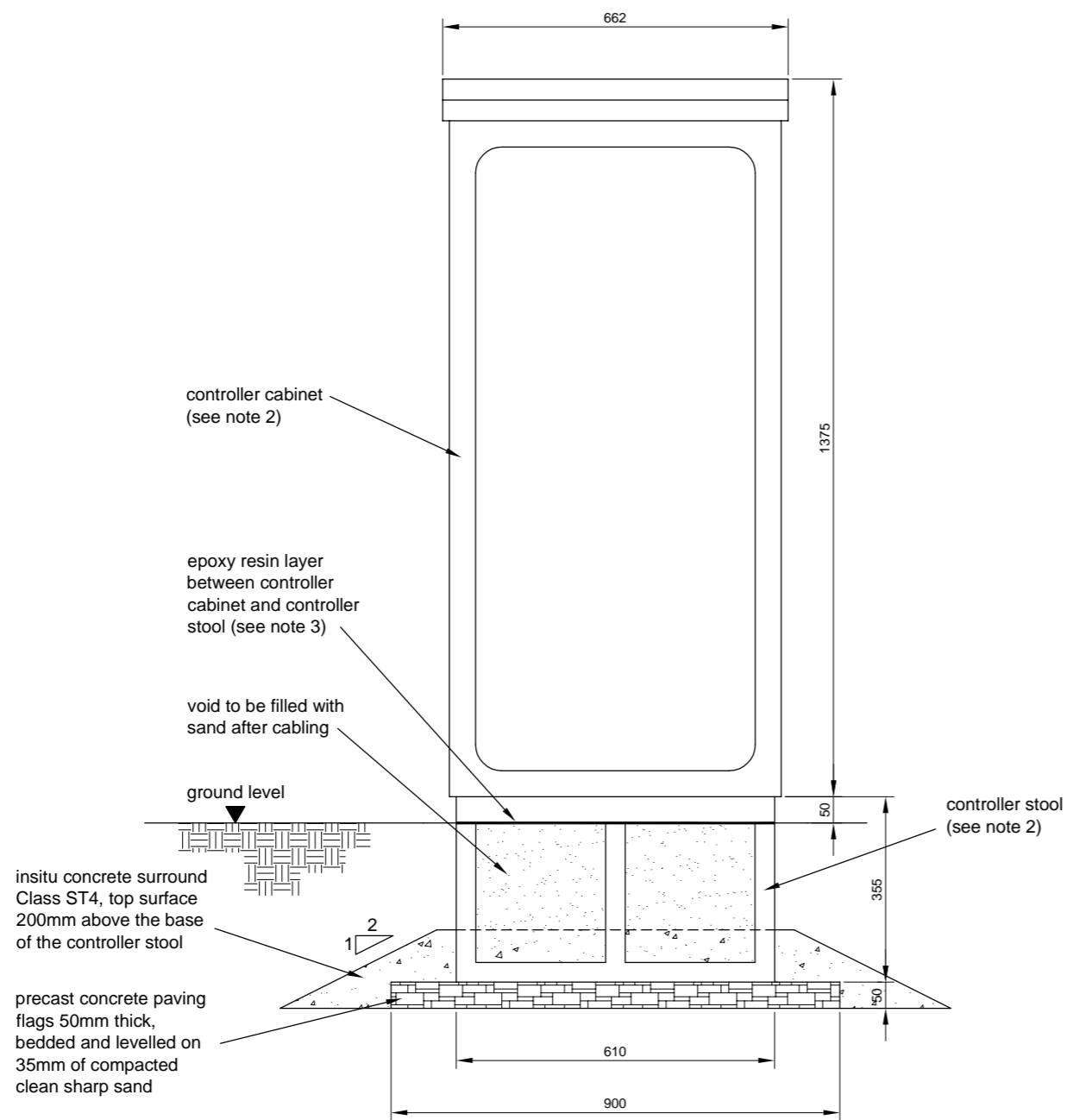

CONTROLLER CABINET DIMENSIONS AND INSTALLATION DETAILS



HIGHWAY CONSTRUCTION DETAILS

TITLE 1
MISCELLANEOUS

TITLE 2
TRAFFIC SIGNAL CONTROLLER CABINET

| PREVIOUS ISSUES | | ALL DIMENSIONS IN MILLIMETRES UNLESS STATED OTHERWISE | ORIGINAL DRAWING SIZE 420mm x 297mm | |
|-----------------|----------|---|-------------------------------------|----------------------------|
| ISSUE | DATE | | DRN | CHKD |
| 1 | FEB 2005 | NOT TO SCALE | RJB | CS |
| | | DRG NO. K 706.1 | ISSUE STATUS 2 | ISSUE DATE MAY 2010 |

0mm 50mm 100mm 150mm 200mm

This plot was produced from a digital source so may not be at true scale. It is the recipient's responsibility to confirm its accuracy.